

- NOTES**
1. BARGE AND CABLE GUIDE TO REMAIN AFTER CONSTRUCTION FOR FUTURE USE BY OWNER.
 2. EXISTING GOODWIN TUNNEL APPROXIMATELY 50 TO 100 FEET BELOW PROPOSED CANYON TUNNEL, TO BE VERIFIED.
 3. REFER TO SHEETS 5.0, 5.0.1, 5.0.2, 5.0.3 AND 5.0.4 FOR CONTROL STRUCTURE, PORTAL WALL LOCATION AND TUNNEL INLET DIMENSIONS, TO BE VERIFIED.

COPYRIGHT 2022 BY PROVOST & PRITCHARD ENGINEERING GROUP, INC. ALL RIGHTS RESERVED. The firm of Provost & Pritchard Engineering Group, Inc. expressly disclaims any liability for errors or omissions in these plans. These plans are not to be reproduced, changed, or copied in any form or manner whatsoever, nor are they to be used for any purpose other than that specifically intended by the client. The design and construction of these facilities shall be the responsibility of the client. The firm of Provost & Pritchard Engineering Group, Inc. is not responsible for any damage or injury to persons or property resulting from the use of these plans by a third party. The third party shall be responsible for obtaining all necessary permits and approvals from the appropriate authorities. The firm of Provost & Pritchard Engineering Group, Inc. is not responsible for any damage or injury to persons or property resulting from the use of these plans by a third party. The third party shall be responsible for obtaining all necessary permits and approvals from the appropriate authorities.

60% DESIGN	SWL	BY	DATE
NOT FOR CONSTRUCTION			11/04/2022

FOR REVIEW ONLY

CANYON TUNNEL PROJECT
 SOUTH SAN JOAQUIN IRRIGATION DISTRICT
 CALAVERAS COUNTY, CALIFORNIA
 UPSTREAM FACILITIES ALTERNATE 1

PROVOST & PRITCHARD
 ENGINEERS ARCHITECTS
 10681 GREENEY RD. SUITE J
 SONOMA, CALIFORNIA 95070
 595449-2700 FAX 595449-2715
<http://www.provostpritchard.com>

DESIGN ENGINEER: ANDREW KOSITSKY LICENSE NO: GE 2532	CHECKED BY: SWL
DRAFTED BY: KGM	DATE: 11/04/2022
JOB NO: 1055	
PROJECT NO: 22	
PHASE: 001	
ORIGINAL SCALE SHOWN IS ONE INCH. ADJUST SCALE FOR REDUCED OR ENLARGED PLANS.	
SHEET 2.0	
8 OF 23	

DISCLAIMER: THIS PLAN REPRESENTS FEATURES FOR ILLUSTRATION PURPOSES ONLY. IT IS NOT A LEGAL SURVEY AND IS NOT INTENDED FOR USE IN DETERMINING BOUNDARIES OR DIMENSIONS. ANY USE OF THIS PLAN FOR PURPOSES OTHER THAN LOCATION OF FEATURES IS DONE SO AT THE USER'S RISK AND WITHOUT THE CONSENT OF PROVOST & PRITCHARD. SEE CIVIL DOCUMENTS FOR LOCATION OF BOUNDARIES AND FEATURES.

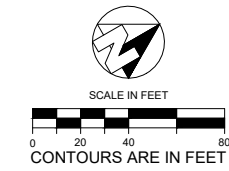
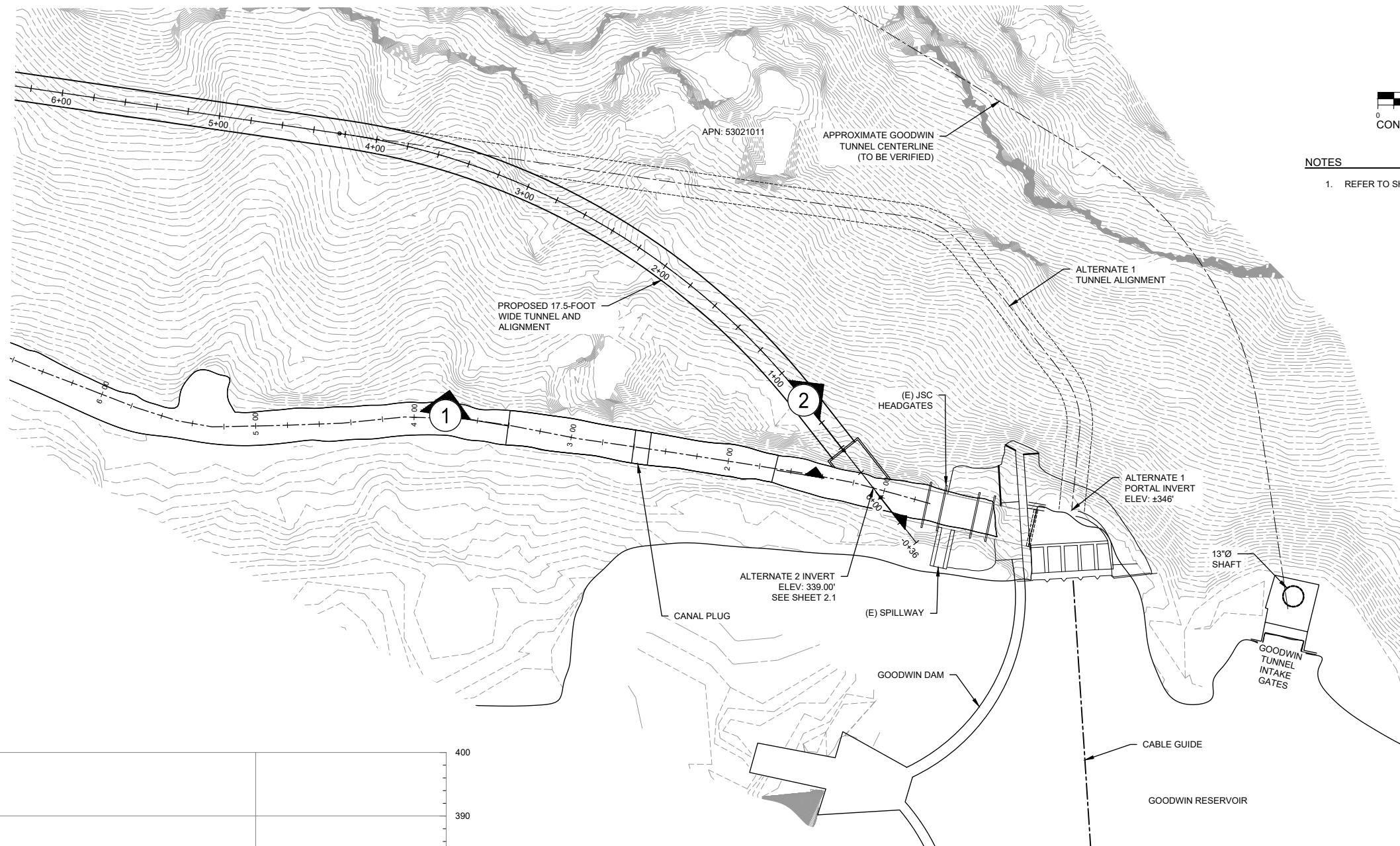

NOTES
 1. REFER TO SHEET 0.1, GENERAL NOTE 2.

COPYRIGHT 2022 BY PROVOST & PRITCHARD ENGINEERING GROUP, INC. ALL RIGHTS RESERVED. The firm of Provost & Pritchard Engineering Group, Inc. expressly disclaims any and all liability for the use of these plans, drawings or copies in any form or manner whatsoever, nor are they to be reproduced, stored in a retrieval system, transmitted, distributed, or copied in any form or manner whatsoever, nor are they to be used for any purpose other than that specifically intended by the firm of Provost & Pritchard Engineering Group, Inc. in the event of unauthorized reuse of these plans by a third party, the third party shall assume all liability for such reuse. Provost & Pritchard Engineering Group, Inc. is a registered professional engineering firm in the State of California. License No. 44512. All other rights reserved.

NO.	REVISION	BY	DATE
1	60% DESIGN	SWL	11/04/2022
60% DESIGN NOT FOR CONSTRUCTION 11/04/2022			

FOR
REVIEW
ONLY

CANYON TUNNEL PROJECT
 SOUTH SAN JOAQUIN IRRIGATION DISTRICT
 CALAVERAS COUNTY, CALIFORNIA
UPSTREAM FACILITIES ALTERNATE 2

DESIGN ENGINEER: ANDREW KOSITSKY LICENSE NO: GE 2532	
DRAFTED BY: KGM	CHECKED BY: SWL
DATE: 11/04/2022	
JOB NO: 1055	
PROJECT NO: 22	
PHASE: 001	
ORIGINAL SCALE SHOWN IS ONE INCH. ADJUST SCALE FOR REDUCED OR ENLARGED PLANS.	
SHEET 2.1	
9 OF 23	

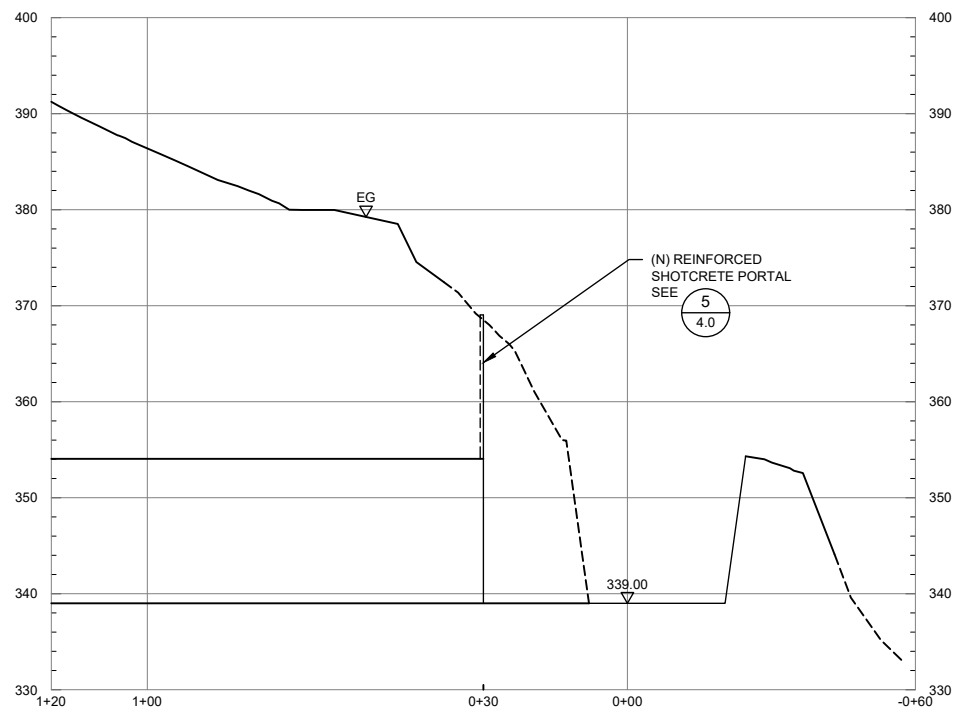

1 CANYON TUNNEL UPSTREAM PORTAL PROFILE

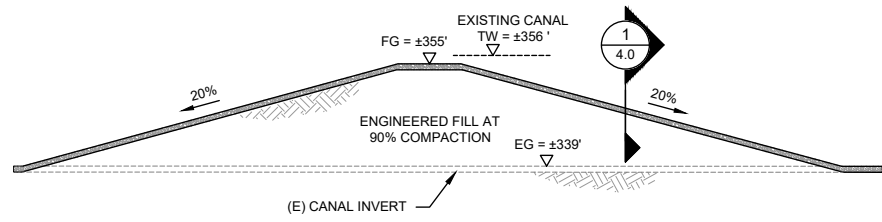
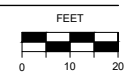

2 CANAL PLUG PROFILE

SCALE: N.T.S.

DISCLAIMER: THIS PLAN REPRESENTS FEATURES FOR ILLUSTRATION PURPOSES ONLY. IT IS NOT A LEGAL SURVEY AND IS NOT INTENDED FOR USE IN DETERMINING BOUNDARIES OR DIMENSIONS. ANY USE OF THIS PLAN FOR PURPOSES OTHER THAN LOCATION OF FEATURES IS DONE SO AT THE USER'S RISK AND WITHOUT THE CONSENT OF PROVOST & PRITCHARD. SEE CIVIL DOCUMENTS FOR LOCATION OF BOUNDARIES AND FEATURES.

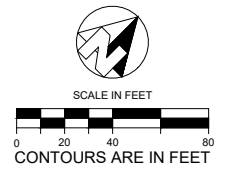
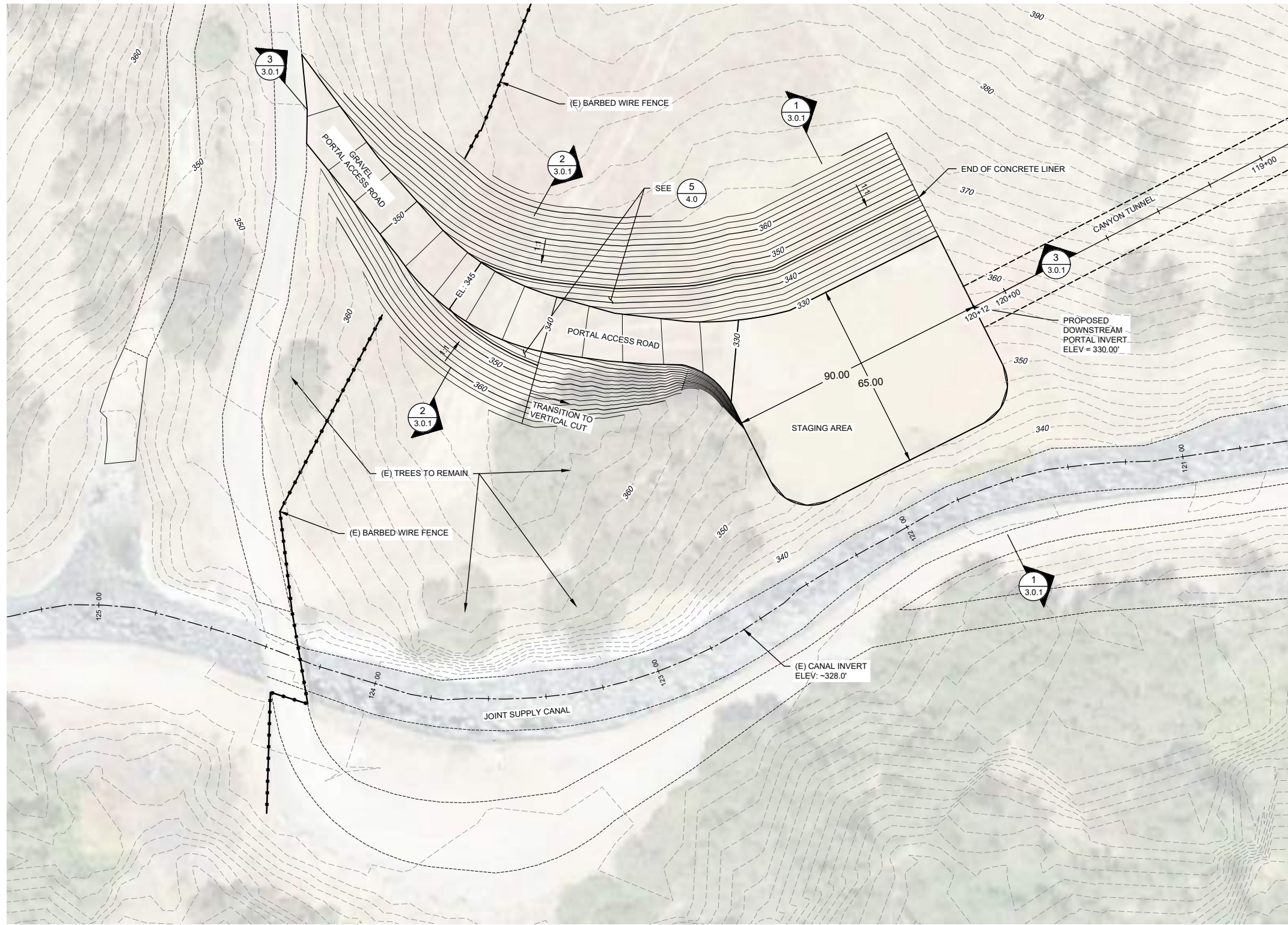

DISCLAIMER: THIS PLAN REPRESENTS FEATURES FOR ILLUSTRATION PURPOSES ONLY. IT IS NOT A LEGAL SURVEY AND IS NOT INTENDED FOR USE IN DETERMINING BOUNDARIES OR DIMENSIONS. ANY USE OF THIS PLAN FOR PURPOSES OTHER THAN LOCATION OF FEATURES IS DONE SO AT THE USER'S RISK AND WITHOUT THE CONSENT OF PROVOST & PRITCHARD. SEE CIVIL DOCUMENTS FOR LOCATION OF BOUNDARIES AND FEATURES.

COPYRIGHT 2022 BY PROVOST & PRITCHARD ENGINEERING GROUP, INC. ALL RIGHTS RESERVED. The firm of Provost & Pritchard Engineering Group, Inc. expressly disclaims any and all liability for any errors or omissions in these plans. These plans are not to be reproduced, changed, or copied in any form or manner whatsoever, nor are they to be used for any purpose other than that specifically intended. The event of unauthorized reuse of these plans by a third party, the third party shall be liable for all damages and costs of Provost & Pritchard Engineering Group, Inc. and its affiliates and shall bear the cost of Provost & Pritchard Engineering Group, Inc.'s legal fees associated with defending and enforcing these rights.

INC.	SWL	BY	DATE
▲			11/04/2022
60% DESIGN			REVISION
60% DESIGN			11/04/2022
NOT FOR CONSTRUCTION			
60% DESIGN			

FOR REVIEW ONLY

CANYON TUNNEL PROJECT
 SOUTH SAN JOAQUIN IRRIGATION DISTRICT
 CALAVERAS COUNTY, CALIFORNIA
 DOWNSTREAM PORTAL GRADING PLAN

PROVOST & PRITCHARD
 AN ENGINEERING COMPANY
 1860 GREENEY RD. SUITE J
 SONOMA, CALIFORNIA 95370
 559.494.2700 FAX 559.494.2715
<http://www.provostpritchard.com>

DESIGN ENGINEER: ANDREW KOSITSKY LICENSE NO: GE 2532	CHECKED BY: SWL
DRAFTED BY: KGM	
DATE: 11/04/2022	
JOB NO: 1055	
PROJECT NO: 22	
PHASE: 001	
ORIGINAL SCALE SHOWN IS ONE INCH. ADJUST SCALE FOR REDUCED OR ENLARGED PLANS.	
SHEET 3.0	
10 OF 23	

11/3/2022 1:57 PM G:\South San Joaquin ID-1055\105522001-Canyon Tunnel 80% Design\300 CAQ340 Sheet Ssis 02_Plan_3.0 DOWNSTREAM PORTAL GRADING PLAN.dwg -Ken McKinley

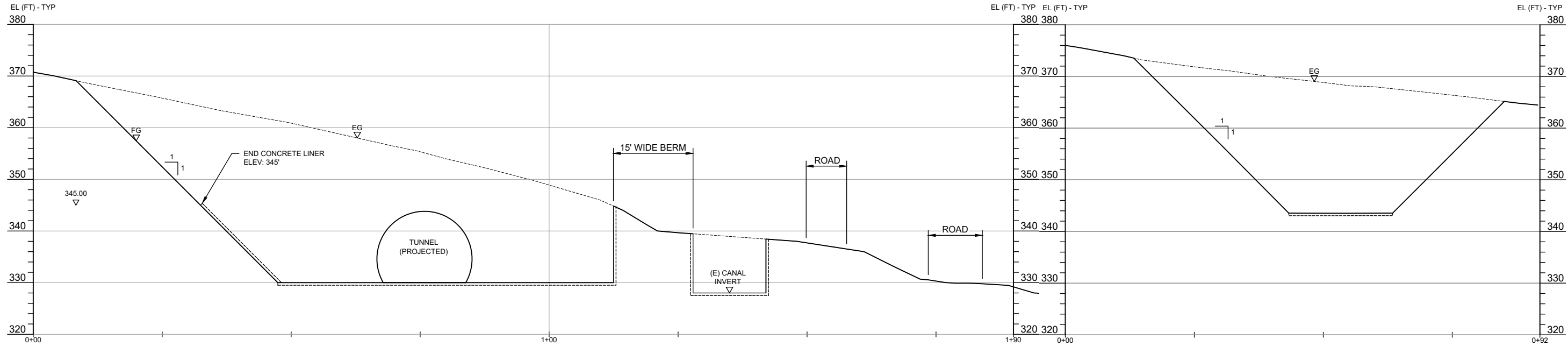

1 PORTAL STAGING CROSS SECTION/ELEVATION



2 PORTAL ACCESS ROAD CROSS SECTION

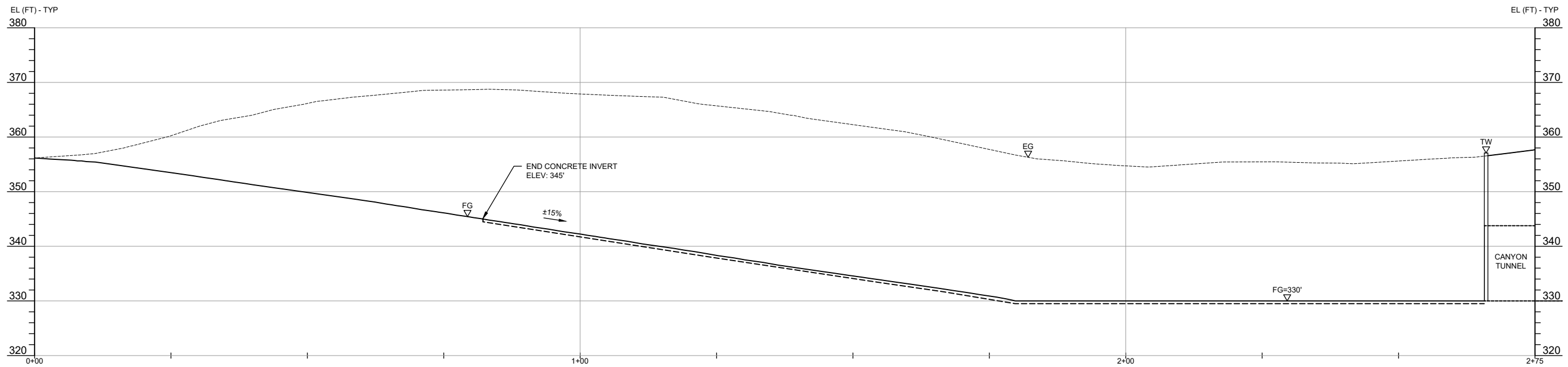
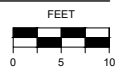

3 PORTAL ACCESS ROAD PROFILE



COPYRIGHT 2022 BY PROVOST & PRITCHARD ENGINEERING GROUP, INC. ALL RIGHTS RESERVED. The firm of Provost & Pritchard Engineering Group, Inc. expressly warrants that the design and construction of the project shall conform to the applicable laws, codes, regulations, and standards of practice in the state of California. No part of these plans may be reproduced, stored in a retrieval system, or transmitted in any form or by any means, electronic, mechanical, photocopying, recording, or by any information storage and retrieval system, without the prior written consent of Provost & Pritchard Engineering Group, Inc. In the event of unauthorized reuse of these plans by a third party, the third party shall be liable for all damages and shall bear the cost of Provost & Pritchard Engineering Group, Inc.'s legal fees associated with defending and enforcing these rights.

60% DESIGN	BY	DATE
NOT FOR CONSTRUCTION		11/04/2022
REVISION		

FOR REVIEW ONLY

CANYON TUNNEL PROJECT
 SOUTH SAN JOAQUIN IRRIGATION DISTRICT
 CALAVERAS COUNTY, CALIFORNIA

DOWNSTREAM PORTAL PROFILE

DESIGN ENGINEER: ANDREW KOSITSKY LICENSE NO: GE 2532	
DRAFTED BY:	CHECKED BY:
KGM	SWL
DATE: 11/04/2022	
JOB NO: 1055	
PROJECT NO: 22	
PHASE: 001	
ORIGINAL SCALE SHOWN IS ONE INCH. ADJUST SCALE FOR REDUCED OR ENLARGED PLANS.	
SHEET 3.0.1	
11 OF 23	

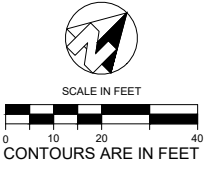

NOTES

1. TEMPORARY FACILITIES TO BE REMOVED AND RESTORED TO PRE-CONSTRUCTION CONDITIONS.

COPYRIGHT 2022 BY PROVOST & PRITCHARD ENGINEERING GROUP, INC. ALL RIGHTS RESERVED. The firm of Provost & Pritchard Engineering Group, Inc. expressly disclaims any and all liability for the use of these plans in any form or manner whatsoever, nor are they to be reproduced, stored in a retrieval system, or transmitted in any form or by any means, electronic, mechanical, photocopying, recording, or by any information storage and retrieval system, without the prior written permission and consent of Provost & Pritchard Engineering Group, Inc. In the event of unauthorized reuse of these plans by a third party, the third party shall be liable for all damages, including reasonable attorneys' fees, incurred by Provost & Pritchard Engineering Group, Inc. and its affiliates and shall bear the cost of Provost & Pritchard Engineering Group, Inc.'s legal fees associated with defending and enforcing these rights.

INC.	SWL	BY	DATE
60% DESIGN			11/04/2022
60% DESIGN NOT FOR CONSTRUCTION 11/04/2022			
REVISION			

FOR REVIEW ONLY

CANYON TUNNEL PROJECT
SOUTH SAN JOAQUIN IRRIGATION DISTRICT
CALAVERAS COUNTY, CALIFORNIA
DOWNSTREAM TEMPORARY SPOILS STOCKPILE PLAN

DESIGN ENGINEER: ANDREW KOSITSKY LICENSE NO: GE 2532	CHECKED BY: SWL
DRAFTED BY: KGM	DATE: 11/04/2022
JOB NO: 1055	
PROJECT NO: 22	
PHASE: 001	
ORIGINAL SCALE SHOWN IS ONE INCH. ADJUST SCALE FOR REDUCED OR ENLARGED PLANS.	

DISCLAIMER: THIS PLAN REPRESENTS FEATURES FOR ILLUSTRATION PURPOSES ONLY. IT IS NOT A LEGAL SURVEY AND IS NOT INTENDED FOR USE IN DETERMINING BOUNDARIES OR DIMENSIONS. ANY USE OF THIS PLAN FOR PURPOSES OTHER THAN LOCATION OF FEATURES IS DONE SO AT THE USER'S RISK AND WITHOUT THE CONSENT OF PROVOST & PRITCHARD. SEE CIVIL DOCUMENTS FOR LOCATION OF BOUNDARIES AND FEATURES.

11/3/2022 1:58 PM G:\South San Joaquin ID-1055\105522001-Canyon Tunnel 60% Design\300 CAD\340 Sheet Ssis 02_Plan_Maps\3.0.2 DOWNSTREAM TEMPORARY SPOILS STOCKPILE PLAN.dwg Kern McKinley

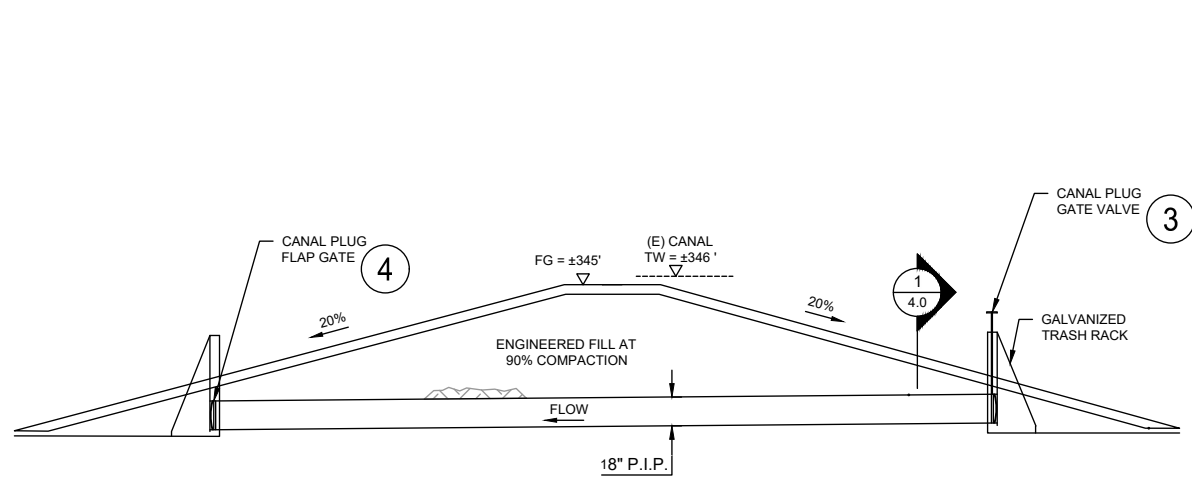
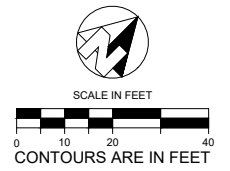
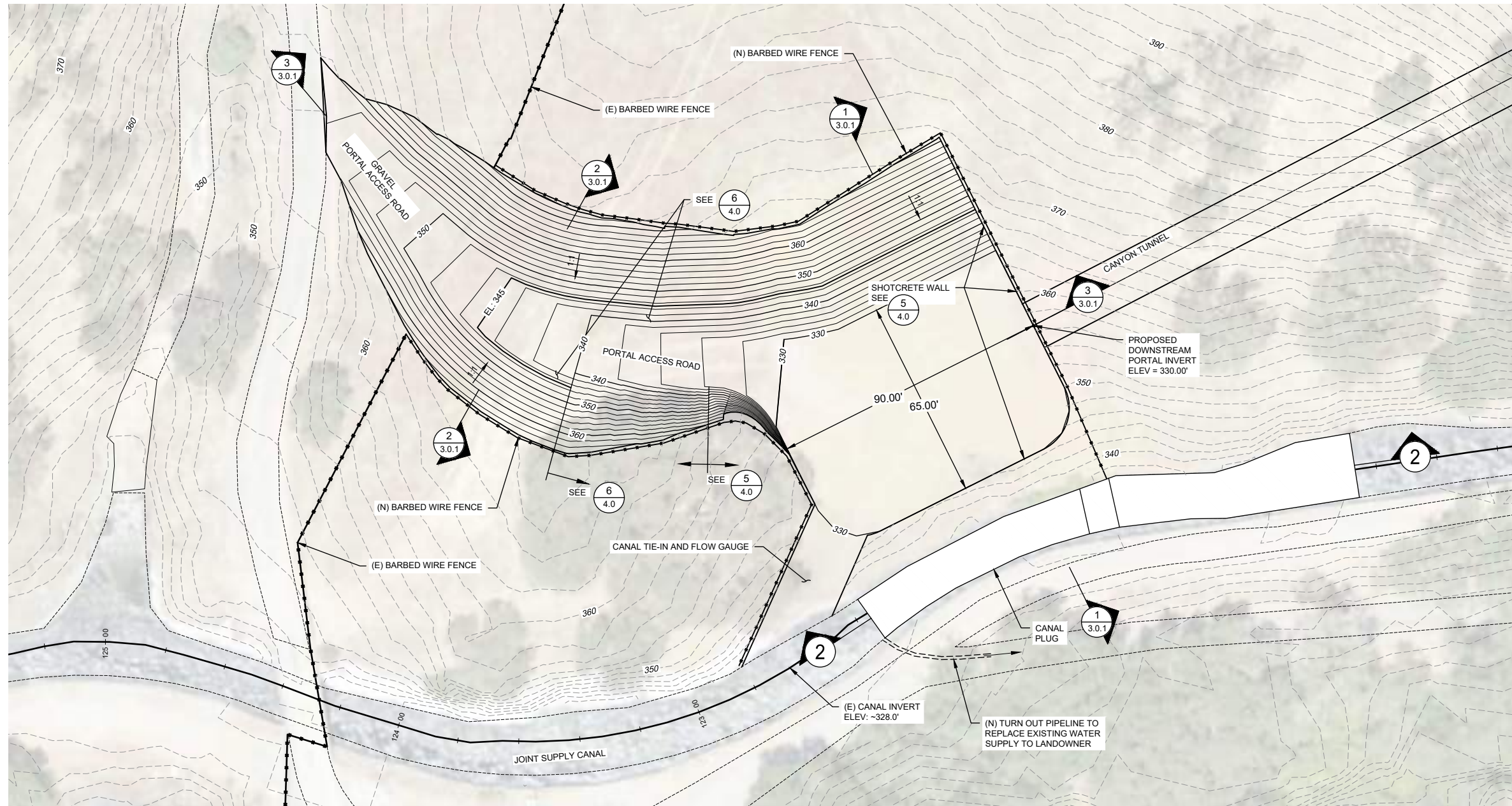

2 CANAL PLUG PROFILE
SCALE: N.T.S.

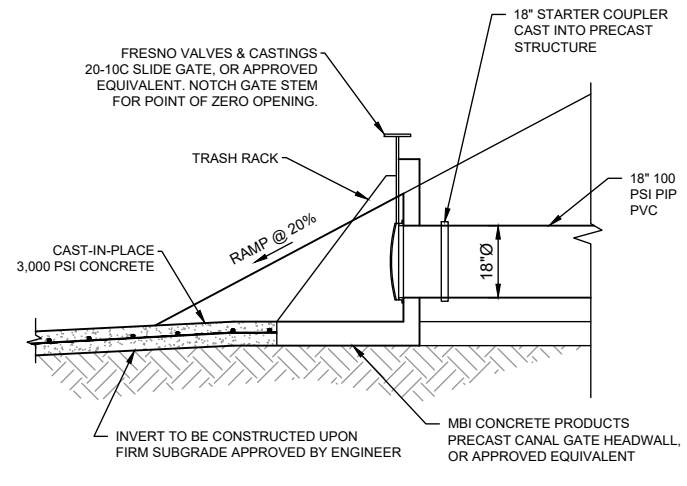

3 DRAIN PLUG GATE VALVE SECTION
SCALE: N.T.S.

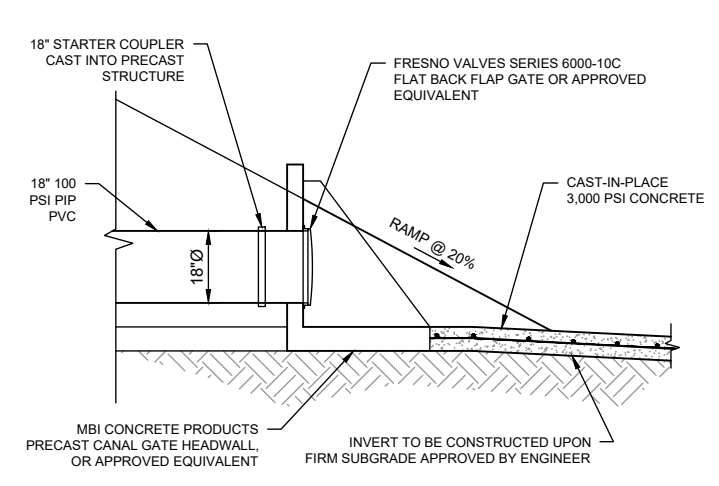

4 DRAIN PLUG FLAP GATE SECTION
SCALE: N.T.S.

DISCLAIMER: THIS PLAN REPRESENTS FEATURES FOR ILLUSTRATION PURPOSES ONLY. IT IS NOT A LEGAL SURVEY AND IS NOT INTENDED FOR USE IN DETERMINING BOUNDARIES OR DIMENSIONS. ANY USE OF THIS PLAN FOR PURPOSES OTHER THAN LOCATION OF FEATURES IS DONE SO AT THE USER'S RISK AND WITHOUT THE CONSENT OF PROVOST & PRITCHARD. SEE CIVIL DOCUMENTS FOR LOCATION OF BOUNDARIES AND FEATURES.

CANYON TUNNEL PROJECT
 SOUTH SAN JOAQUIN IRRIGATION DISTRICT
 CALAVERAS COUNTY, CALIFORNIA

DOWNSTREAM FACILITIES

60% DESIGN
 NOT FOR CONSTRUCTION
 11/04/2022

FOR REVIEW ONLY

NO.	REVISION	BY	DATE
1	60% DESIGN	SWL	11/04/2022

PROVOST & PRITCHARD
 CIVIL ENGINEERS
 1860 GREENEY RD. SUITE 100
 SONOMA, CALIFORNIA 95370
 559-494-2700 FAX 559-494-2715
 https://provostpritchard.com

DESIGN ENGINEER:
 ANDREW KOSITSKY
 LICENSE NO:
 GE 2532

DRAFTED BY: KGM
 CHECKED BY: SWL
 DATE: 11/04/2022
 JOB NO: 1055
 PROJECT NO: 22
 PHASE: 001

ORIGINAL SCALE SHOWN IS ONE INCH. ADJUST SCALE FOR REDUCED OR ENLARGED PLANS.
 SHEET **3.1**
 13 OF 23

11/3/2022 1:59 PM G:\South San Joaquin ID-1055\105522001-Canyon Tunnel 60% Design\300 CAD\340 Sheet Sns02_Plan_Maps\3.1 DOWNSTREAM FACILITIES.dwg - Ken McKinley

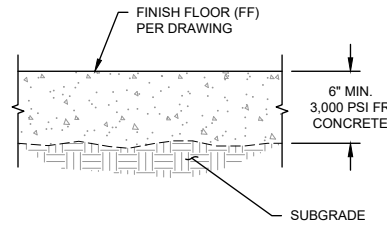

1 6-INCH MINIMUM CONCRETE SLAB

SCALE: N.T.S.

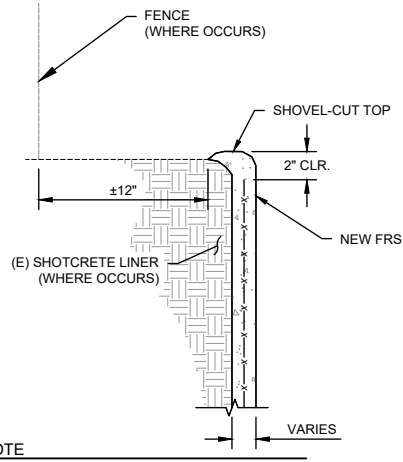

NOTE

- WHERE GRADE IS LEVEL OR SLOPES AWAY FROM SHOTCRETE, OR AT HARD ROCK SUBSTRATE.

2 TOP OF SHOTCRETE

SCALE: N.T.S.

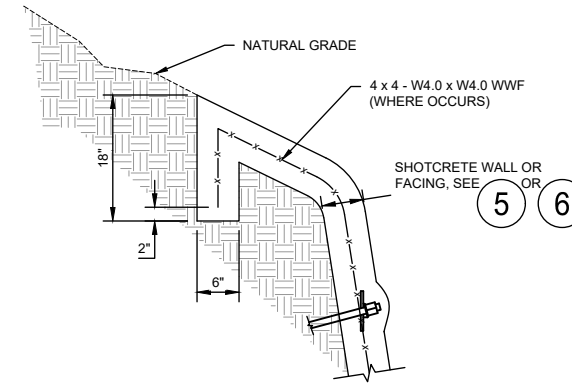

NOTE

- DRAIN TO CANAL OR SHOTCRETE SURFACE AT DISCHARGE POINT.
- WHERE GROUND SLOPES TO SHOTCRETE IN SOIL.

3 TOP OF SHOTCRETE

SCALE: N.T.S.

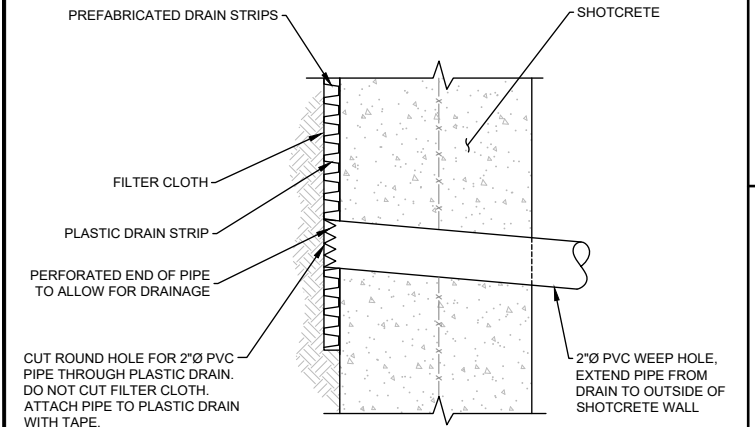

CUT ROUND HOLE FOR 2"Ø PVC PIPE THROUGH PLASTIC DRAIN. DO NOT CUT FILTER CLOTH. ATTACH PIPE TO PLASTIC DRAIN WITH TAPE.

2"Ø PVC WEEP HOLE. EXTEND PIPE FROM DRAIN TO OUTSIDE OF SHOTCRETE WALL

4 DRAIN STRIP WEEP HOLE DETAIL

SECTION SCALE: N.T.S.

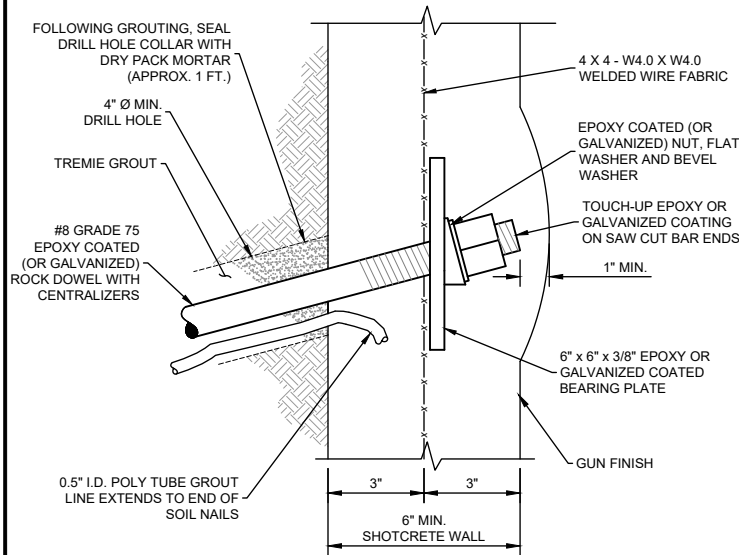

5 ROCK DOWEL AND SHOTCRETE FACING

SECTION SCALE: N.T.S.

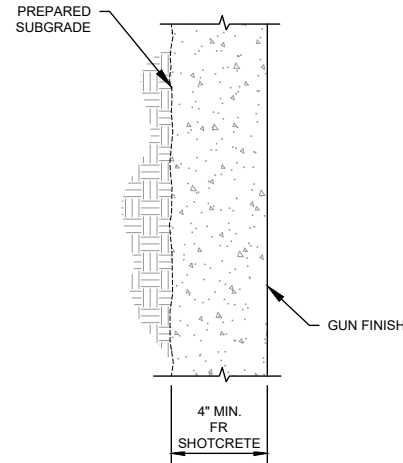

6 SHOTCRETE FACING

SCALE: N.T.S.

PROVOST & PRITCHARD ENGINEERING GROUP, INC. ALL RIGHTS RESERVED. The firm of Provost & Pritchard Engineering Group, Inc. expressly disclaims any and all liability for the use of these plans in any form or manner whatsoever, nor are they to be construed as a contract or agreement between the client and the firm of Provost & Pritchard Engineering Group, Inc. In the event of unauthorized reuse of these plans by a third party, the third party shall be liable for all damages and legal fees associated with defending and enforcing these rights.

60% DESIGN	11/04/2022	DATE
NOT FOR CONSTRUCTION	11/04/2022	BY
60% DESIGN	11/04/2022	REVISION
INC.		

FOR REVIEW ONLY

CANYON TUNNEL PROJECT
SOUTH SAN JOAQUIN IRRIGATION DISTRICT
CALAVERAS COUNTY, CALIFORNIA

PROVOST & PRITCHARD
ENGINEERING GROUP, INC.
1860 GREENEY RD. SUITE J
SONOMA, CALIFORNIA 95370
55949-2700 FAX 55949-2715
http://provostpritchard.com

DESIGN ENGINEER: ANDREW KOSITSKY LICENSE NO: GE 2532	CHECKED BY: SWL
DRAFTED BY: KGM	DATE: 11/04/2022
JOB NO: 1055	
PROJECT NO: 22	
PHASE: 001	
ORIGINAL SCALE SHOWN IS ONE INCH. ADJUST SCALE FOR REDUCED OR ENLARGED PLANS.	
SHEET 4.0	
14 OF 23	

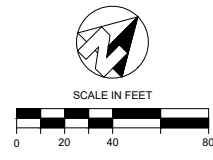

- NOTES**
1. BARGE AND CABLE GUIDE TO REMAIN AFTER CONSTRUCTION FOR FUTURE USE BY OWNER.
 2. EXISTING GOODWIN TUNNEL APPROXIMATELY 50 TO 100 FEET BELOW PROPOSED CANYON TUNNEL, TO BE VERIFIED.

COPYRIGHT 2022 BY PROVOST & PRITCHARD ENGINEERING GROUP, INC. ALL RIGHTS RESERVED. The firm of Provost & Pritchard Engineering Group, Inc. expressly warrants that the information contained herein was prepared by or copied in any form or manner whatsoever, nor are they to be reproduced, stored in a retrieval system, or transmitted in any form or by any means, electronic, mechanical, photocopying, recording, or by any information storage and retrieval system, without the prior written permission and consent of Provost & Pritchard Engineering Group, Inc. In the event of unauthorized reuse of these plans by a third party, the third party shall be liable for all damages, including reasonable attorneys' fees, and shall bear the cost of Provost & Pritchard Engineering Group, Inc.'s legal fees associated with defending and enforcing these rights.

NO.	REVISION	BY	DATE
1	60% DESIGN	SWL	11/04/2022

**60% DESIGN
NOT FOR CONSTRUCTION
11/04/2022**

FOR REVIEW ONLY

CANYON TUNNEL PROJECT
SOUTH SAN JOAQUIN IRRIGATION DISTRICT
CALAVERAS COUNTY, CALIFORNIA

**WATER FLOW CONTROL STRUCTURES
ALTERNATE 1A**



DESIGN ENGINEER: ANDREW KOSITSKY LICENSE NO: GE 2532	
DRAFTED BY: KGM	CHECKED BY: SWL
DATE: 11/04/2022	
JOB NO: 1055	
PROJECT NO: 22	
PHASE: 001	
ORIGINAL SCALE SHOWN IS ONE INCH. ADJUST SCALE FOR REDUCED OR ENLARGED PLANS.	
SHEET 5.0	
15 OF 23	

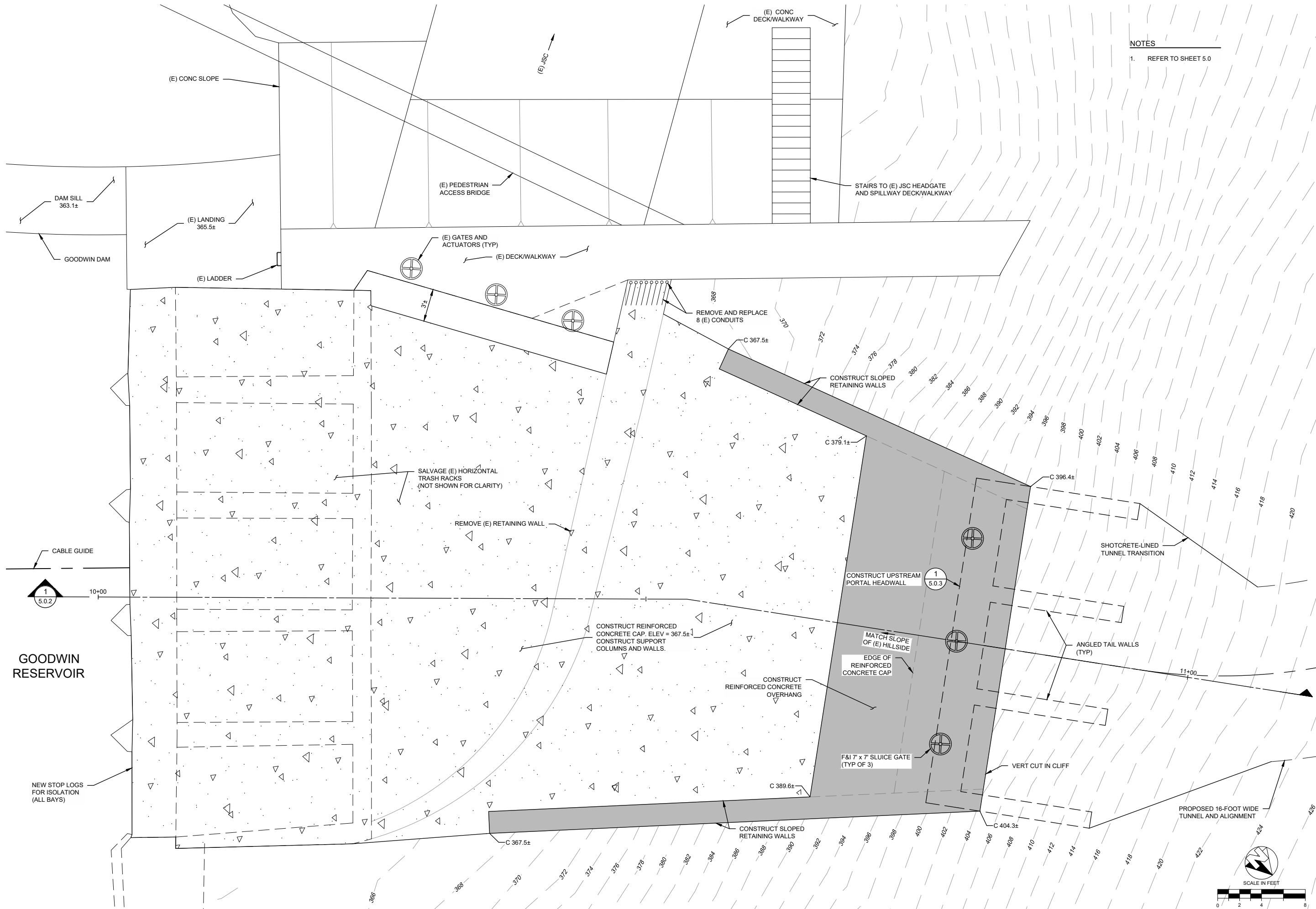

NOTES
 1. REFER TO SHEET 5.0

COPYRIGHT 2022 BY PROVOST & PRITCHARD ENGINEERING GROUP, INC. ALL RIGHTS RESERVED.
 The firm of Provost & Pritchard Engineering Group, Inc. expressly warrants that the design, drawings, specifications, reports, or other documents prepared by it or on its behalf are the work of its duly licensed professional engineers and architects. These documents are not to be reproduced, changed, or copied in any form or manner whatsoever, nor are they to be used for any purpose other than that specifically intended by the firm of Provost & Pritchard Engineering Group, Inc. in the event of unauthorized reuse of these plans by a third party, the third party shall be liable for all damages and shall bear the cost of defending and paying the reasonable attorneys' fees of Provost & Pritchard Engineering Group, Inc. and its members and shall bear the cost of defending and paying the reasonable attorneys' fees of Provost & Pritchard Engineering Group, Inc. in the event of any litigation or legal proceedings brought against the firm of Provost & Pritchard Engineering Group, Inc. or its members or any of its employees or agents.

60% DESIGN
NOT FOR CONSTRUCTION
 11/04/2022

INC.	BY	DATE
▲	SWL	11/04/2022

FOR REVIEW ONLY

CANYON TUNNEL PROJECT
 SOUTH SAN JOAQUIN IRRIGATION DISTRICT
 CALAVERAS COUNTY, CALIFORNIA

PROVOST & PRITCHARD
 CONSULTING ENGINEERS
 1860 GREENEY RD. SUITE 100
 SONOMA, CALIFORNIA 95070
 559.494.2700 FAX 559.494.2715
<http://www.provostpritchard.com>

DESIGN ENGINEER:
 ANDREW KOSITSKY
 LICENSE NO:
 GE 2532

DRAFTED BY: KGM
 CHECKED BY: SWL

DATE: 11/04/2022

JOB NO: 1055

PROJECT NO: 22

PHASE: 001

ORIGINAL SCALE SHOWN IS ONE INCH. ADJUST SCALE FOR REDUCED OR ENLARGED PLANS.

SHEET **5.0.1**
 16 OF 23

11/3/2022 2:01 PM G:\South San Joaquin ID-1055\105522001-Canyon Tunnel 80% Design\300 CAQ340 Sheet Sels 02_Plan_Maps\5.0.1 UPSTREAM PORTAL SITE PLAN.dwg -Ken McKinley

UPSTREAM PORTAL PROFILE

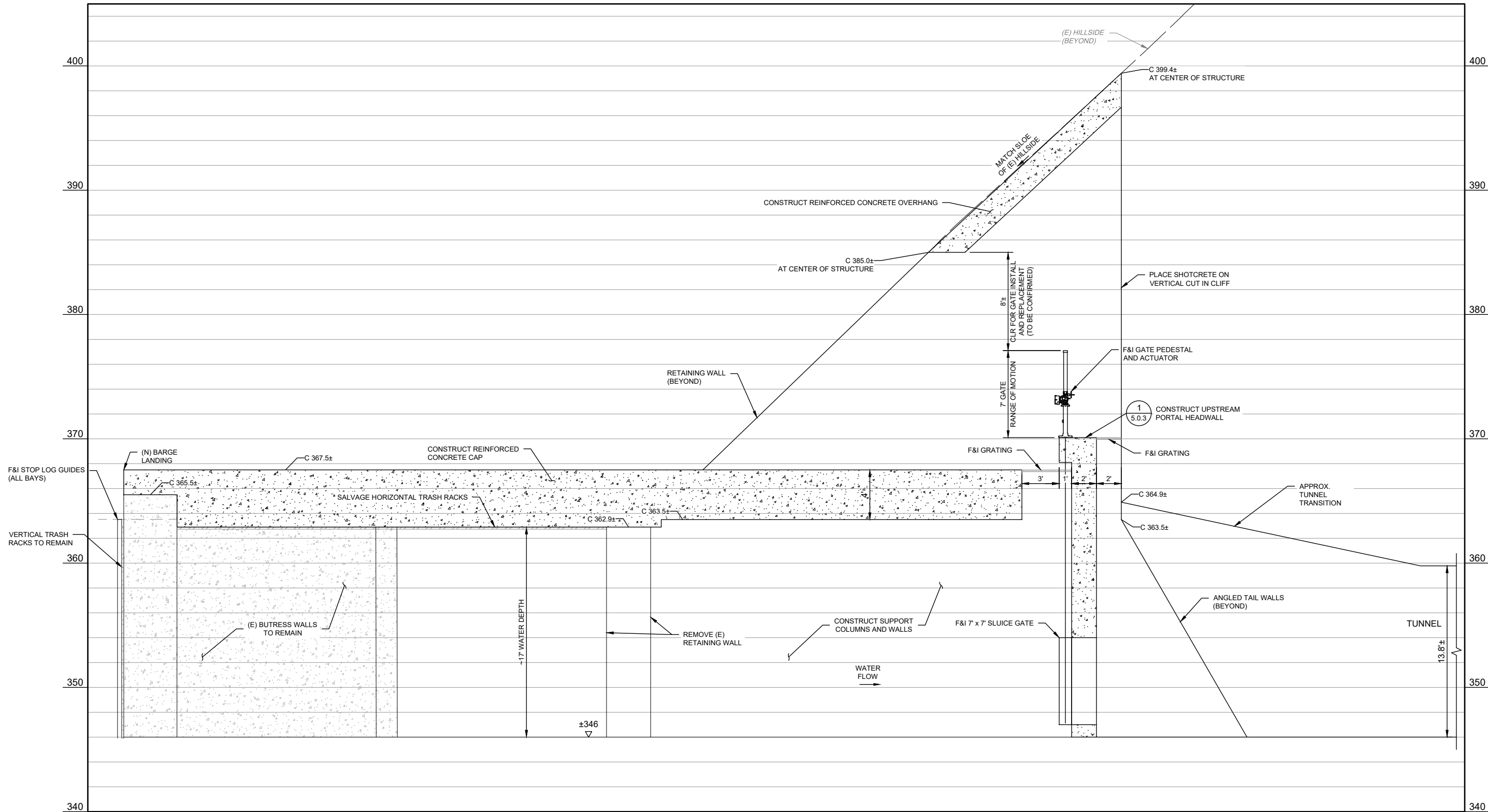

CANYON TUNNEL UPSTREAM PORTAL SECTION



1

COPYRIGHT 2022 BY PROVOST & PRITCHARD ENGINEERING GROUP, INC. ALL RIGHTS RESERVED. The firm of Provost & Pritchard Engineering Group, Inc. expressly warrants that the design and construction of the project shown on these plans is in accordance with the applicable laws, rules, regulations and codes of practice and standards of practice in effect at the time of preparation of these plans. These plans are not to be reproduced, changed or copied in any form or manner whatsoever, nor are they to be used for any purpose other than that specifically intended by the firm of Provost & Pritchard Engineering Group, Inc. in the event of unauthorized reuse of these plans by a third party, the third party shall be liable for all damages and shall bear the cost of defending and indemnifying the firm of Provost & Pritchard Engineering Group, Inc. from and against all claims, damages, losses and expenses, including reasonable attorneys' fees, associated with defending and enforcing these rights.

60% DESIGN	BY	DATE
NOT FOR CONSTRUCTION	SWL	11/04/2022
11/04/2022		

FOR REVIEW ONLY

CANYON TUNNEL PROJECT
SOUTH SAN JOAQUIN IRRIGATION DISTRICT
CALAVERAS COUNTY, CALIFORNIA

UPSTREAM PORTAL SECTION

DESIGN ENGINEER: ANDREW KOSITSKY LICENSE NO: GE 2532	
DRAFTED BY: KGM	CHECKED BY: SWL
DATE: 11/04/2022	
JOB NO: 1055	
PROJECT NO: 22	
PHASE: 001	
ORIGINAL SCALE SHOWN IS ONE INCH. ADJUST SCALE FOR REDUCED OR ENLARGED PLANS.	
SHEET 5.0.2	
17 OF 23	

11/3/2022 2:02 PM G:\South San Joaquin ID-1055\105522001-Canyon Tunnel 80% Design\300 CAD\340 Sheet Sels 03_Section 5.0.2 UPSTREAM PORTAL SECTION.dwg -Ken McKinley

2
5.0.3

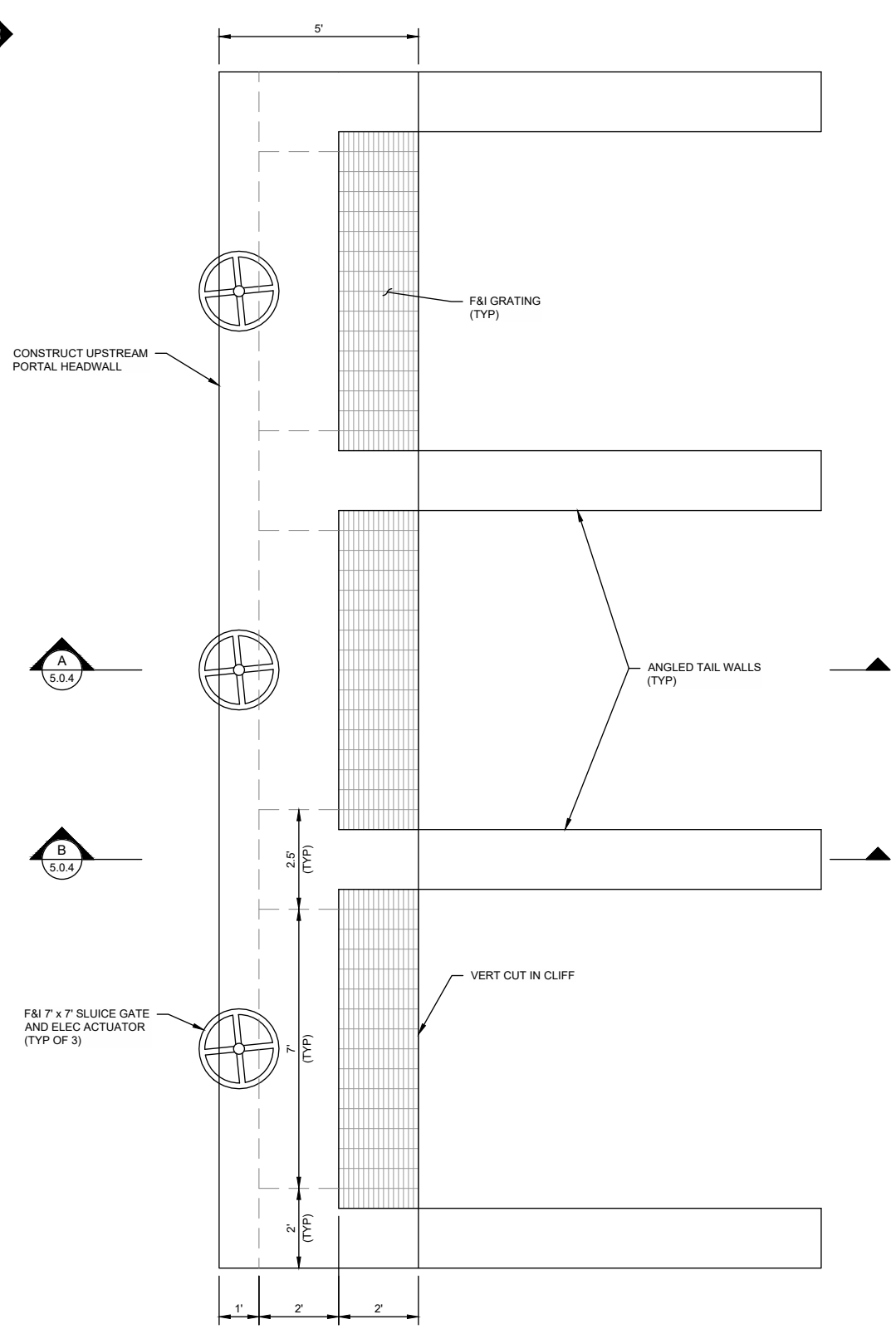

HEADWALL PLAN

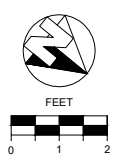

2

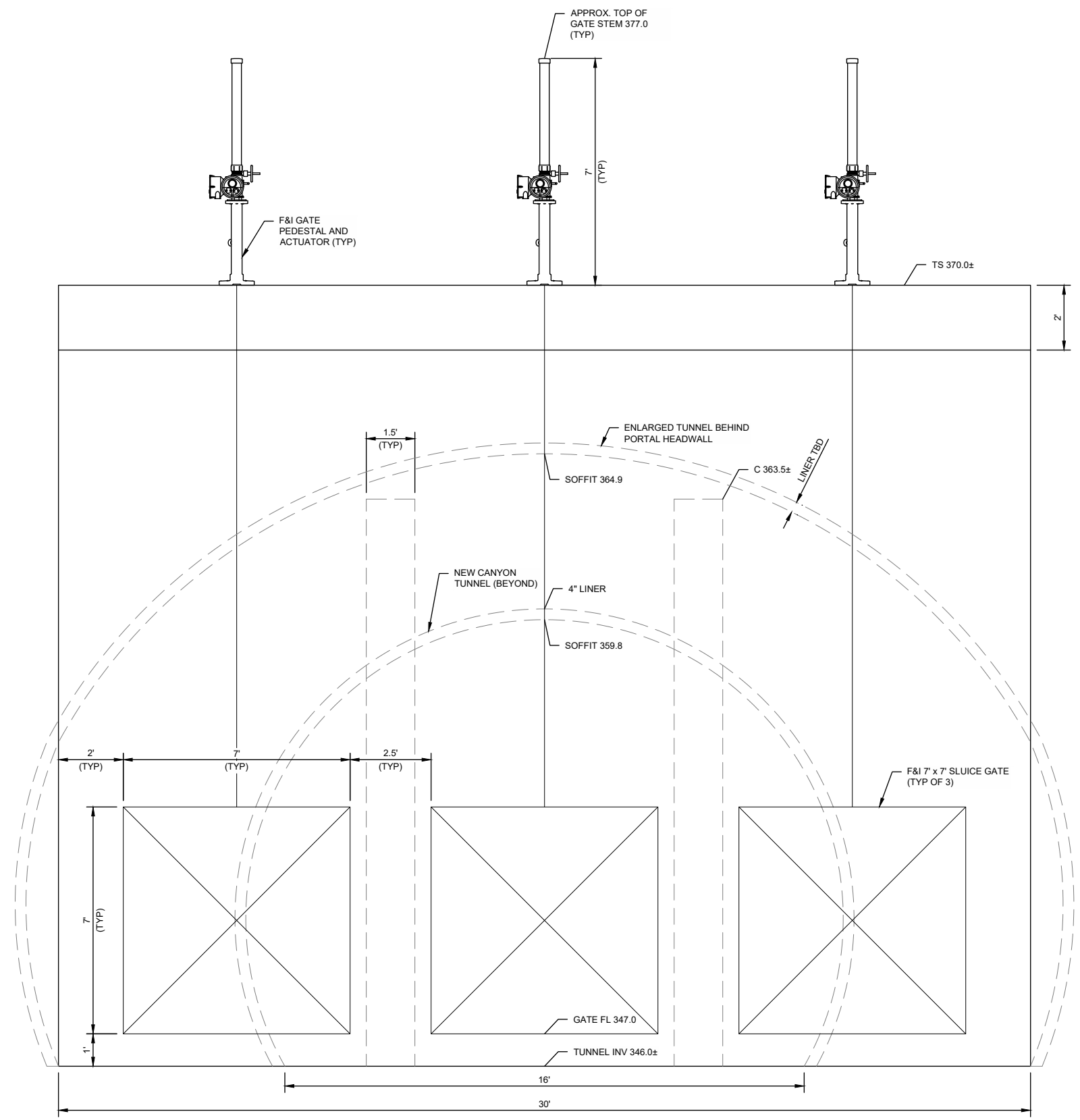

HEADWALL ELEVATION



COPYRIGHT 2022 BY PROVOST & PRITCHARD ENGINEERING GROUP, INC. ALL RIGHTS RESERVED.
 The firm of Provost & Pritchard Engineering Group, Inc. expressly disclaims any and all liability for the design, construction, or use of these plans. These plans are not to be reproduced, changed, or copied in any form or manner whatsoever, nor are they to be used for any purpose other than that specifically intended by the firm of Provost & Pritchard Engineering Group, Inc. In the event of unauthorized reuse of these plans by a third party, the third party shall be liable for all damages and shall bear the cost of Provost & Pritchard Engineering Group, Inc.'s legal fees associated with defending and enforcing these rights.

NO.	REVISION	BY	DATE
1	60% DESIGN	SWL	11/04/2022
60% DESIGN NOT FOR CONSTRUCTION 11/04/2022			

FOR REVIEW ONLY

CANYON TUNNEL PROJECT
 SOUTH SAN JOAQUIN IRRIGATION DISTRICT
 CALAVERAS COUNTY, CALIFORNIA

PROVOST & PRITCHARD
 ENGINEERS
 1860 GREENEY RD. SUITE 100
 SONOMA, CALIFORNIA 95370
 559-49-2700 FAX 559-49-2715
<http://www.provostpritchard.com>

DESIGN ENGINEER: ANDREW KOSITSKY LICENSE NO: GE 2532	CHECKED BY: SWL
DRAFTED BY: KGM	DATE: 11/04/2022
JOB NO: 1055	
PROJECT NO: 22	
PHASE: 001	
ORIGINAL SCALE SHOWN IS ONE INCH. ADJUST SCALE FOR REDUCED OR ENLARGED PLANS.	
SHEET 5.0.3	
18 OF 23	

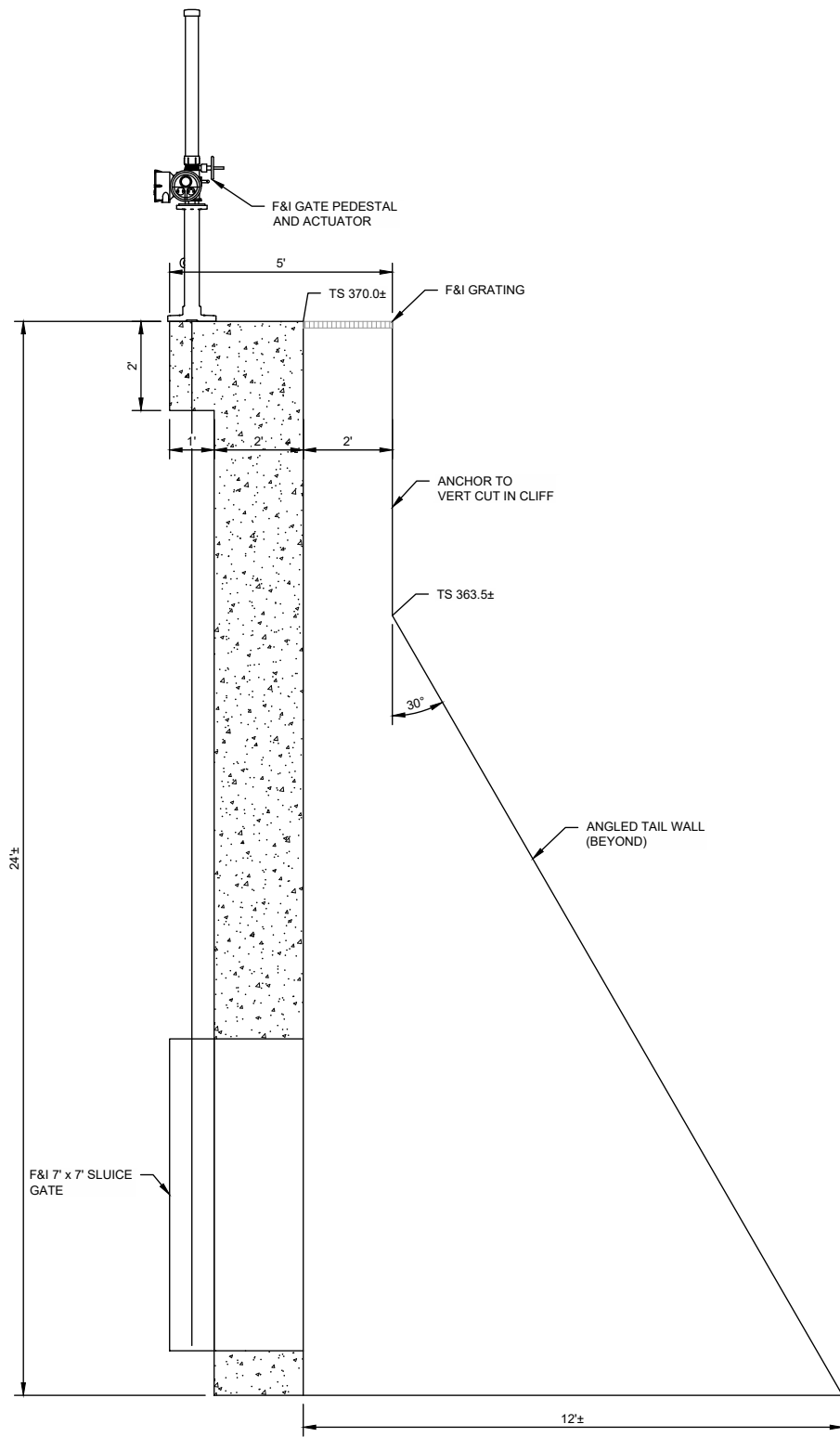

HEADWALL SECTION A

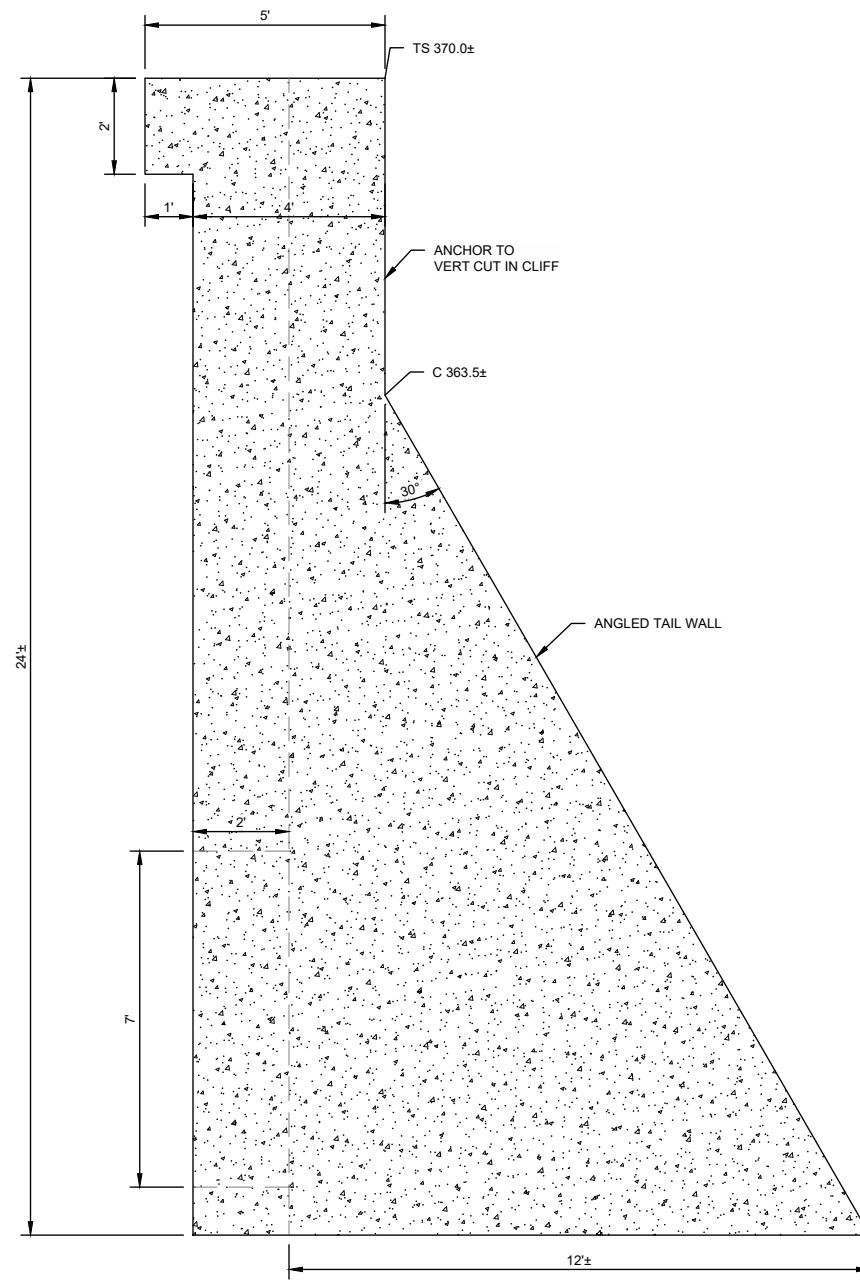

HEADWALL SECTION B



A

B

COPYRIGHT 2022 BY PROVOST & PRITCHARD ENGINEERING GROUP, INC. ALL RIGHTS RESERVED.
The firm of Provost & Pritchard Engineering Group, Inc. expressly warrants that the design, drawings, specifications, calculations, or data contained herein were prepared by or under the direct supervision and control of a duly licensed professional engineer and are true and correct to the best of our knowledge and belief. No part of this document may be reproduced, stored in a retrieval system, or transmitted in any form or by any means, electronic, mechanical, photocopying, recording, or by any information storage and retrieval system, without the prior written permission of Provost & Pritchard Engineering Group, Inc. In the event of unauthorized reuse of these plans by a third party, the third party shall be liable for all damages and shall bear the cost of Provost & Pritchard Engineering Group, Inc.'s legal fees associated with defending and enforcing these rights.

60% DESIGN
NOT FOR CONSTRUCTION
11/04/2022

FOR REVIEW ONLY

CANYON TUNNEL PROJECT
SOUTH SAN JOAQUIN IRRIGATION DISTRICT
CALAVERAS COUNTY, CALIFORNIA

UPSTREAM PORTAL ELEVATION



DESIGN ENGINEER:
ANDREW KOSITSKY
LICENSE NO:
GE 2532

DRAFTED BY: KGM
CHECKED BY: SWL

DATE: 11/04/2022
JOB NO: 1055

PROJECT NO: 22
PHASE: 001

ORIGINAL SCALE SHOWN IS ONE INCH. ADJUST SCALE FOR REDUCED OR ENLARGED PLANS.

SHEET 5.0.4

19 OF 23

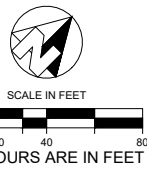
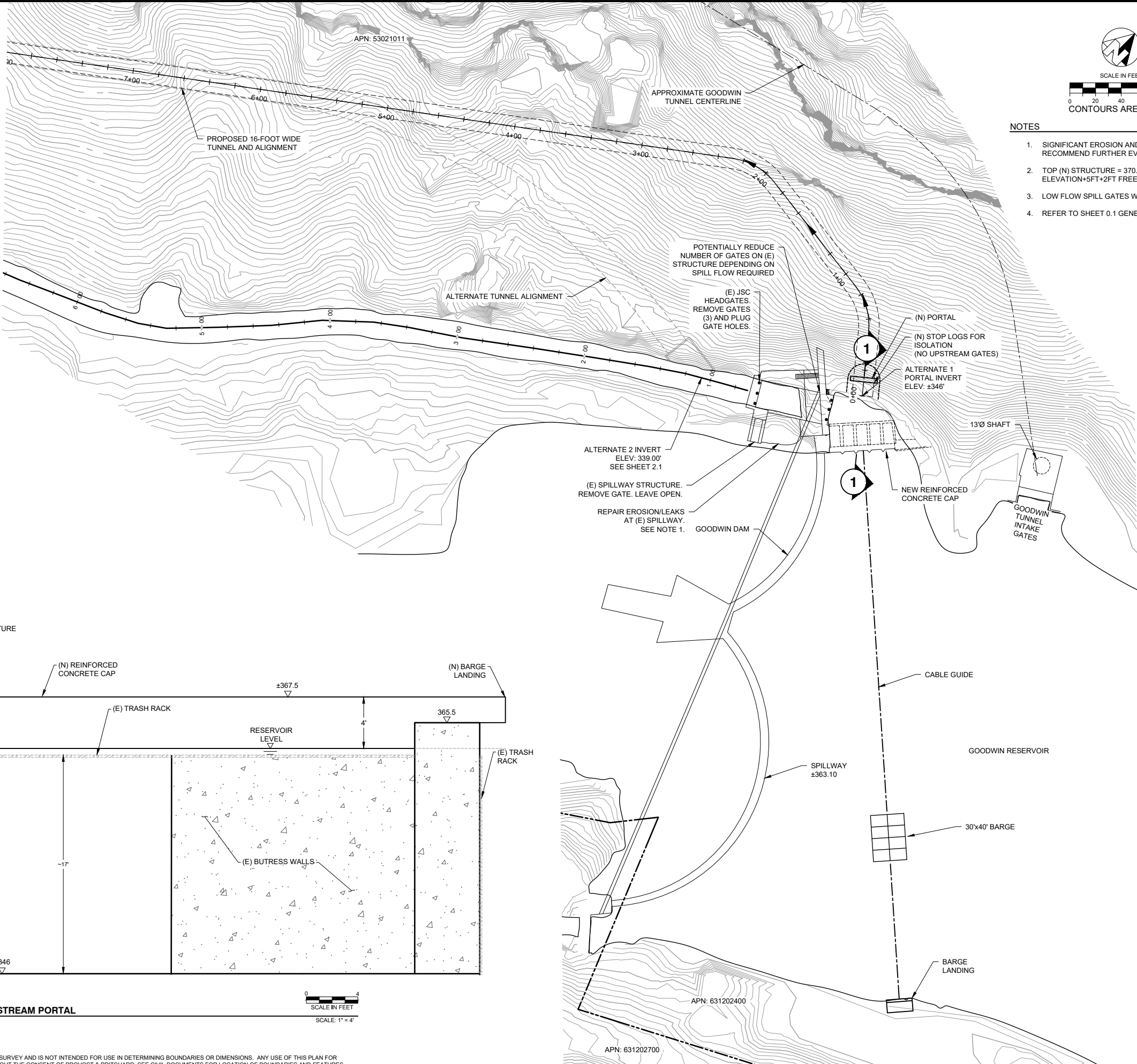

- NOTES**
- SIGNIFICANT EROSION AND LEAKS WERE OBSERVED. RECOMMEND FURTHER EVALUATION.
 - TOP (N) STRUCTURE = 370.10 (SPILLWAY ELEVATION+5FT+2FT FREEBOARD)
 - LOW FLOW SPILL GATES WILL NORMALLY BE CLOSED.
 - REFER TO SHEET 0.1 GENERAL NOTE 2.

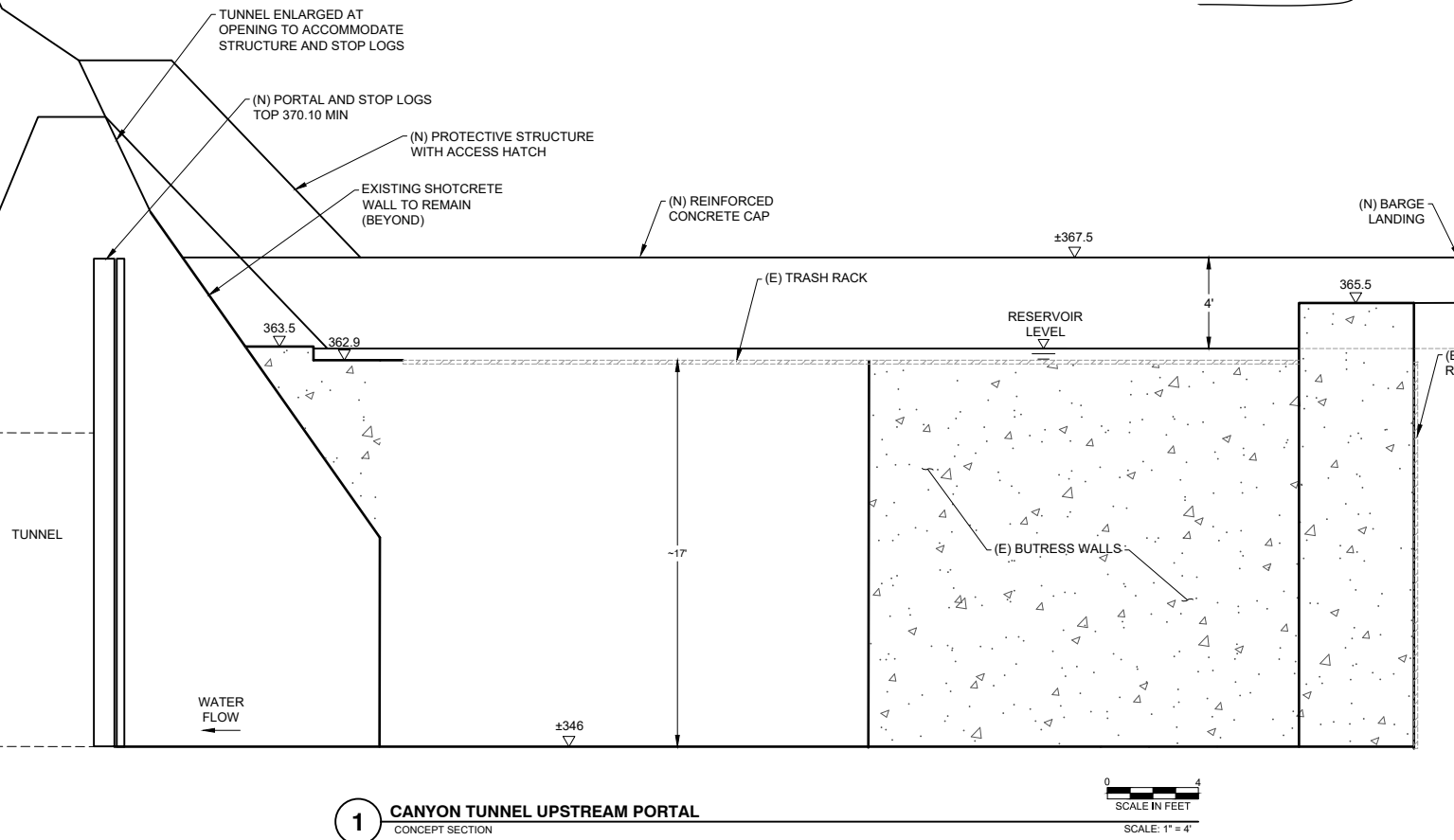

1 CANYON TUNNEL UPSTREAM PORTAL
CONCEPT SECTION
SCALE IN FEET
SCALE: 1" = 4'

DISCLAIMER: THIS PLAN REPRESENTS FEATURES FOR ILLUSTRATION PURPOSES ONLY. IT IS NOT A LEGAL SURVEY AND IS NOT INTENDED FOR USE IN DETERMINING BOUNDARIES OR DIMENSIONS. ANY USE OF THIS PLAN FOR PURPOSES OTHER THAN LOCATION OF FEATURES IS DONE SO AT THE USER'S RISK AND WITHOUT THE CONSENT OF PROVOST & PRITCHARD. SEE CIVIL DOCUMENTS FOR LOCATION OF BOUNDARIES AND FEATURES.

COPYRIGHT 2022 BY PROVOST & PRITCHARD ENGINEERING GROUP, INC. ALL RIGHTS RESERVED. The firm of Provost & Pritchard Engineering Group, Inc. expressly disclaims any and all liability for the use of these plans in any form or manner whatsoever, nor are they to be reproduced, stored in a retrieval system, or transmitted in any form or by any means, electronic, mechanical, photocopying, recording, or by any information storage and retrieval system, without the prior written consent of Provost & Pritchard Engineering Group, Inc. In the event of unauthorized reuse of these plans by a third party, the third party shall be liable for all damages, including reasonable attorneys' fees, incurred by Provost & Pritchard Engineering Group, Inc. The firm of Provost & Pritchard Engineering Group, Inc. is not responsible for any errors or omissions in these plans.

60% DESIGN NOT FOR CONSTRUCTION 11/04/2022	REVISION BY: SWL DATE: 11/04/2022
FOR REVIEW ONLY	
CANYON TUNNEL PROJECT SOUTH SAN JOAQUIN IRRIGATION DISTRICT CALAVERAS COUNTY, CALIFORNIA WATER FLOW CONTROL STRUCTURES ALTERNATE 2B	
DESIGN ENGINEER: ANDREW KOSITSKY LICENSE NO: GE 2532	
DRAFTED BY: KGM CHECKED BY: SWL	
DATE: 11/04/2022 JOB NO: 1055	
PROJECT NO: 22 PHASE: 001	
ORIGINAL SCALE SHOWN IS ONE INCH. ADJUST SCALE FOR REDUCED OR ENLARGED PLANS.	
SHEET 5.1	
20 OF 23	

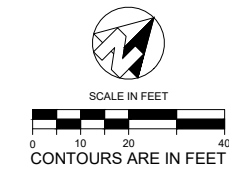

NOTES

1. DOWNSTREAM PORTAL INVERT GRADE MAY BE LOWERED FOR ALTERNATE 1B.
2. ENERGY DISSIPATION NEEDS FURTHER EVALUATION AND MAY BE REQUIRED FOR ACCURATE MEASUREMENT.
3. ELECTRIC GATE ACTUATOR WILL BE USED DUE TO EASE OF USE/INSTALL AND LESS ENVIRONMENTAL CONCERNS.
4. SLUICE GATES WOULD BE GATE OF CHOICE TO ALLOW FOR COMPLETE SHUTOFF.
5. REFER TO SHEET 0.1 GENERAL NOTE 2.

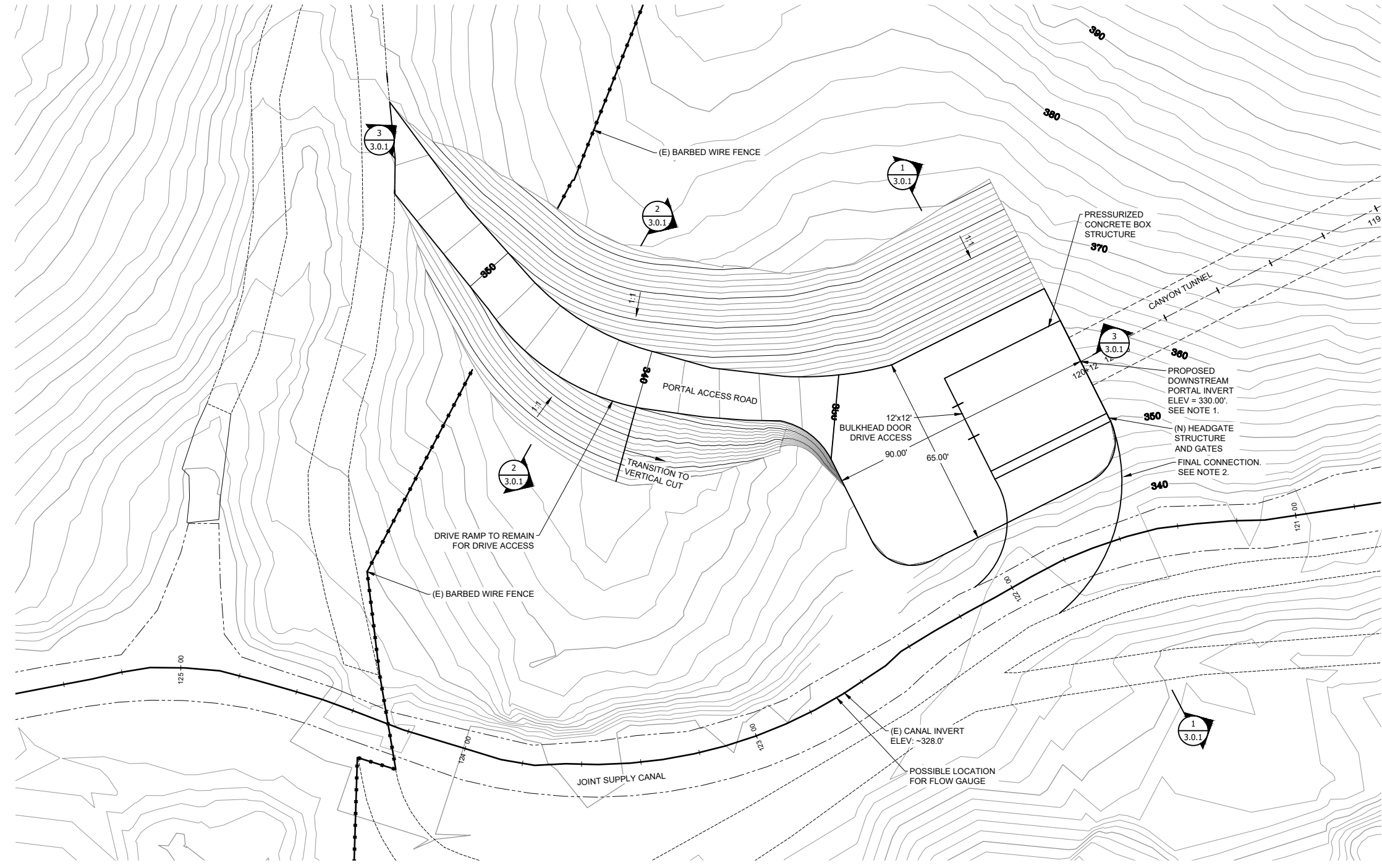

COPYRIGHT 2022 BY PROVOST & PRITCHARD ENGINEERING GROUP, INC. ALL RIGHTS RESERVED.
 The firm of Provost & Pritchard Engineering Group, Inc. expressly warrants that the information contained herein was prepared by its duly licensed professional engineers and surveyors and that the information is true and correct to the best of their knowledge and belief. This plan is not to be reproduced, changed or copied in any form or manner whatsoever, nor are they to be used for any purpose other than that specifically intended by the firm of Provost & Pritchard Engineering Group, Inc. In the event of unauthorized reuse of these plans by a third party, the third party shall be liable for all damages and shall bear the cost of Provost & Pritchard Engineering Group, Inc.'s legal fees associated with defending and enforcing these rights.

A	60% DESIGN	BY	SWL	DATE	11/04/2022
60% DESIGN NOT FOR CONSTRUCTION 11/04/2022					

FOR REVIEW ONLY

CANYON TUNNEL PROJECT
 SOUTH SAN JOAQUIN IRRIGATION DISTRICT
 CALAVERAS COUNTY, CALIFORNIA
**WATER FLOW CONTROL STRUCTURE
 ALTERNATE 1B DOWNSTREAM**

DESIGN ENGINEER: ANDREW KOSITSKY LICENSE NO: GE 2532	
DRAFTED BY: KGM	CHECKED BY: SWL
DATE: 11/04/2022	
JOB NO: 1055	
PROJECT NO: 22	
PHASE: 001	
ORIGINAL SCALE SHOWN IS ONE INCH. ADJUST SCALE FOR REDUCED OR ENLARGED PLANS.	
SHEET 5.1.1	
21 OF 23	

DISCLAIMER: THIS PLAN REPRESENTS FEATURES FOR ILLUSTRATION PURPOSES ONLY. IT IS NOT A LEGAL SURVEY AND IS NOT INTENDED FOR USE IN DETERMINING BOUNDARIES OR DIMENSIONS. ANY USE OF THIS PLAN FOR PURPOSES OTHER THAN LOCATION OF FEATURES IS DONE SO AT THE USER'S RISK AND WITHOUT THE CONSENT OF PROVOST & PRITCHARD. SEE CIVIL DOCUMENTS FOR LOCATION OF BOUNDARIES AND FEATURES.

11/3/2022 2:03 PM G:\South San Joaquin ID-1055\105522001-Canyon Tunnel 80% Design\300 CAQ340 Sheet Sns 02_Plan_Maps\5.1.1 WATER FLOW CONTROL STRUCTURE ALTERNATE 1B DOWNSTREAM.dwg -Ken McKinley

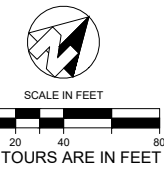
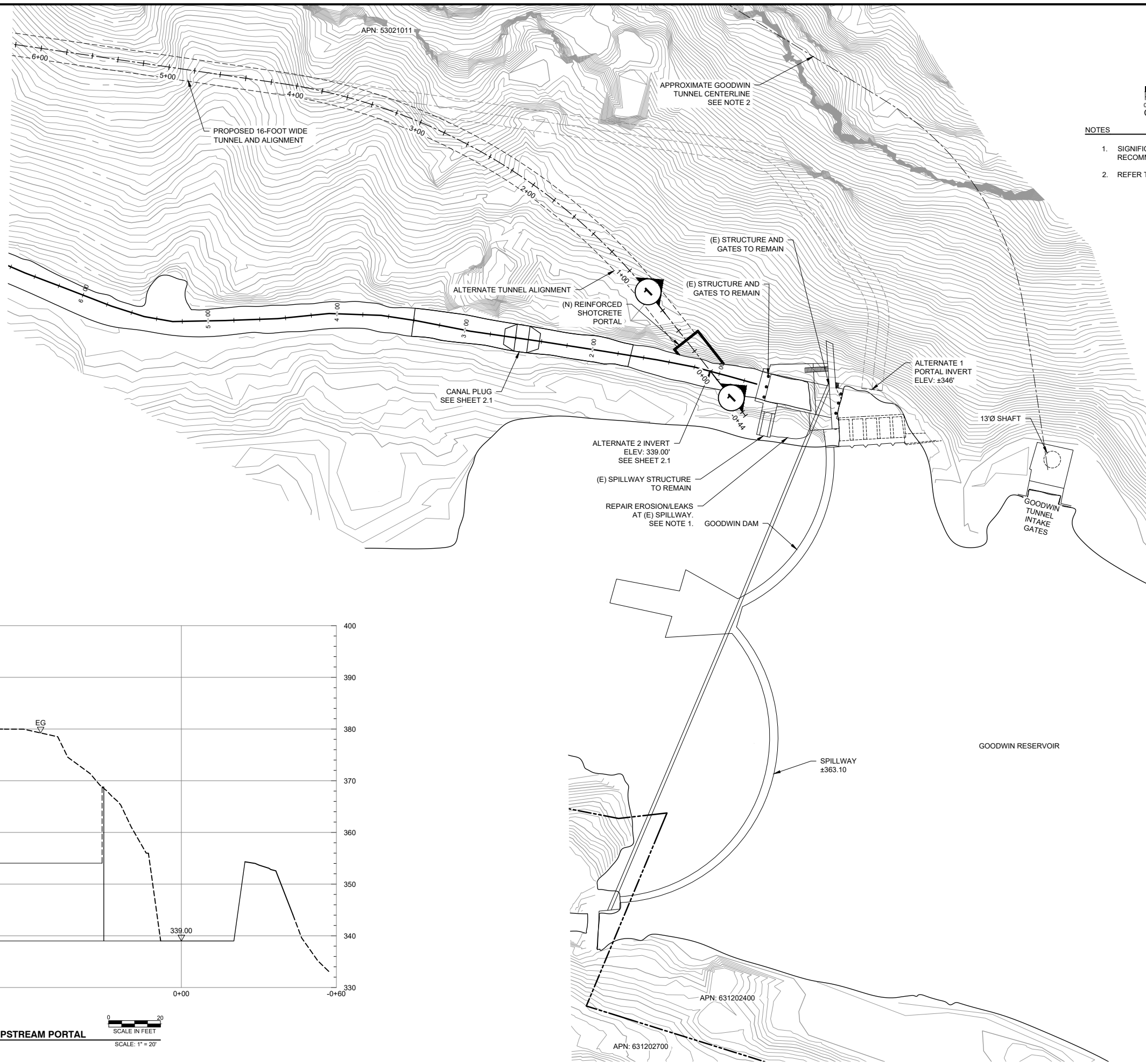

- NOTES**
- SIGNIFICANT EROSION AND LEAKS WERE OBSERVED. RECOMMEND FURTHER EVALUATION.
 - REFER TO SHEET 0.1 GENERAL NOTE 2.

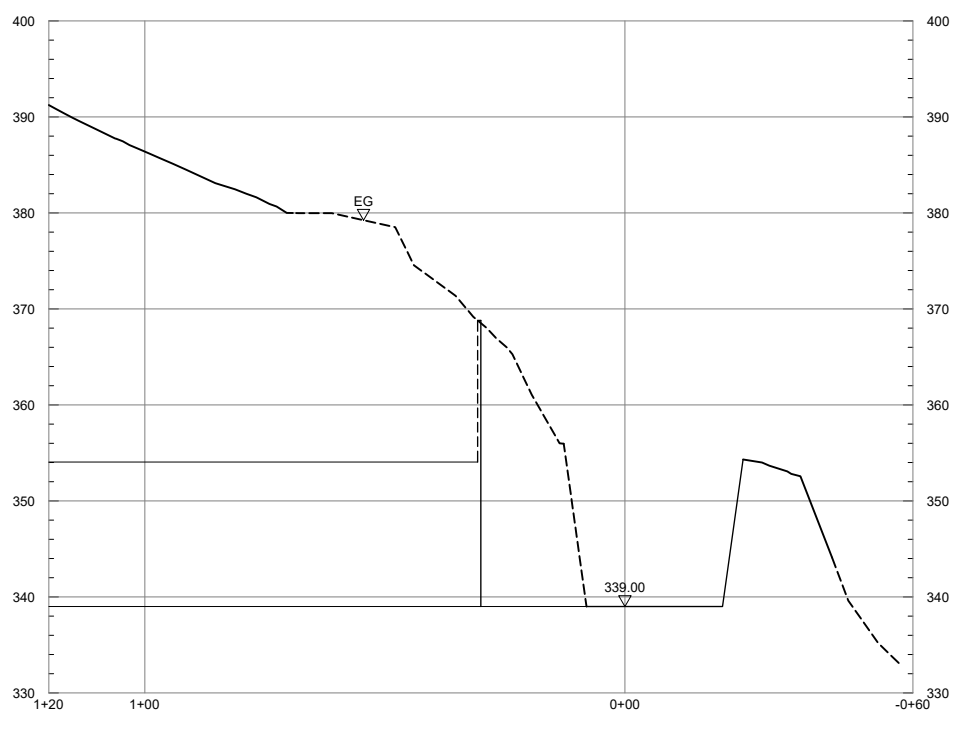

1 CANYON TUNNEL UPSTREAM PORTAL
PROFILE
SCALE: 1" = 20'

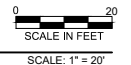

DISCLAIMER: THIS PLAN REPRESENTS FEATURES FOR ILLUSTRATION PURPOSES ONLY. IT IS NOT A LEGAL SURVEY AND IS NOT INTENDED FOR USE IN DETERMINING BOUNDARIES OR DIMENSIONS. ANY USE OF THIS PLAN FOR PURPOSES OTHER THAN LOCATION OF FEATURES IS DONE SO AT THE USER'S RISK AND WITHOUT THE CONSENT OF PROVOST & PRITCHARD. SEE CIVIL DOCUMENTS FOR LOCATION OF BOUNDARIES AND FEATURES.

PROVOST & PRITCHARD ENGINEERING GROUP, INC.
1860 GREENEY RD. SUITE J
SUNORA, CALIFORNIA 95370
559.449.2700 FAX 559.449.2715
http://provostpritchard.com

DESIGN ENGINEER:
ANDREW KOSITSKY
LICENSE NO: GE 2532

DRAFTED BY: KGM
CHECKED BY: SWL

DATE: 11/04/2022
JOB NO: 1055
PROJECT NO: 22
PHASE: 001

ORIGINAL SCALE SHOWN IS ONE INCH. ADJUST SCALE FOR REDUCED OR ENLARGED PLANS.

SHEET **5.2**
22 OF 23

CANYON TUNNEL PROJECT
SOUTH SAN JOAQUIN IRRIGATION DISTRICT
CALAVERAS COUNTY, CALIFORNIA
WATER FLOW CONTROL STRUCTURES
ALTERNATE 2A

60% DESIGN NOT FOR CONSTRUCTION
11/04/2022

FOR REVIEW ONLY

APN: 53021011
APN: 631202700
APN: 631202400

11/04/2022
SWL
BY
DATE
REVISION

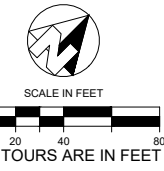
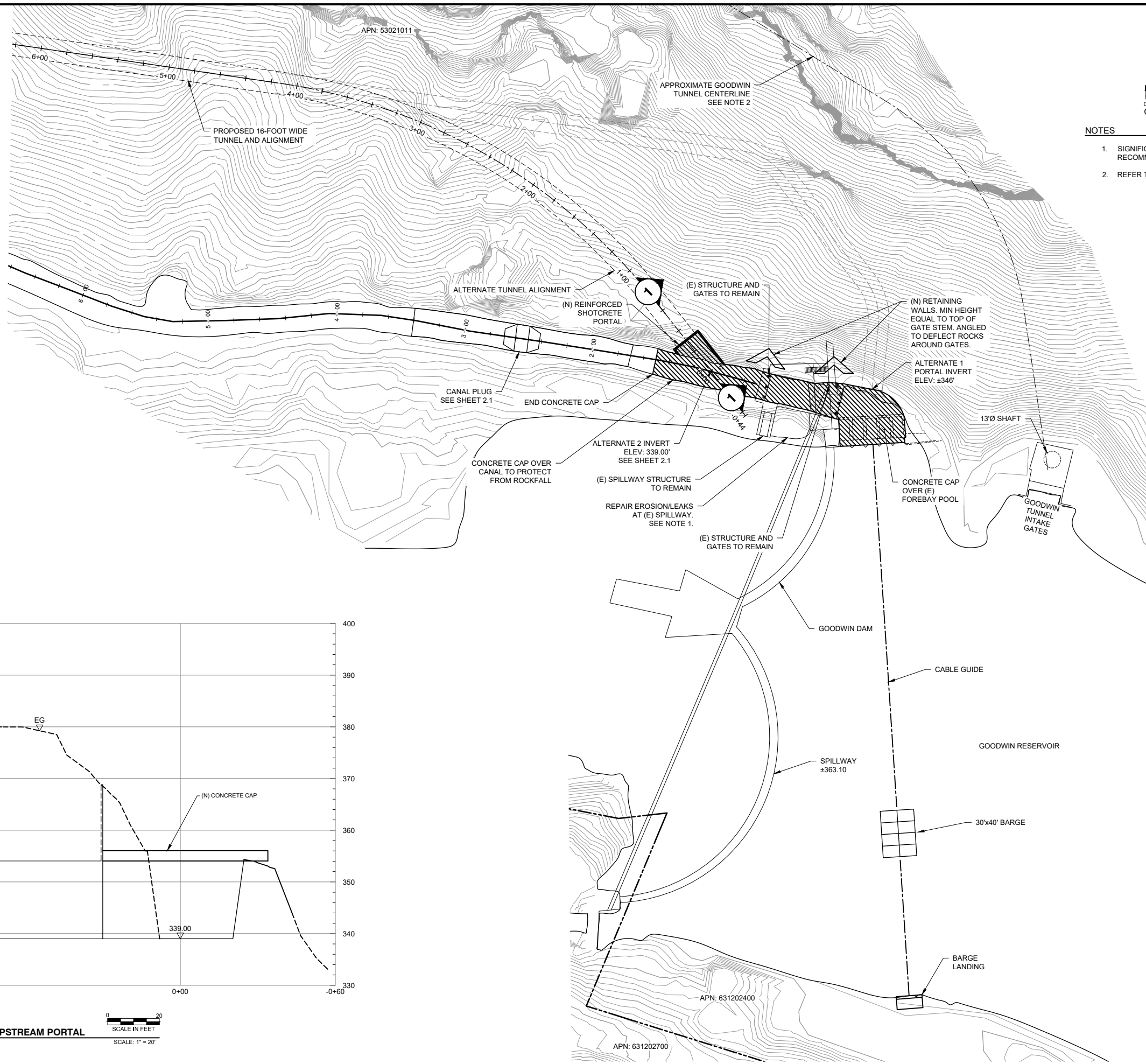

- NOTES**
- SIGNIFICANT EROSION AND LEAKS WERE OBSERVED. RECOMMEND FURTHER EVALUATION.
 - REFER TO SHEET 0.1 GENERAL NOTE 2.

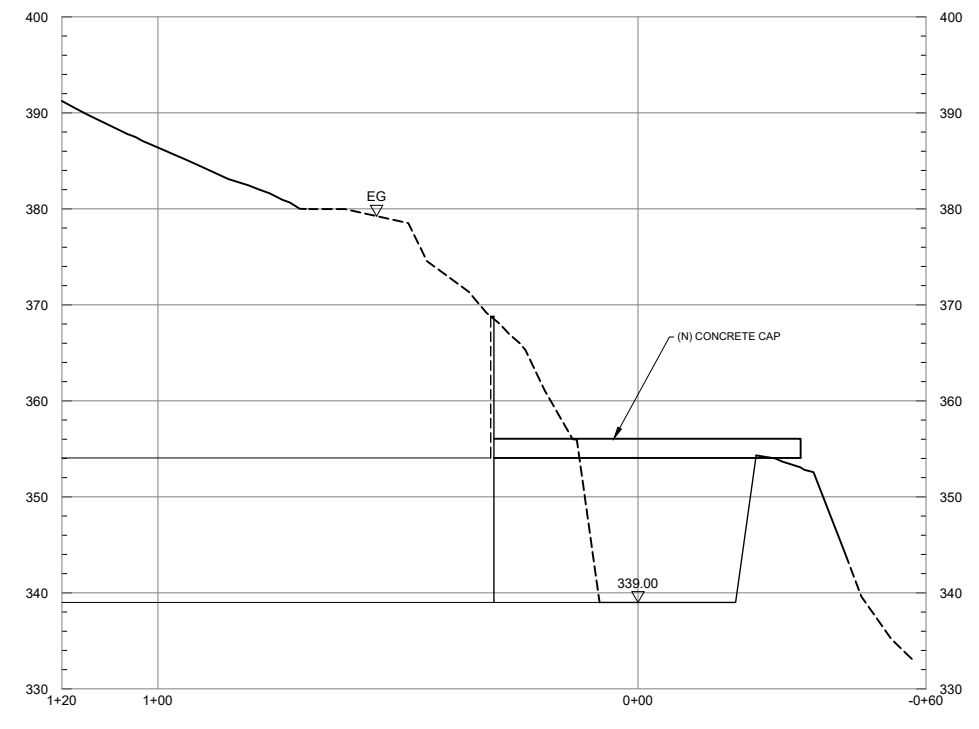

1 CANYON TUNNEL UPSTREAM PORTAL
PROFILE
SCALE IN FEET
SCALE: 1" = 20'

DISCLAIMER: THIS PLAN REPRESENTS FEATURES FOR ILLUSTRATION PURPOSES ONLY. IT IS NOT A LEGAL SURVEY AND IS NOT INTENDED FOR USE IN DETERMINING BOUNDARIES OR DIMENSIONS. ANY USE OF THIS PLAN FOR PURPOSES OTHER THAN LOCATION OF FEATURES IS DONE SO AT THE USER'S RISK AND WITHOUT THE CONSENT OF PROVOST & PRITCHARD. SEE CIVIL DOCUMENTS FOR LOCATION OF BOUNDARIES AND FEATURES.

COPYRIGHT 2022 BY PROVOST & PRITCHARD ENGINEERING GROUP, INC. ALL RIGHTS RESERVED.
The firm of Provost & Pritchard Engineering Group, Inc. expressly warrants that the information contained herein was prepared by or copied in any form or manner whatsoever, nor are they to be reproduced, stored in a retrieval system, or transmitted in any form or by any means, electronic, mechanical, photocopying, recording, or by any information storage and retrieval system, without the prior written permission and consent of Provost & Pritchard Engineering Group, Inc. In the event of unauthorized reuse of these plans by a third party, the third party shall be liable for all damages and shall bear the cost of Provost & Pritchard Engineering Group, Inc.'s legal fees associated with defending and enforcing these rights.

INC.	BY	DATE
60% DESIGN	SWL	11/04/2022
REVISION		

60% DESIGN
NOT FOR CONSTRUCTION
11/04/2022

FOR REVIEW ONLY

CANYON TUNNEL PROJECT
SOUTH SAN JOAQUIN IRRIGATION DISTRICT
CALAVERAS COUNTY, CALIFORNIA
WATER FLOW CONTROL STRUCTURE
ALTERNATE 2B

PROVOST & PRITCHARD
ENGINEERS
1860 GREENEY RD. SUITE J
SUNORA, CALIFORNIA 95370
559.449.2700 FAX 559.449.2715
http://provostpritchard.com

DESIGN ENGINEER:
ANDREW KOSITSKY
LICENSE NO:
GE 2532
DRAFTED BY: KGM
CHECKED BY: SWL
DATE: 11/04/2022
JOB NO: 1055
PROJECT NO: 22
PHASE: 001

ORIGINAL SCALE SHOWN IS ONE INCH. ADJUST SCALE FOR REDUCED OR ENLARGED PLANS.
SHEET **5.3**

ATTACHMENT C

South San Joaquin Irrigation District
Oakdale Irrigation District

Sixty Percent Design Report Canyon Tunnel

Calaveras County, California
November 4, 2022

Prepared for
South San Joaquin Irrigation District
PO Box 747
Ripon, CA 95366-9750

Prepared by:
Provost & Pritchard Consulting Group
19969 Greenley Road, Suite J
Sonora, California
Job No. 1055-22-001

TABLE OF CONTENTS

1.0	EXECUTIVE SUMMARY	1
2.0	DESIGN	2
2.1	INTRODUCTION	2
2.1.1	Purpose	2
2.1.2	Background	2
2.1.3	Services Provided.....	4
2.2	ASSUMPTIONS	4
2.2.1	Hydraulic Analysis	4
2.2.2	Geology Along Tunnel Alignment.....	5
2.3	RECOMMENDATIONS	7
2.3.1	Tunnel Alignment.....	7
2.3.2	Upstream Portal Alternates.....	8
2.3.3	Downstream Facilities.....	10
2.3.4	Tunnel Construction Methods	10
3.0	PRELIMINARY CONSTRUCTION COST ESTIMATE.....	12
3.1	APPROACH	12
3.2	CONSTRUCTION COST SUMMARY	13
4.0	PROJECT SCHEDULE AND SOFT COSTS.....	14
4.1	ENGINEERING, DESIGN AND PRE-CONSTRUCTION.....	15
4.2	CALIFORNIA ENVIRONMENTAL QUALITY ACT PERMITTING AND MONITORING	15
4.3	LAND ENTITLEMENT	15
4.4	CONSTRUCTION MANAGEMENT AND INSPECTION	16
4.5	TOTAL PROJECT SOFT COSTS AND SCHEDULE	16
5.0	LIMITATIONS	16
6.0	CLOSURE.....	17

ATTACHMENTS

APPENDIX A

Geologic Hazards Study – Upstream Portal

APPENDIX B

60 Percent Design Drawings (reduced scale)

APPENDIX C

Preliminary Hydraulic Analysis

APPENDIX D

Preliminary Engineer’s Opinion of Probable Construction Cost Estimate

Sixty Percent Design Report Canyon Tunnel

South San Joaquin Irrigation District Oakdale Irrigation District Calaveras County, California

1.0 EXECUTIVE SUMMARY

Significant potential rock fall and rockslide hazards that pose substantial risk to future water delivery and worker safety have been identified along a segment of the South San Joaquin Irrigation District (SSJID) and Oakdale Irrigation District (OID) Joint Supply Canal (JSC) between Goodwin Dam and the SSJID Main Canal/OID North Main Canal Diversion Works. SSJID provides JSC maintenance and is the lead agency for this project. Provost and Pritchard Consulting Group (P&P) has prepared a preliminary design for a bypass tunnel (Canyon Tunnel) to avoid the high-risk areas.

The proposed Canyon Tunnel begins near Goodwin Dam and ties into the JSC approximately 2 miles downstream, near the existing canal access ramp between the Gable Tunnel and the Long Tunnel. The proposed Canyon Tunnel will be approximately 12,000 feet long. P&P developed the proposed alignment based on evaluation of subsurface ground conditions revealed during the geological drilling and exploration program; the alignment generally follows the softer ground of the Mehrten Formation and, to the extent possible, avoids strong to very strong basement rock of the Gopher Ridge Formation.

The proposed tunnel could be constructed using either conventional (roadheader) or Tunnel Boring Machine (TBM) tunneling methods. The tunnel will be an inverted horseshoe shape at about 16 feet wide by 14 feet high (conventional tunneling methods) or an approximate 19-foot diameter circular tunnel with a flat concrete invert (TBM). However, owing to significantly higher risk factors and higher estimated construction costs, we recommend that the TBM option should be eliminated from further consideration for this project. Diesel-powered trucks and equipment will be able to transit through the completed tunnel for future maintenance.

The 60 percent design effort also included developing proposed tunnel inlet and outlet permanent facilities, as well as temporary facilities necessary to support the project construction. A detailed geologic hazards study was performed for the steep rock cliffs above the north abutment at Goodwin Dam; the study confirmed that significant geologic hazards are present that threaten the existing JSC inlet facilities. Therefore, alternate intake concepts were evaluated considering hazards mitigation, aspects including future maintenance access and ease of facilities operation, and construction costs. A draft version of this report was prepared in April 2021, but CEQA permitting work was determined to be necessary to confirm that the preferred alternate for the tunnel inlet and control structures upstream of Goodwin Dam would not require a fish screen structure and therefore would be feasible; the preferred alternative (Alternate 1) has since been confirmed, with no fish screen required.

Based on the assumptions described in this report, our preliminary opinion of probable construction costs for Alternate 1A (tunnel inlet and control structures upstream of Goodwin Dam)

is approximately \$39.5 million in 2021 construction dollars. We estimate that contractor bidding could occur in late 2024, that construction could begin in early to mid 2025 and that the construction duration will be approximately 36 months. P&P recommends that the preliminary total project cost budget should include annual escalation of the probable construction costs, soft costs (including remaining limited site exploration, engineering, CEQA permitting and compliance, construction management, etc.), and contingencies; we therefore recommend a preliminary overall budget for remaining work items of \$61.6 million for 2025 - 2028 construction.

2.0 DESIGN

2.1 INTRODUCTION

This report presents the progress results of our ongoing engineering evaluation and design of a water conveyance “bypass” tunnel. The work completed to date, as described below, began with the tunnel design team previously employed by Condor Earth (Condor). The team transitioned to P&P and has continued with completing the 60 percent design under P&P.

Evaluation of the bypass tunnel was a result of recommendations presented in the Condor 2018 update to the Phase 2 Improvement Evaluation study for the joint SSJID and OID canal system. The bypass tunnel, herein referred to as the Canyon Tunnel, is located within the JSC system northeast of Knights Ferry, CA. SSJID is the lead agency for this Project. P&P has performed and finalized this phase of the work in accordance with our Client Consent Form dated January 3, 2022 authorizing the transfer of the Condor agreement and Proposal for Engineering Services – 60 Percent Design, Canyon Tunnel, Joint Supply Canal, dated April 9, 2020.

2.1.1 Purpose

This design report presents the proposed tunnel and the conceptual portal/control structure design at a 60 percent design level. The primary purpose of this effort is to evaluate the preferred tunnel alignment and dimensions, tunnel intake and outlet arrangements and alternatives, temporary facilities, and to provide an updated construction cost estimate for the project considering design developments made and additional subsurface data retrieved since the completion of the 30 percent design phase. The parameters described herein include the preferred tunnel alignment and dimensions, alternate portal configurations that were considered, and potential construction methods. The results of the 60 percent engineering design effort may be used as a basis for environmental permitting, land acquisition and 90 percent design for the project.

2.1.2 Background

The tunnel design team has provided support for evaluations and improvements to the JSC system for the past 15+ years. Other reports prepared by P&P’s team that are pertinent to the proposed Canyon Tunnel include:

- 1) *Joint Main Canal and Tunnels Improvement Project, Long-Term Improvement Evaluation, Phase 2 Report, South San Joaquin Irrigation District*, originally provided August 20, 2007 and updated January 26, 2018
- 2) *Canyon Tunnel Thirty Percent Design Report, South San Joaquin Irrigation District*, dated April 9, 2020
- 3) *Project Description for the Proposed Canyon Tunnel Project*, April 29, 2021

- 4) *5-Year Maintenance Plan Recommendations, Joint Supply Canal, South San Joaquin Irrigation District*, updated October 6, 2021
- 5) *Geologic Data Report, Canyon Tunnel, South San Joaquin Irrigation District*, 60 Percent dated November 4, 2022
- 6) *Geologic Hazards Study – Upstream Portal, Canyon Tunnel, South San Joaquin Irrigation District*, dated November 4, 2022

The 2007 and 2018 Phase 2 Reports evaluated geologic hazards along the JSC between Goodwin Dam and the Diversion Works and provided an opinion of hazard severity levels (low, medium or high) for various segments of the canal system. Furthermore, we evaluated several options for canal improvements and maintenance, and we explored alternative water conveyance systems to increase water storage and mitigate the risk of canal shutdowns for emergency repairs. Alternatives for mitigating the rockslide hazards above the canal included constructing a protective cover over the canal, re-constructing the canal further out-slope, installing rockfall protection along the slope above the canal, and constructing one or more bypass tunnels to avoid the high-risk areas.

The 2018 update to the Phase 2 Report also included construction cost estimates for the various canal improvement alternatives. The tunnel construction costs were “benchmarked” based on the contractor bid prices received in 2017 by OID for the nearby Two-Mile Bar Tunnel Project (now known as Webb Tunnel). Based on the construction costs, estimated future maintenance efforts, and estimated overall remaining hazards after hypothetical completion of the various mitigation alternatives, our team recommended construction of a single bypass tunnel from Goodwin Dam to the canal access ramp (“Bypass Tunnel 3” in the 2018 Report) as the most reliable method for improving the JSC for continued long-term use. The Canyon Tunnel design work described herein is a continuation of evaluating the bypass tunnel alternative.

Our team has provided support for interim maintenance repairs to the JSC system intermittently since 2007. We developed the initial 5-Year Maintenance Plan Recommendations in 2019/2020, which detailed the recommended scope for short-term repairs and hazard mitigation measures between Goodwin Dam and the canal access ramp (“bypass segment”; the segment of the JSC to be bypassed by the proposed Canyon Tunnel) as well as permanent repairs warranted between the canal access ramp and the Diversion Works (the segment of canal to remain in operation following completion of the proposed Canyon Tunnel). The primary intent of the temporary repairs along the bypass segment of the JSC was to provide safe, reliable worker access and water conveyance through the canal until the bypass tunnel is completed.

Temporary maintenance repairs were completed along high-hazard portions of the bypass segment of the JSC during the 2019/2020 and 2020/2021 maintenance seasons by a specialty rock slope maintenance contractor, per the recommendations provided by our team. As described in the October 2021 update to the 5-Year Maintenance Plan Recommendations report, the temporary maintenance repairs along the bypass segment are substantially complete. The remaining recommended repairs include long-term rock slope improvements along the JSC between the canal access ramp and the Diversion Works, which will remain in-use following completion of the bypass tunnel.

The November 2022 Geologic Hazards Study (Appendix A) details our preliminary evaluation of the rock fall hazards along the rock cliffs exposed directly above the northern abutment of

Goodwin Dam. We used the results of the Hazards Study to evaluate alternatives for the location of the upstream portal of the new bypass tunnel, conceptual designs of a protective barrier over the portal and inlet gates, and conceptual designs for permanent barge access to the portal, if needed.

The site investigation data (including geologic mapping, rock core drilling and subsurface investigation) gathered during the design work for the current tunnel project is presented in our November 4, 2022 Geologic Data Report, which is provided under separate cover.

2.1.3 Services Provided

Our scope of services conducted as part of this study included:

- Geologic mapping and subsurface exploration, the results of which are presented in a separate Geologic Data Report
- Performing a geologic hazards study for the upstream portal facilities
- Preliminary design of permanent upstream tunnel inlet and downstream outlet facilities
- Layout of anticipated temporary construction facilities
- Updating preliminary hydraulic analyses of the proposed tunnel to determine minimum tunnel dimensions and slopes to maintain the JSC water conveyance capacity
- Preparing a preliminary project description to facilitate CEQA studies (completed under Condor)
- Providing preliminary land acquisition support
- Updating probable construction cost estimates based on the preliminary design assumptions

2.2 ASSUMPTIONS

Preliminary design drawings that show the preferred tunnel alignment, the potential and preferred upstream portal alternates and the preferred downstream portal location are included in Appendix B. The potential tunnel dimensions and construction methods are based on the assumptions presented in the following subsections.

2.2.1 Hydraulic Analysis

We understand that the typical peak water flow of the JSC is approximately 1,100 cubic feet per second (cfs). We developed the minimum tunnel dimensions and conducted our analyses based on a design flow capacity of 1,250 cfs.

We evaluated two upstream portal locations with differing finished invert grades: one immediately upstream of Goodwin Dam (Alternate 1) at finished invert grade of ± 346 feet above sea level (+MSL), and one approximately 100 feet downstream of Goodwin Dam (Alternate 2) at a finished invert grade of ± 339 feet +MSL. Our hydraulic analyses assumed a fixed (preferred) location of the downstream portal at a finished grade of ± 330 feet +MSL and a uniform longitudinal slope between the portals for each alternative. A discussion of the upstream portal alternates is included in Section 2.3.2.

Our hydraulic analyses were performed with a focus on determining the minimum tunnel dimensions that would be required to convey the desired peak water flows without the tunnel pressurizing (i.e. maintaining open-channel flow). The minimum dimensions of the proposed tunnel are dependent upon the potential means and methods of tunnel construction and the longitudinal slope along the tunnel alignment; therefore, alternatives for minimum tunnel section dimensions (conventional and TBM) were considered in the hydraulic analyses, which are included as Appendix C.

The potential tunnel sections are presented on Sheet 1.2 of the 60 Percent Design Drawings included in Appendix B. Sections A and B are inverted horseshoe shape and assume that the tunnel will be constructed with conventional tunneling methods. Section A has a finished width of 16.0 feet at the invert, a finished height of 13.8 feet and a finished area of approximately 214 square feet (sf). Section B has a finished width of 17.5 feet at the invert, a finished height of 15.1 feet and a finished area of approximately 256 sf. If the tunnel is constructed with a TBM, our analysis indicates that a finished diameter of approximately 19.5 feet (Section C; finished area approximately 290 sf) is required to accommodate the design water flows and a flat concrete invert necessary for reliable vehicle access through the finished tunnel. The portal invert elevations, longitudinal slopes, lengths and minimum dimensions of the tunnel for each alternate are shown in Table 1.

TABLE 1
Proposed Tunnel Invert Slope Alternatives used in Hydraulic Analyses

Upstream Portal Location	Upstream Portal Finished Invert Grade (ft.)	Downstream Portal Finished Invert Grade (ft.)	Slope (DGrade ÷ Length)	Tunnel Length (ft.)	Tunnel Dimensions
Alternate 1	346	330	.0013	12,012	Conventional: Section A TBM: Section C
Alternate 2	339	330	.0008	11,836	Conventional: Section B TBM: Section C

2.2.2 Geology Along Tunnel Alignment

The geologic conditions present at the site and the results of our surface and subsurface investigations are presented in the Geologic Data Report, Canyon Tunnel, South San Joaquin Irrigation District, updated November 4, 2022. The following is a brief summary of pertinent site geologic information related to evaluating the tunnel alignment.

The prominent regional geologic feature of the project site is the sequence of sedimentary and volcanic flow deposits of the Mehrten Formation, which are typically capped by the volcanic flows of Table Mountain Latite. The Mehrten rock units were deposited as channel fill along an ancestral river channel that traversed approximately along the alignment of the present-day Stanislaus River. In the project area, the ancestral river eroded into the regional basement rock (the Gopher Ridge Formation), which the channel fill nonconformably overlies. The present-day Stanislaus River has eroded a canyon through the volcanic cap and channel fill deposits that exposes the complete geologic section in the project area. The ancient channel maximum depth appears to be approximately 100-150 feet lower than the present-day channel.

Mehrten Formation sedimentary and volcanic rocks are well exposed in un-lined portions of tunnels and canals in the general area. The engineering characteristics of the different facies within the formation vary. In general, the rock is typically weak, often does not stand well, and is generally subject to erosion by flowing water. The upper member of the Mehrten Formation in the project area is known as the Table Mountain Latite, comprised of a series of volcanic lava flows. The thickness of the latite flows that cap the channel fill in the project area ranges from nil to over 100 feet thick. The contact zone between the latite and the underlying Mehrten Formation sedimentary rocks, which was exposed during the excavation of the nearby OID Webb Tunnel, is generally poor tunneling ground; however, we do not anticipate that the contact zone will be encountered along the proposed Canyon Tunnel alignment.

The regional basement rock, the Gopher Ridge Formation, generally consists of a fine-grained metavolcanic rock unit that is colloquially referred to as “greenstone”. Fresh, unweathered metavolcanic rock is exposed along nearby OID South Main Canal Tunnels 1 through 6, which are unlined or partially lined. The fresh to slightly weathered rock is typically very strong and hard to extremely hard. Moderately to highly weathered zones with weak and moderately soft rock commonly occur near the contact with the overlying Mehrten Formation channel fill. An approximately 250-foot wide, E-W-trending mineralization zone of iron sulfide-rich rock occurs within the formation. The zone is exposed along the JSC and is roughly centered around the Copper Tunnel.

We evaluated multiple potential tunnel alignments between the potential upstream portal locations (near Goodwin Dam) and the downstream portal location. The results of the geologic mapping and rock core drilling indicate that a “bedrock high” in the Gopher Ridge Formation metamorphic basement rock unit coincides with the central portion of this tunnel alignment. The bedrock high represents the southeastern margin of an ancestral river channel that was infilled with Mehrten Formation sedimentary and volcanic rocks. We identified a tunnel alignment that traverses around the bedrock high to the northwest as the preferred tunnel alignment, as detailed in Section 2.3.1.

Owing to the extremely limited access to the upstream portal areas, P&P assumes that tunnel construction will proceed upstream from the downstream portal. Our site investigation data indicates that weathered to fresh metavolcanic rock of the Gopher Ridge Formation will be encountered during excavation of the downstream portal staging area and along the downstream-most 800 linear feet of the tunnel alignment (approx. tunnel Sta. 120+12 to 112+00). P&P anticipates that the ground conditions in the Gopher Ridge Formation will be generally good for tunneling and will consist of hard to very hard, strong rock that will require hard rock excavation methods, including drill-and-blast. Spot rock dowels may be required to stabilize rock blocks in localized fracture zones.

In general, the uppermost 5 to 20 feet of the Gopher Ridge Formation metavolcanic rock (nearest the contact zone with the overlying Mehrten Formation) is moderately to highly weathered; the subsurface investigation results indicate that much of the central and downstream portions of the tunnel will be excavated near the contact zone, as depicted in the tunnel geologic profile on Sheet 1.1 of the 60 Percent Design Drawings included in Appendix B. The Gopher Ridge Formation is generally softer and weaker in this zone and potentially unstable during excavation, especially immediately below the contact zone with the overlying Mehrten Formation.

As detailed above and in Section 2.3.1, the tunnel alignment traverses around a known bedrock high near the center of the alignment. Owing to the uncertainty of the extent of the bedrock high

at tunnel elevation, P&P anticipates that “mixed-face” conditions of Mehrten Formation sedimentary rocks overlying weathered Gopher Ridge Formation metavolcanic rock may be encountered in this area (between approximate Tunnel Sta. 68+00 to 51+00). Localized zones of poor ground may be encountered along this reach of the tunnel owing to the weathered nature of the rocks near the contact.

P&P anticipates that mixed-face conditions similar to those described above may be encountered along the tunnel alignment near the upstream portal, regardless of which portal alternate is selected. The results of our geologic mapping and rock core drilling work indicate that the north abutment of Goodwin Dam was constructed against Gopher Ridge Formation bedrock and the contact between the Mehrten Formation and Gopher Ridge Formation occurs just above the elevation of the existing JSC near the dam. The contact dips gently (approximately 10 to 20 degrees) to the west-northwest, roughly parallel to the tunnel alignment. We anticipate that the upstream-most 200 linear feet (approximate) of the tunnel alignment will be constructed along or just below the contact zone.

The geologic conditions along most of the tunnel alignment will predominantly consist of the various sedimentary and volcanic facies of the Mehrten Formation, as described above. Based on the subsurface investigation results and our team’s observations during construction of the nearby Webb Tunnel, P&P anticipates that the ground conditions will be generally favorable for tunneling except for potentially slow-raveling, loose sandstone beds that may slow production and require temporary support installation. We anticipate that the raveling ground will occur in localized areas across less than 10 percent of the total tunnel alignment.

Under our work scope, we installed groundwater-monitoring instrumentation in the exploration core hole borings. Based on our initial findings (refer to the Geologic Data Report, dated November 4, 2022), our team’s experience during construction of the nearby Webb Tunnel and construction reports from the nearby Goodwin Tunnel, we anticipate that little groundwater will be encountered during most of the tunnel construction and that production rates will not be significantly affected by groundwater. Along the upstream reach of the tunnel near Goodwin Reservoir, however, there is a potential for significant inflows. We understand the nearby Goodwin Tunnel encountered approximately 180 gpm water inflows within the Mehrten Formation at a location within a few hundred feet from the Goodwin Reservoir.

The following sections include our rationale and recommendations related to the proposed tunnel alignment, upstream portal alternates, and construction means and methods.

2.3 RECOMMENDATIONS

2.3.1 Tunnel Alignment

Based on the previous hazard assessment work during the 2018 Phase 2 Report update, the most hazardous portion of the JSC extends from the existing canal headgates at Goodwin Dam (canal Sta. 0+00) to just upstream of the canal access ramp at approx. canal Sta. 122+00. We recommend that the bypass tunnel extend from near Goodwin Dam to near the canal access ramp.

Our team evaluated numerous potential tunnel alignments during our 30- and 60 Percent Design investigations. The prominent geologic feature along the potential tunnel alignments between the proposed portal locations is the bedrock high in the Gopher Ridge Formation metamorphic

basement rock unit that occurs northwest of the existing Ram Tunnel (in the central portion of the proposed tunnel alignment area). The bedrock high defines the margin of the ancestral river channel in which the Mehrten Formation sedimentary and volcanic rocks were deposited.

The subsurface investigation focused on defining the northwest extent of the bedrock high at the elevation of the proposed tunnel. The results of our investigation indicate that the geologic conditions along the majority of the proposed tunnel alignment consist of the channel fill deposits (Mehrten Formation), including upstream and downstream of the bedrock high feature. Owing to the likely complications and decreased production rates that would be experienced by constructing the central portion of the tunnel through the less weathered metamorphic basement rock, P&P recommends that the tunnel alignment traverse northwest of the area where we interpret the bedrock high occurs at the elevation of the proposed tunnel. The tunnel length along this alignment is a maximum of 12,012 linear feet depending upon the desired location of the upstream portal, which is discussed in Section 2.3.2.

Our interpretation of the subsurface ground conditions is based on the geologic mapping, rock core drilling and geophysical survey work performed to date. Many of the rock core hole locations are several hundred feet (horizontally) from one another, and several of the rock core holes project up to a few hundred feet (horizontally) from the proposed tunnel alignment. Our interpretation of the ground conditions between the rock core holes is based primarily on the geophysical survey data. The results of the subsurface investigation are detailed in the November 4, 2022 Geologic Data Report. P&P concludes that performing additional subsurface exploration for evaluation of rock types along the tunnel alignment is not necessary. Groundwater conditions along the alignment, however, warrant additional investigation to evaluate potential groundwater inflow during construction and potential seepage out of the tunnel during future water conveyance operations.

2.3.2 Upstream Portal Alternates

Our team evaluated two primary locations/configurations for the Canyon Tunnel upstream portal. The locations (Alternate 1 and Alternate 2) are illustrated on Sheets 2.0 and 2.1 in the 60 Percent Design Drawings included in Appendix B. Each portal alternative is located within the vicinity of the north abutment of Goodwin Dam; Goodwin Dam is operated by Tri-Dam Project (TDP).

We identified potential significant rock fall hazards along the vertical cliffs immediately above the north abutment of Goodwin Dam, as described in our November 4, 2022 Geologic Hazards Study (Appendix A). P&P recommends that the new upstream portal and associated facilities should be designed to withstand a rock fall event and reduce the potential for associated water delivery disruptions.

Upstream portal Alternate 1 is located within the existing “forebay” immediately upstream of Goodwin Dam where water is diverted into the JSC. As-Built documentation for the existing forebay structure provided by SSJID and data from our preliminary field reconnaissance indicate that the forebay is a concrete-lined, box-shaped structure with interior concrete buttress walls designed to divert water flow to the headgates of the JSC. Water diversion is controlled via multiple gates located at the downstream end of the forebay structure. Goodwin Dam is a spill-over concrete-arch dam structure; a secondary spillway channel within the headworks of the JSC provides a mechanism to lower the reservoir level in Goodwin Reservoir below the crest level. A second set of JSC gates are located immediately downstream of the JSC headworks.

The upstream portal Alternate 1 would be a “submerged” intake – i.e., the tunnel inlet gates would be below the typical elevation of the reservoir level, as illustrated in the conceptual portal section on Sheet 5.02 in the 60 Percent Design Drawings included in Appendix B. The advantages of upstream portal Alternate 1 include:

- Reduced tunnel dimensions and reduced unit price for tunnel excavation and support, owing to the increased invert grade drop along the tunnel alignment (as described in Section 2.2.1)
- The ability to utilize the existing forebay structure as the foundation for a new reinforced concrete cap designed to protect the tunnel from rock fall debris
- Replacement of the existing canal headgates (which are exposed to potential damage from rock fall debris) with new gates (similar operations as existing) located beneath the new reinforced concrete protective structure (Alternate 1A on Sheet 5.0) or at the downstream portal (Alternate 1B on Sheets 5.1 and 5.1.1)
- Permanent access to the north abutment of Goodwin Dam via a new barge system

The disadvantages of Alternate 1A include the potential for additional agency oversight (owing to the work that would occur within Goodwin Reservoir) and increased construction costs relative to Alternate 2A, which are discussed in our updated construction cost estimate detailed in Section 3.0. Alternate 1B would allow better access to the control gates at the downstream portal but would also require upstream stop logs and would include a less-favorable pressurized tunnel as opposed to more-favorable open channel flow. Our current design does not consider permanent facilities beyond what would be required for water diversion into the new tunnel; additional permanent facilities may include other improvements that may be required by regulatory agencies or desired by the Owner. Such issues would be considered during subsequent design phases should SSJID chose to continue pursuing upstream portal Alternates 1A, 1B and some aspects of 2B.

Upstream portal Alternates 2A and 2B are located within the existing JSC approximately 100 feet downstream of the existing JSC headgate structure. Our preliminary design of portal Alternate 2 includes a reinforced shotcrete shoring wall and a concrete-lined canal plug downstream of the new portal to divert water flows into the new tunnel (refer to Sheet 2.1). The advantages of Alternate 2A include lower upstream facilities construction costs and avoidance of some potential access and environmental issues, but the primary disadvantage of Alternate 2A is the exposure to rock fall hazards from the rock cliffs immediately above this portion of the canal. If portal Alternate 2 were selected, P&P recommends that rock fall mitigation measures be considered (some or all of those included in Alternate 2B shown on Sheet 5.3). Mitigation measures may include protective barriers at the toe of the slope above the new portal and existing JSC headworks or new reinforced concrete protection structures. For both Alternates 2A and 2B, we suggest that the existing JSC gates would remain (refer to Sheets 5.2 and 5.3). For Alternate 2A, permanent access to the north abutment of Goodwin Dam would be via the tunnel; for Alternate 2B, permanent access to the north abutment would be via the proposed barge system.

The two upstream portal alternates are presented in our updated construction cost estimate in Section 3.0. It should be noted that the current design for each of the alternates is conceptual in nature.

SSJID opted to pursue the CEQA permitting phase to determine if Alternate 1A would be feasible. The primary concern with this Alternative was the possibility of a fish screen requirement that has since been determined not to be required. P&P therefore recommends Alternate 1A for final design of the upstream portal based on more favorable risk reduction.

2.3.3 Downstream Facilities

Temporary downstream facilities to support construction include a temporary construction laydown yard and excavation spoils and staging areas, as shown on Sheets 0.4 and 3.0.

Permanent downstream facilities will include an access ramp, shotcrete facing of inclined rock cuts below the high-water line, permanent shotcrete shoring of vertical cuts, permanent unsupported cut slopes, a short section of new canal with water flow gauging, concrete paving, fencing and a plug/ramp in the existing canal; refer to Sheet 3.1 for details.

2.3.4 Tunnel Construction Methods

Numerous considerations must be factored into tunnel construction methodology and equipment. Key considerations include tunnel dimensions, tunnel length, tunnel support requirements, location and access to the work area, project schedule requirements, and (perhaps most importantly) ground and groundwater conditions. Based on our evaluation of the site conditions, project components, and our previous tunnel design and construction experience, Our team evaluated two primary tunnel construction methods for the current project: conventional and tunnel boring machine (TBM).

TBM's are typically a viable construction method for tunnels longer than approximately 5,000 feet. Therefore, the use of a TBM is considered a feasible option for the current tunnel project by virtue of tunnel length. TBM's cost much more than conventional mining equipment, but production (i.e. tunnel advance) rates are typically much higher than conventional methods. The difference in production rates typically increases as tunnel section dimensions increase; the dimensions of the proposed Canyon Tunnel are relatively small, so conventional excavation methods are also a viable option for tunnel construction.

Conventional methods encompass numerous techniques and various styles of tunneling equipment. For the purposes of the Canyon Tunnel, we evaluated mechanical mining methods consisting of a roadheader and/or an excavator with a boom-mounted cutting head/impact hammer as viable options for tunnel excavation in weak to moderately strong rock and blasting in strong to very strong rock. A key consideration when evaluating conventional mining options is the removal of tunnel spoils ("muck") during tunnel advance (i.e. "mucking"). Roadheaders are capable of continuous muck removal as tunnel excavation progresses via the use of conveyers that translate the muck behind the machine to be deposited into haul trucks or muck cars (if temporary rail transport is employed). If an excavator is employed for tunnel excavation, the use of a secondary vehicle for muck removal ahead of the excavator is required, which significantly impacts tunnel production rate. Owing to the relatively long length and small dimensions of the Canyon Tunnel, P&P anticipates that a roadheader, supplemented by drilling and blasting as needed, will be the preferred conventional excavation method.

Owing to the extremely limited access to the upstream portal area (regardless of the selected upstream portal alternate), P&P assumes that the tunnel will be excavated in the upstream direction from the downstream portal. The results of the subsurface investigation indicate that the

geologic conditions at the downstream portal and along the downstream portion of the tunnel consist of hard, strong metamorphic basement rock of the Gopher Ridge Formation with a uniaxial compressive strength (UCS) of up to approximately 19,000 pounds per square inch (psi). The hard, strong rock will be encountered for up to approximately 800 linear feet along the downstream-most portion of the tunnel. Based on the strength of the rock and the length of tunnel along which it will likely be encountered, P&P assumes that the downstream portion of the tunnel will likely be constructed using drill-and-blast methods. This portion of the tunnel may be excavated prior to mobilization of the primary tunneling equipment.

As discussed in Section 2.2.2, the ground conditions along the remaining approximately 10,500+ linear feet of the tunnel alignment mostly consist of the sedimentary and volcanic rocks of the Mehrten Formation (except for localized mixed-face conditions and near the upstream portal). Based on our team's previous tunnel construction experience on nearby tunnel projects (including the Webb Tunnel) and the subsurface data gathered from the Canyon Tunnel site, we anticipate that the strength, hardness, and cohesion of the various Mehrten lithologies will be highly variable. The Mehrten Formation consists of interbedded sandstones, conglomerates and pyroclastic rock.

The distance that the tunnel can be advanced without permanent support will be a function of the length of time that the ground can remain unsupported, commonly referred to as "stand-up time". We estimate that the entire tunnel may be excavated and supported with an initial shotcrete layer prior to final support installation. We also estimate that several reaches of very weak, slowly raveling ground will be encountered throughout the tunnel that will require immediate support. Our preliminary design of the permanent tunnel support consists of a 4-inch-thick, fiber-reinforced shotcrete liner across the arch and a 6-inch-thick concrete invert slab. Installation of these permanent tunnel support elements is feasible for both conventional and TBM options.

Several key considerations must be factored into TBM design and feasibility for the current tunnel. The TBM cutter head design must be capable of advancing through rock types of vastly different characteristics. For example, substantial zones of very weak, soft rock are likely to be encountered along various reaches within the Mehrten Formation. The very weak rock, as well as the relatively weak sandstone is considered not sufficiently strong to reliably provide enough bearing and friction for the gripper pads to efficiently thrust the TBM and advance the tunnel. Therefore, the use of partial, pre-cast concrete segment liners, which serve as surfaces to provide adequate TBM thrust but often come at substantial cost, will likely be required. SSJID has requested that the finished tunnel contain a flat concrete invert to allow passage of maintenance trucks and equipment. Pre-cast, invert-only segments are available that would serve both purposes.

Roadheaders and TBM's are run by electric motors. Owing to the remote nature of the site, P&P estimates that on-site diesel generators with appropriate power output and support infrastructure will be utilized. Alternatively, a contractor may opt to drop power from the existing power transmission lines located approximately ½-mile west of the downstream portal. For the purposes of the current design, P&P anticipates that any new power transmission lines installed near the downstream portal would be temporary (for construction only) and not remain for future use, unless desired by the landowners or SSJID.

Based on discussions with our specialty tunneling consultants, P&P estimates that the use of a TBM on the Canyon Tunnel would expose SSJID to unnecessary contractual risk. Owing to the anticipated ground conditions, the potential risk posed using a TBM on the Canyon Tunnel

outweighs the potential benefits (faster production rate, relatively low labor costs). The difficulties associated with variable ground conditions – including mixed-face conditions, zones with large, hard boulders supported by relatively weak sand – increases the risk of a TBM being unable to advance or require significant reinforcement to provide forward thrust. Such situations may be cause for a potentially costly differing site conditions claim by the contractor.

A TBM was utilized for construction of the nearby Stockton East Water District (SEWD) Goodwin Tunnel, which was constructed in the late 1980's. The ground conditions along the tunnel alignment largely consisted of hard rock of the Gopher Ridge Formation in which the TBM performed well. However, an “underground river” was encountered along the tunnel alignment near Goodwin Dam that precluded TBM advance, as described in the construction documentation for Goodwin Tunnel that was obtained by our team. The ground conditions in this area likely consisted of interbedded relatively weak sandstone and conglomerate, which P&P anticipates will be encountered along the Canyon Tunnel alignment. We understand the situation at the Goodwin Tunnel resulted in a significant claim by the contractor that ultimately dramatically increased the cost of the tunnel.

TBM technology has improved since the construction of the Goodwin Tunnel. It is likely that a modern TBM could handle the varying ground conditions that are anticipated along the Canyon Tunnel; however, as noted above, the use of a TBM increases the risk to owner and P&P recommends that the use of a TBM not be considered for the current tunnel project. Our updated construction cost estimate indicates that bid prices for conventional tunneling will be less than bids that assume the use of a TBM (refer to the various assumptions described in Section 3.2). Additionally, we estimate that a roadheader is better suited for the varying and mixed-faced ground conditions that are likely to be encountered along the tunnel alignment and SSJID would be exposed to significantly less risk of contractor claims during construction.

3.0 PRELIMINARY CONSTRUCTION COST ESTIMATE

3.1 APPROACH

The Preliminary Engineer's Opinion of Probable Construction Cost Estimate (CCE) presented herein is mostly based on an estimated labor and materials approach for the tunnel and portal excavation and support elements, rather than a typical unit price approach (e.g. cost per linear foot). A unit price approach was used for estimating access barge and inlet/outlet control structure elements. Our detailed estimate is included in Appendix D and includes labor and materials costs, contractor overhead and profit. Engineering design, land entitlement (including Right-of-Way acquisition), contractor bidding support, and construction management and inspection services are not included in the current CCE estimate but are provided in Section 4 of this report.

For the tunneling estimates, labor rates, equipment rates and materials costs are based on the work and experience of our cost estimator, a retired heavy construction/tunnel contractor vice president. The presented CCE includes and is based on the following:

- The 2021 union/prevaling wage labor rates as published by the State of California for Calaveras County for Laborers and Operating Engineers, including worker's compensation and payroll taxes
- Tunneling equipment and materials procurement/rental rates are based on quotations from various suppliers

- Equipment operating rates compared to contractors’ rates, based on the experience of the estimator
- Concrete/shotcrete material prices are based on quotations from local suppliers
- A cost escalation schedule of approximately 7 percent per annum is included as a separate line item in the CCE; our estimator based the potential construction schedule and cost escalation on a Notice-to-Proceed date in early 2025
- A budget contingency is also included as a separate line item in the CCE to cover various current uncertainties related to design and construction
- Additional assumptions are described in Appendix D.

3.2 CONSTRUCTION COST SUMMARY

The backup documentation, compiled by our cost estimators, is included in Appendix D. A summary of the CCE for the use of a roadheader (Table 2) and TBM (Table 3) is as follows:

TABLE 2
Engineer's Estimate of Probable Construction Costs
Roadheader

Activity	RH Alt 1A	RH Alt 1B	RH Alt 2A	RH Alt 2B
Mob/demob	\$501,344	\$501,344	\$501,344	\$501,344
Portals/Turn-under	\$1,730,640	\$1,730,640	\$1,730,640	\$1,730,640
Excavate Tunnel	\$10,132,275	\$10,132,275	\$11,128,189	\$11,128,189
Muck haul off site	\$2,711,593	\$2,711,593	\$3,126,679	\$3,126,679
Shotcrete Tunnel Lining	\$2,614,034	\$2,614,034	\$2,899,340	\$2,899,340
Invert (cast in place)	\$1,755,207	\$1,755,207	\$1,891,318	\$1,891,318
Connection Channels/Diversion Walls	\$202,889	\$202,889	\$383,028	\$383,028
Barge Access	\$630,000	\$630,000	\$ -	\$630,000
Overhead/Equipment Rental	\$10,512,066	\$10,512,066	\$10,919,399	\$10,919,399
Landowner Items (Well, Waterline, Fence)	\$300,000	\$300,000	\$300,000	\$300,000
15% Profit	\$4,663,507	\$4,663,507	\$4,931,990	\$5,026,490
Inlet/Outlet Control Structures	\$3,755,000	\$5,004,000	\$215,000	\$5,976,000
Subtotal	\$39,508,555	\$40,757,555	\$38,026,927	\$44,512,427
Cost Escalation – 7% per annum (4 years)	\$11,062,395	\$11,412,115	\$10,647,540	\$12,463,480
Contingency – 10%	\$3,950,855	\$4,075,755	\$3,802,693	\$4,451,243
Total	\$54,521,805	\$56,245,425	\$52,477,159	\$61,427,149

TABLE 3
Engineer's Estimate of Probable Construction Costs
Tunnel Boring Machine

Activity	TBM Alt 1A	TBM Alt 1B	TBM Alt 2A	TBM Alt 2B
Mob/demob	\$501,344	\$501,344	\$501,344	\$501,344
Portals/Turn-under	\$1,730,640	\$1,730,640	\$1,730,640	\$1,730,640
Excavate Tunnel	\$8,395,762	\$8,395,762	\$7,200,514	\$7,200,514
Muck haul off site	\$4,029,606	\$4,029,606	\$3,972,825	\$3,972,825
Shotcrete Tunnel Lining	\$3,532,577	\$3,532,577	\$3,512,203	\$3,512,203
Invert (pre-cast segments)	\$4,567,333	\$4,567,333	\$4,497,550	\$4,497,550
Connection Channels/Diversion Walls	\$202,889	\$202,889	\$202,889	\$202,889
Barge Access	\$630,000	\$630,000	\$ -	\$630,000
Overhead/Equipment Rental	\$18,767,054	\$18,767,054	\$18,501,354	\$18,501,354
Landowner Items (Well, Waterline, Fence)	\$300,000	\$300,000	\$300,000	\$300,000
15% Profit	\$6,398,581	\$6,398,581	\$6,062,898	\$6,157,398
Inlet/Outlet Control Structures	\$3,755,000	\$5,004,000	\$215,000	\$5,796,000
Subtotal	\$52,810,786	\$54,059,786	\$46,697,216	\$53,002,716
Cost Escalation – 7% per annum (4 years)	\$14,787,020	\$15,136,740	\$13,075,220	\$14,840,760
Contingency – 15%	\$7,921,618	\$8,108,968	\$7,004,582	\$7,950,407
Total	\$75,519,424	\$77,305,494	\$66,777,019	\$75,793,884

The cost summaries detailed above are considered conservative with respect to equipment costs. The cost summaries include rental costs for a roadheader and TBM, respectively. Contractors that own the proper equipment may provide lower bid prices for these line items.

Cost escalation is included in the estimates. Based on the California Construction Cost Index (CCCI) data, the cost escalation between May 2017 and October 2022 is 35 percent, or approximately 7 percent annually.

4.0 PROJECT SCHEDULE AND SOFT COSTS

As mentioned in Section 3, P&P estimates that the project construction Notice-to-Proceed could be issued in 2025. Our estimated duration of construction included in Appendix D is approximately 36 months using Alternate 1A and the conventional tunneling method.

To substantiate the estimated 2025 construction start date, we have evaluated the potential schedule for the remaining work to be completed prior to tunnel construction. Our evaluation is based on our work on previous projects, including the nearby Webb Tunnel Project. Note that the schedule is considered reasonably optimistic and assumes no significant delays, especially as could be related to land entitlement. We understand that land entitlement and other related work should proceed relatively soon; these items are not included in P&P's work scope.

Discussion and potential schedule of each of the remaining engineering, permitting and land entitlement work items is included in the following subsections. An itemized summary of the estimated schedule and approximate soft costs of the remaining work is included in Section 4.5.

4.1 ENGINEERING, DESIGN AND PRE-CONSTRUCTION

The remaining phases of engineering and design, and the estimated schedule of completion of each phase is as follows:

- 60 Percent Engineering and Design – completion: November 2022
- 90 Percent Design and Contract Documents – estimated completion: October 2023
- 100 Percent Design and Contract Documents – estimated completion: June 2024
- Pre-Construction and Contractor Bidding Support – estimated bid date: Fall 2024

P&P will provide a Proposal and Fee Estimate for the 90 Percent Engineering and Design phase under separate cover.

Contract Documents, including the Geologic Data Report and the Geotechnical Baseline Report, will be updated and finalized during the 90 and 100 Percent Design phases. P&P will also provide updated Contract Drawings and Technical Specifications during these phases. Upon completing the 100 Percent Design phase, P&P will provide SSJID with Contract Drawings, Documents and Technical Specifications that will be used to solicit bids from qualified tunneling contractors. Based on past experience, we anticipate that the bidding process will require approximately 6 months to complete, including time for anticipated contractor prequalification, bid walks at the site, review of contractor questions, and bid evaluation/award.

4.2 CALIFORNIA ENVIRONMENTAL QUALITY ACT PERMITTING AND MONITORING

Background studies, including biological and cultural resources site evaluations in relation to California Environmental Quality Act (CEQA) permitting and approval, have begun and are nearly complete. We understand most of the environmental monitoring and mitigation work will be required at the downstream portal and laydown areas. There will also be monitoring required at the upstream inlet for the Alternate 1 owing to the proximity of the Stanislaus River and required mitigations for permitting.

Implementation of mitigation measures will likely need to begin prior to contractor mobilization. The mitigation measures will also need to be monitored and preserved during tunnel construction. The estimated costs associated with additional CEQA permitting and monitoring are included in our 90% Proposal.

4.3 LAND ENTITLEMENT

The location and dimensions of the tunnel alignment and portal areas are included in the 60 Percent Design. The 60 Percent Design Drawings illustrate the locations of the permanent SSJID facilities that will require Right-of-Way (ROW) for land entitlement purposes. We understand that the proposed tunnel alignment is located on two privately owned parcels. We understand SSJID will negotiate the cost per acre of the land entitlement with each landowner prior to tunnel construction.

We assume the ROW will encompass a 100-foot-wide (verify) area along the entire tunnel alignment centered on the centerline of the tunnel. The costs associated with land entitlement are unknown at this time. Also the cost of the temporary easements for the construction laydown and staging areas are unknown at this time.

4.4 CONSTRUCTION MANAGEMENT AND INSPECTION

As described in Section 3.1, the current CCE assumes a Notice-to-Proceed date of 2025 for tunnel construction, which we currently believe to be a reasonably optimistic date based on the remaining work described herein. The costs associated with Construction Management and Inspection Services are largely dependent on the overall construction duration, which is currently estimated at approximately 36 months. Based on our experience during similar projects, we herein estimate that the costs associated with Construction Management and Inspection services is approximately 10 percent of the construction cost.

4.5 TOTAL PROJECT SOFT COSTS AND SCHEDULE

A summary of the projected schedule of project costs described above is as follows in Table 4:

**TABLE 4
 Engineer's Estimate Project Soft Costs and Schedule – Update**

Projected Completion Date	Description	Estimated Cost
January – October 2023	90 Percent Design (incl 10% contingency)	\$902,000
	CEQA and Permitting	\$65,000
	Land Entitlement	TBD
December 2023 – June 2024	100 Percent Design	\$90,000
	CEQA and Permitting	\$10,000
	Land Entitlement Completion	TBD
July – December 2024	Bidding Support	\$72,000
Spring 2028	Construction Management and Inspection	\$5,170,000
	CEQA Monitoring and Compliance	\$471,000
	Temporary Construction Easement	TBD
	Total	\$6,780,000

5.0 LIMITATIONS

The data, results of engineering evaluation, and referenced documents are for project planning and budgeting purposes for SSJID’s proposed Canyon Tunnel project. The preliminary design is based on our understanding of SSJID needs, site observations and exploration data. Our report does not reflect potential variations in client needs or subsurface conditions.

P&P should review any substantial future deviation from the assumptions or project description contained in this report and should provide additional recommendations, as needed.

SSJID should understand that P&P cannot control other consultants involved in the project or the specific decisions of government agencies. In addition, P&P does not have a contractor’s experience with factors such as: the means, methods, sequences, and operations of construction and related safety programs; the full cost and extent of labor, equipment, and materials; contractors’ techniques for determining prices and market conditions; and other factors that contractors consider and over which P&P has no control. Given the various assumptions P&P

has made to develop an opinion of probable construction costs, P&P's CCE will deviate from bids furnished by contractors. It should be noted that our CCE should not be regarded as a guaranteed maximum, and that uncertain annual price escalation will likely occur.

This report was prepared in accordance with the generally accepted standards of engineering geologic and civil/geotechnical engineering practice that exist in Calaveras County at the time the report was written. No other warranty, express or implied, is made.

It should be noted that changes in the standards of practice in the fields of engineering geology and civil/geotechnical engineering, changes in site conditions, new agency regulations, or modifications to the proposed project are grounds for this report and companion documents to be professionally reviewed. In light of this, there is a practical limit to the use of this report without critical professional review. It is suggested that 3 years be considered a reasonable time for the use of this report without critical review.

6.0 CLOSURE

Please contact us if you have any questions.

Prepared by,
Provost & Pritchard Consulting Group

Andrew S. Kositsky, GE No. 2532
Principal Engineer

Scott W. Lewis, CEG No. 1835
Principal Tunneling Consultant

BOARD AGENDA REPORT

Date: 11/17/2022
Staff: Brandon Nakagawa

SUBJECT: 1988 Agreement Conservation Accounting

RECOMMENDED ACTION: Discussion Item Only—No action to be taken.

BACKGROUND AND/OR HISTORY:

This item will be presented at the meeting.

Board Motion:

Motion by: _____ **Second by:** _____

VOTE:

OID: DeBoer (Yes/No) Doornenbal (Yes/No) Orvis (Yes/No) Santos (Yes/No) Tobias (Yes/No)

SSJID: Holbrook (Yes/No) Holmes (Yes/No) Kamper (Yes/No) Spyksma (Yes/No) Weststeyn (Yes/No)

BOARD AGENDA REPORT

Date: November 17, 2022

Staff: Jeff Shields

SUBJECT: POWER PURCHASE AGREEMENT

RECOMMENDED ACTION: Discussion Item Only—No action to be taken.

BACKGROUND AND/OR HISTORY:

The Power Purchase Agreement process is ongoing, and moving forward as envisioned. Negotiations continue with the evaluation of options an integral part of this process.

A conference call is scheduled for November 8, 2022, regarding the current status and options for presentation, review and action by the Board of Directors in December. A complete update will be provided at the meeting of November 17, 2022.

Board Motion:

Motion by: _____ **Second by:** _____

VOTE:

OID: DeBoer (Yes/No) Doornenbal (Yes/No) Orvis (Yes/No) Santos (Yes/No) Tobias (Yes/No)

SSJID: Holbrook (Yes/No) Holmes (Yes/No) Kamper (Yes/No) Spyksma (Yes/No) Weststeyn (Yes/No)

BOARD AGENDA REPORT

Date: 11/17/2022
Staff: Jeff Shields
Sharon Cisneros

SUBJECT: 2023 Draft Budget

RECOMMENDED ACTION: Discussion Item Only—No action to be taken.

BACKGROUND AND/OR HISTORY:

This item will be presented at the meeting.

Board Motion:

Motion by: _____ **Second by:** _____

VOTE:

OID: DeBoer (Yes/No) Doornenbal (Yes/No) Orvis (Yes/No) Santos (Yes/No) Tobias (Yes/No)

SSJID: Holbrook (Yes/No) Holmes (Yes/No) Kamper (Yes/No) Spyksma (Yes/No) Weststeyn (Yes/No)

GENERAL MANAGER'S REPORT
TRI-DAM PROJECT
of the
Oakdale & South San Joaquin Irrigation Districts
Board of Directors Meeting
November 17, 2022

Project Activities

- This is a difficult week at Tri-Dam as it is shortened by two days. The office will be closed under the regular schedule on Friday and so the actual Veterans Day holiday will be Thursday. This is the week of the month we need to get the Board packets organized and distributed. And then, to complicate things more, it started snowing early Monday morning and by 2PM there was 6-8" accumulated in the yard. It is supposed to snow throughout the night and potentially into Wednesday. Of course, we need the snow so we will just have to get the Board packets out one way or another.

- I have four personnel matters for closed session which also complicated the Board packet process. Additionally, OID has completed the solicitation packet for the Finance Manager position and that is now posted on social media sites as well as the District's and Tri-Dam web sites. We are advancing the PPA negotiations with the successful bidder in a conference call tomorrow (Tuesday) afternoon I will have a report on the status of the winning bid and terms available at the Board meeting.

OPERATIONS AND MAINTENANCE MANAGER BOARD REPORT

Chris Tuggle
Nov 17, 2022

OPERATIONS:

Reservoir Data (A/F):

FACILITY	STORAGE	MONTH CHANGE
Donnells	42,459	(643)
Beardsley	70,501	(633)
Tulloch	56,246	(4,383)
New Melones	583,669	(35,381)

Outages:

Plant	Dates	Duration	Cause
--------------	--------------	-----------------	--------------

Operations Report:

New Melones Inflows:

Total inflows for water year 22/23 as of October 31: 18,516 A/F.

District Usage:

Total District usage for the water year 22/23 as of October 31: 23,620 A/F.

Precipitation:

Total precipitation for the month of October was .02 inches.

Other Activities:

- Completed irrigation season
- FERC Part 12D PFMA review with McMillan Jacobs
- Lead Operator attended WECC conference
- Generator clearances for both Beardsley and Sandbar Powerhouses
- Conducted inspection and daily checks at all facilities

MAINTENANCE:

Donnell:

1. Equipment in service.

Beardsley:

1. Annual Maintenance

Sandbar:

1. Annual Maintenance

Tulloch:

1. Equipment in service.

Misc.:

- Beardsley Annual Maintenance
 - Switchyard Maintenance
 - PRV Repair
 - Diffuser repaired
 - Valve transported to contractors' facility for repairs
 - Governor Upgrade
 - Plumbing and spool work complete
 - HMI Installed
 - Rewire in progress
 - Wicket gate lock repaired
 - Miscellaneous maintenance (filter, electrical inspections, trip test, etc.)
- Sandbar Annual Maintenance
 - Switchyard Maintenance
 - Cooling water lines
 - Miscellaneous maintenance (filter, electrical inspections, trip test, etc.)
 - Clear the access roads for the 115kV pole repairs
- Winterized the Donnell's Cottage

BEARDSLEY PRECIPITATION

YEAR	JUL	AUG	SEPT	OCT	NOV	DEC	JAN	FEB	MAR	APR	MAY	JUNE	TOTAL
1958-59	0.00	0.00	0.00	0.00	0.00	0.00	0.00	7.40	1.39	1.40	1.04	0.00	11.23
1959-60	0.00	0.03	3.09	0.00	0.00	1.92	5.74	8.38	4.68	2.45	0.35	0.00	26.64
1960-61	0.05	0.00	0.44	0.63	5.33	2.43	1.60	3.04	4.96	1.49	1.84	0.29	22.10
1961-62	0.21	1.12	0.77	0.70	3.39	2.98	2.04	15.32	6.13	1.12	1.04	0.02	34.84
1962-63	0.30	0.16	0.35	2.98	1.05	2.66	5.91	8.37	6.08	8.24	3.70	0.74	40.54
1963-64	0.00	0.44	0.59	2.63	7.81	0.81	5.84	0.21	3.02	2.01	2.44	1.64	27.44
1964-65	0.00	0.00	0.34	2.08	7.40	17.93	5.90	1.34	2.44	5.27	0.32	0.29	43.31
1965-66	0.00	1.47	0.60	0.47	12.38	4.59	1.68	2.33	1.00	2.39	0.43	0.10	27.44
1966-67	0.13	0.00	0.28	0.00	7.55	8.48	8.77	0.67	10.02	10.25	2.04	1.05	49.24
1967-68	0.00	0.39	0.90	0.54	2.47	3.35	4.94	4.81	3.48	0.73	1.44	0.02	23.07
1968-69	0.10	0.65	0.00	2.12	6.22	8.28	19.45	8.35	1.88	3.39	0.21	0.39	51.04
1969-70	0.00	0.00	0.55	3.41	2.98	6.46	17.06	3.11	3.43	2.50	0.00	3.17	42.67
1970-71	0.00	0.00	0.00	0.91	10.71	8.44	2.83	1.16	4.87	1.49	1.80	0.77	32.98
1971-72	0.00	0.02	0.29	1.22	6.22	10.31	2.39	2.78	1.01	4.03	0.10	1.62	29.99
1972-73	0.00	0.58	0.17	1.85	6.27	5.57	12.08	12.06	5.31	1.11	0.72	0.74	46.46
1973-74	0.05	0.18	0.07	3.65	9.88	9.10	5.08	1.84	8.18	5.15	0.02	0.07	43.27
1974-75	2.57	0.10	0.00	2.82	2.38	4.95	4.25	10.16	9.90	5.41	0.84	0.63	44.01
1975-76	0.03	2.02	0.15	6.75	2.04	0.74	0.49	3.03	2.66	2.42	0.91	0.05	21.29
1976-77	0.10	2.43	1.00	0.93	1.54	0.24	2.50	2.68	2.06	0.25	4.65	0.38	18.76 RECORD LOW
1977-78	0.00	0.00	0.58	0.24	4.76	9.72	10.85	8.31	8.67	7.97	0.19	0.23	51.52
1978-79	0.08	0.00	3.98	0.07	3.17	4.43	8.45	7.60	6.05	1.86	2.88	0.02	38.59
1979-80	0.17	0.03	0.00	4.66	4.63	5.22	14.62	13.03	3.61	3.09	4.33	0.77	54.16
1980-81	0.43	0.02	0.03	0.71	0.58	3.04	8.05	2.69	6.26	1.67	1.42	0.00	24.90
1981-82	0.06	0.00	0.15	5.27	8.76	8.39	6.08	8.08	11.23	8.19	0.12	1.34	57.67
1982-83	0.03	0.02	4.02	8.78	11.30	7.32	10.83	14.34	12.86	6.29	0.74	0.12	76.65 RECORD HIGH
1983-84	0.01	0.09	3.86	1.35	16.44	12.75	0.27	5.51	3.56	2.70	0.84	1.31	48.69
1984-85	0.00	0.05	0.73	3.97	10.28	2.58	1.52	3.13	5.84	0.86	0.07	0.28	29.31
1985-86	0.30	0.12	2.64	3.09	7.71	4.52	4.70	21.98	8.43	2.37	1.58	0.00	57.44
1986-87	0.02	0.00	2.18	0.00	0.49	0.73	3.42	5.89	5.21	0.79	1.63	0.15	20.51
1987-88	0.00	0.00	0.00	2.19	2.22	5.79	5.42	0.88	0.73	3.15	1.66	0.79	22.83
1988-89	0.00	0.00	0.05	0.07	6.96	4.29	1.45	2.73	10.08	1.41	0.74	0.02	27.80
1989-90	0.00	0.33	3.28	4.30	3.02	0.00	4.75	3.40	2.75	1.66	3.46	0.21	27.16
1990-91	0.00	0.11	0.59	0.41	1.62	1.30	0.40	1.79	16.08	1.74	2.54	1.54	28.12
1991-92	0.17	0.10	0.32	5.54	2.32	3.10	1.97	7.68	4.58	0.45	0.45	1.66	28.34
1992-93	3.26	0.35	0.00	3.05	0.44	9.61	12.19	8.74	6.29	2.07	1.24	2.43	49.67
1993-94	0.00	0.00	0.00	1.25	2.11	1.97	2.93	7.08	0.86	3.71	2.22	0.00	22.13
1994-95	0.00	0.00	0.77	2.82	7.92	3.68	18.32	1.14	18.76	6.98	6.72	1.02	68.13
1995-96	0.05	0.00	0.00	0.00	0.35	9.13	10.32	11.17	6.81	3.94	5.51	1.24	48.52
1996-97	0.05	0.01	0.23	2.55	7.14	16.19	18.16	0.80	0.53	0.82	0.51	1.24	48.23
1997-98	0.17	0.00	0.33	1.39	4.99	3.70	12.86	16.30	6.69	4.94	6.46	1.35	59.18
1998-99	0.00	0.00	2.84	0.49	5.12	3.13	8.93	9.71	2.63	3.03	1.28	1.03	38.19
1999-00	0.00	0.13	0.18	1.05	3.51	0.51	11.68	14.13	2.58	3.70	2.72	1.06	41.25
2000-01	0.00	0.07	0.96	3.17	1.01	1.59	4.69	4.70	3.08	5.39	0.00	0.07	24.73
2001-02	0.02	0.00	0.60	1.17	6.97	9.75	2.56	2.13	6.88	2.29	2.02	0.00	34.39
2002-03	0.00	0.00	0.09	0.00	7.42	11.17	1.12	3.50	3.81	9.36	2.69	0.00	39.16
2003-04	0.09	1.32	0.06	0.00	2.88	9.97	2.79	8.52	1.07	0.17	0.55	0.02	27.44
2004-05	0.02	0.00	0.19	7.66	2.93	6.67	10.52	6.95	9.35	3.35	5.76	0.80	54.20
2005-06	0.00	0.11	0.71	1.70	3.34	17.72	7.75	5.26	10.14	10.55	1.97	0.10	59.35
2006-07	0.08	0.00	0.01	1.53	3.56	5.25	2.08	8.70	1.30	2.61	1.33	0.10	26.55
2007-08	0.01	0.17	0.34	1.02	0.95	5.01	10.15	6.69	0.87	0.26	2.85	0.00	28.32
2008-09	0.00	0.00	0.00	1.65	6.17	5.08	5.88	6.98	6.78	1.97	3.37	0.79	38.67
2009-10	0.00	0.10	0.00	4.37	1.31	5.89	7.97	5.86	4.92	6.66	3.65	0.06	40.79
2010-11	0.00	0.00	0.00	8.67	7.15	14.21	2.15	5.76	15.22	1.94	2.94	3.21	61.25
2011-12	0.00	0.00	1.56	3.13	1.77	0.00	6.25	1.62	5.96	4.76	0.37	0.92	26.34
2012-13	0.00	0.00	0.00	1.27	5.78	12.56	0.64	0.93	3.26	1.11	1.48	0.80	27.83
2013-14	0.00	0.00	0.72	0.56	1.80	1.22	1.59	9.23	6.17	3.43	0.98	0.05	25.75
2014-15	0.52	0.03	1.03	0.15	3.72	7.25	0.13	4.49	0.43	3.08	2.75	0.80	24.38
2015-16	0.39	0.00	0.11	2.26	5.36	9.74	9.53	1.74	9.19	3.13	1.82	0.34	43.61
2016-17	0.00	0.00	0.00	7.26	3.19	8.30	22.25	20.47	5.49	8.06	0.59	0.46	76.07
2017-18	0.00	0.09	1.44	0.50	7.34	0.42	5.20	0.76	14.50	3.70	1.02	0.00	34.97
2018-19	0.00	0.00	0.00	1.92	8.21	3.07	9.84	15.37	8.97	2.07	7.43	0.46	57.34
2019-20	0.00	0.00	0.63	0.00	1.39	10.58	2.09	0.08	7.50	3.87	3.09	0.33	29.56
2020-21	0.00	0.23	0.10	0.00	2.38	3.40	7.28	2.44	2.83	1.31	0.18	0.00	20.15
2021-22	0.09	0.00	0.18	7.51	0.95	13.37	0.04	0.36	0.96	4.14	0.39	0.31	28.30
2022-23	0.00	0.29	2.27	0.02	0.00	0.00	0.00	0.00	0.00	0.00	0.00	0.00	2.58 Current Year
Average	0.15	0.21	0.74	2.23	4.64	5.98	6.39	6.07	5.64	3.38	1.87	0.62	37.90
2021-22 +/-	(0.15)	0.08	1.53	(2.21)	(4.64)	(5.98)	(6.39)	(6.07)	(5.64)	(3.38)	(1.87)	(0.62)	(35.32)

ANNUAL AVERAGE **37.90**

INCHES +/- ANNUAL AVERAGE **(35.32)**

PERCENT OF ANNUAL AVERAGE **7%**

Updated as of 2-Nov-22

Historical Rain VS Average

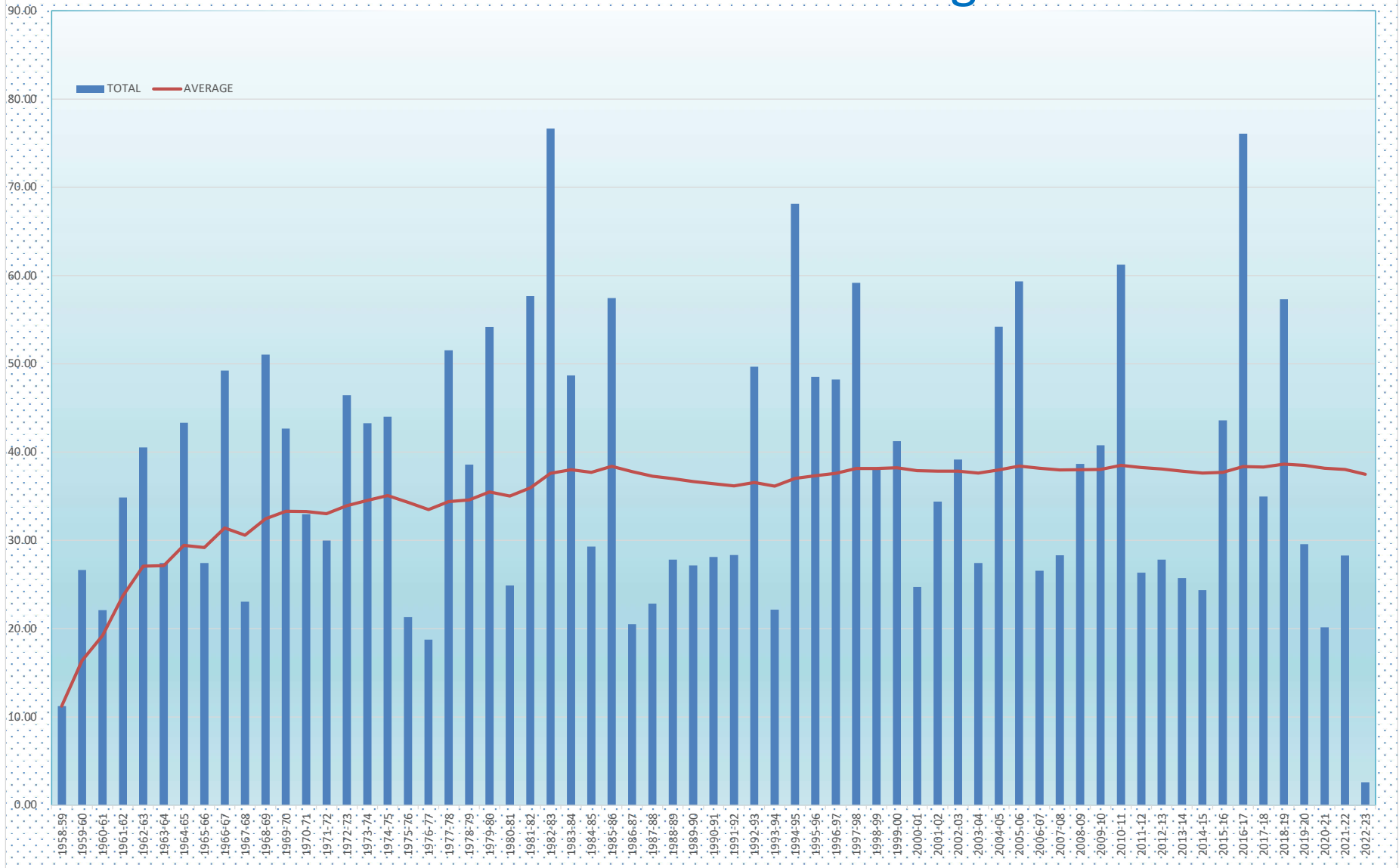

REGULATORY AFFAIRS BOARD REPORT

Susan Larson

November 17, 2022

FERC Compliance

- Hells Half Acre and Tulloch Spillway Road. Following the Board's approval of the P&P Engineering PSA, the initial kick off meeting was conducted on October 26, 2022 for both projects. The entire P&P engineering and design team walked both projects, and is now gathering the data to assist with both projects.
- Beardsley MOA for the Data Recovery Project. Work on this project is now complete, and all data and artifacts recovered over the past several years have been delivered to the USFS. Monitoring is also nearing completion.
- Coordination of license requirements for all licenses for inspection provisions within the D2SI (San Francisco Regional Office), and DHAC (Washington DC), to ensure proper coordination of pending requirements for gate inspections, shoreline erosion and other dam safety follow up, including Part 12 D follow up.
- FERC conference calls on dam safety matters, and multiple filings relative to Part 12 D matters, along with spillway and seismic safety issues of question by FERC. All current tasks are progressing well, timely, and will hopefully resort in resolution of questions that have been ongoing for the past several years. HDR has performed several studies on Tri-Dam's behalf, which are proving to be quite useful in bringing forth resolution of these outstanding items.

Permit and Other Assignments

- Work on permits, site reviews and compliance questions for various properties at Tulloch.
- Respond to daily inquiries from the public, and coordination with Calaveras and Tuolumne Marine Safety Units. Permits, inspections and file documentation.
- Tulloch compliance matters, as required.
- Working on pending litigation matters, as required.
- Working to wrap up the last set of open escrows at Tulloch, for project initiated many years ago.



Tri-Dam Project Generation & Revenue Report 2022

	Donnells				Beardsley				Tulloch				Project Total			
	Average Generation (1958-2018)	2022 Net Generation (kWh)	Avoided Generation (kWh)	2022 Energy Revenue	Average Generation (1958-2018)	2022 Net Generation (kWh)	2022 Energy Revenue	Average Generation (1958-2018)	2022 Net Generation (kWh)	2022 Energy Revenue	Average Generation (1958-2018)	2022 Net Generation (kWh)	2022 Energy Revenue	Average Generation (1958-2018)	2022 Net Generation (kWh)	2022 Energy Revenue
JAN	17,389,989	22,065,962	-	\$1,765,277	3,150,048	6,346,979	\$507,758	4,271,885	1,105,497	\$88,440	24,811,922	29,518,438	\$2,361,475	24,811,922	29,518,438	\$2,361,475
FEB	17,229,608	20,356,500	-	\$1,628,520	2,927,753	4,160,159	\$332,813	5,024,913	4,542,830	\$363,426	25,182,274	29,059,489	\$2,324,759	25,182,274	29,059,489	\$2,324,759
MAR	23,070,659	21,199,698	-	\$1,695,976	3,584,274	712,429	\$56,994	7,580,691	10,794,631	\$863,570	34,235,623	32,706,757	\$2,616,541	34,235,623	32,706,757	\$2,616,541
APR	31,686,865	25,641,336	-	\$2,051,307	4,717,464	6,239,458	\$499,157	10,811,027	9,993,391	\$799,471	47,215,356	41,874,184	\$3,349,935	47,215,356	41,874,184	\$3,349,935
MAY	41,216,149	23,096,110	-	\$1,847,689	5,799,593	3,884,238	\$310,739	12,131,040	14,298,993	\$1,143,919	59,146,782	41,279,340	\$3,302,347	59,146,782	41,279,340	\$3,302,347
JUN	42,555,036	30,939,288	-	\$2,475,143	6,336,073	6,160,441	\$492,835	12,084,818	15,417,779	\$1,233,422	60,975,928	52,517,508	\$4,201,401	60,975,928	52,517,508	\$4,201,401
JUL	36,444,466	12,729,928	-	\$1,018,394	6,629,514	4,981,005	\$398,480	12,609,174	12,915,743	\$1,033,259	55,683,154	30,626,677	\$2,450,134	55,683,154	30,626,677	\$2,450,134
AUG	27,568,740	17,237,748	-	\$1,379,020	6,269,748	1,317,251	\$105,380	11,868,293	11,530,563	\$922,445	45,706,781	30,085,561	\$2,406,845	45,706,781	30,085,561	\$2,406,845
SEP	20,111,167	6,477,711	-	\$518,217	5,223,523	4,704,246	\$376,340	8,577,620	8,026,323	\$642,106	33,912,310	19,208,280	\$1,536,662	33,912,310	19,208,280	\$1,536,662
OCT	12,743,535	2,323,885	-	\$185,911	3,752,220	496,473	\$39,718	4,664,124	6,814,313	\$545,145	21,159,879	9,634,670	\$770,774	21,159,879	9,634,670	\$770,774
NOV	12,042,987	-	-	\$0	2,794,775	-	\$0	2,487,256	-	\$0	17,325,019	-	\$0	17,325,019	-	\$0
DEC	14,354,891	-	-	\$0	3,713,920	-	\$0	3,288,702	-	\$0	21,357,513	-	\$0	21,357,513	-	\$0
Total	296,414,092	182,068,166	-	\$14,565,453	54,898,907	39,002,677	\$3,120,214	95,399,542	95,440,063	\$7,635,205	446,712,540	316,510,906	\$25,320,872	446,712,540	316,510,906	\$25,320,872

Note: Price per MWh is \$80.00

Tri-Dam Power Authority - Sand Bar

	Average Generation (1958-2018)	2022 Net Generation (kWh)	2022 Energy Revenue	PG&E Coordination Payment	Total Revenue
JAN	4,663,654	11,591,430	\$927,314	\$0	\$927,314
FEB	3,946,606	7,422,672	\$593,814	\$0	\$593,814
MAR	5,290,014	-	\$0	\$0	\$0
APR	6,873,822	7,146,240	\$571,699	\$0	\$571,699
MAY	8,065,189	7,151,326	\$572,106	\$0	\$572,106
JUN	8,750,023	8,488,900	\$679,112	\$0	\$679,112
JUL	9,133,101	6,996,309	\$559,705	\$0	\$559,705
AUG	8,560,581	1,083,010	\$86,641	\$0	\$86,641
SEP	6,928,285	6,777,927	\$542,234	\$0	\$542,234
OCT	4,898,944	755,759	\$60,461	\$0	\$60,461
NOV	2,947,604	-	\$0	\$0	\$0
DEC	5,554,123	-	\$0	\$0	\$0
Total	75,611,948	57,413,571	\$4,593,086	\$0	\$4,593,086

Tri-Dam Project Generation Revenue

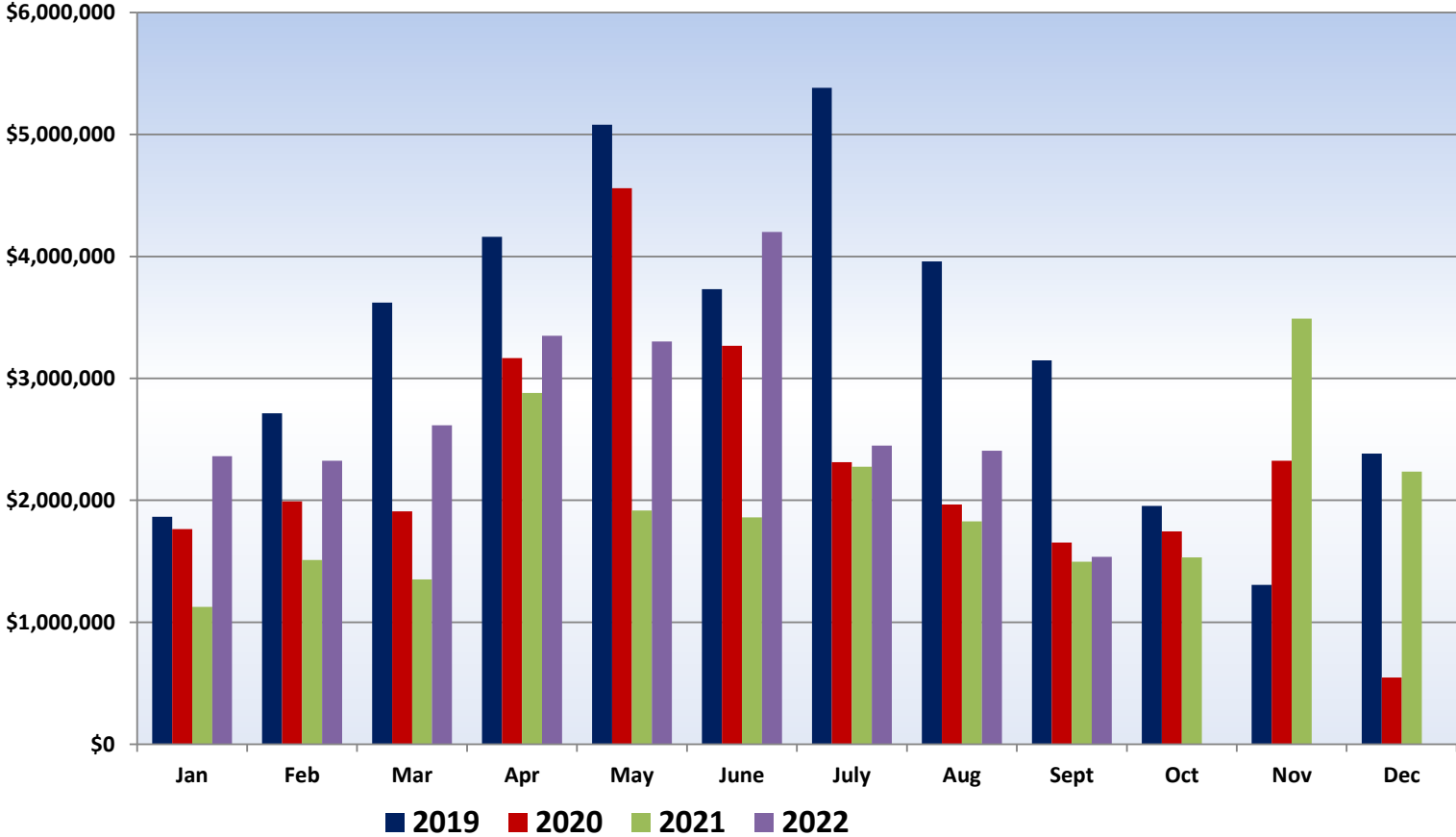

Tri-Dam Project Total Generation - MWh

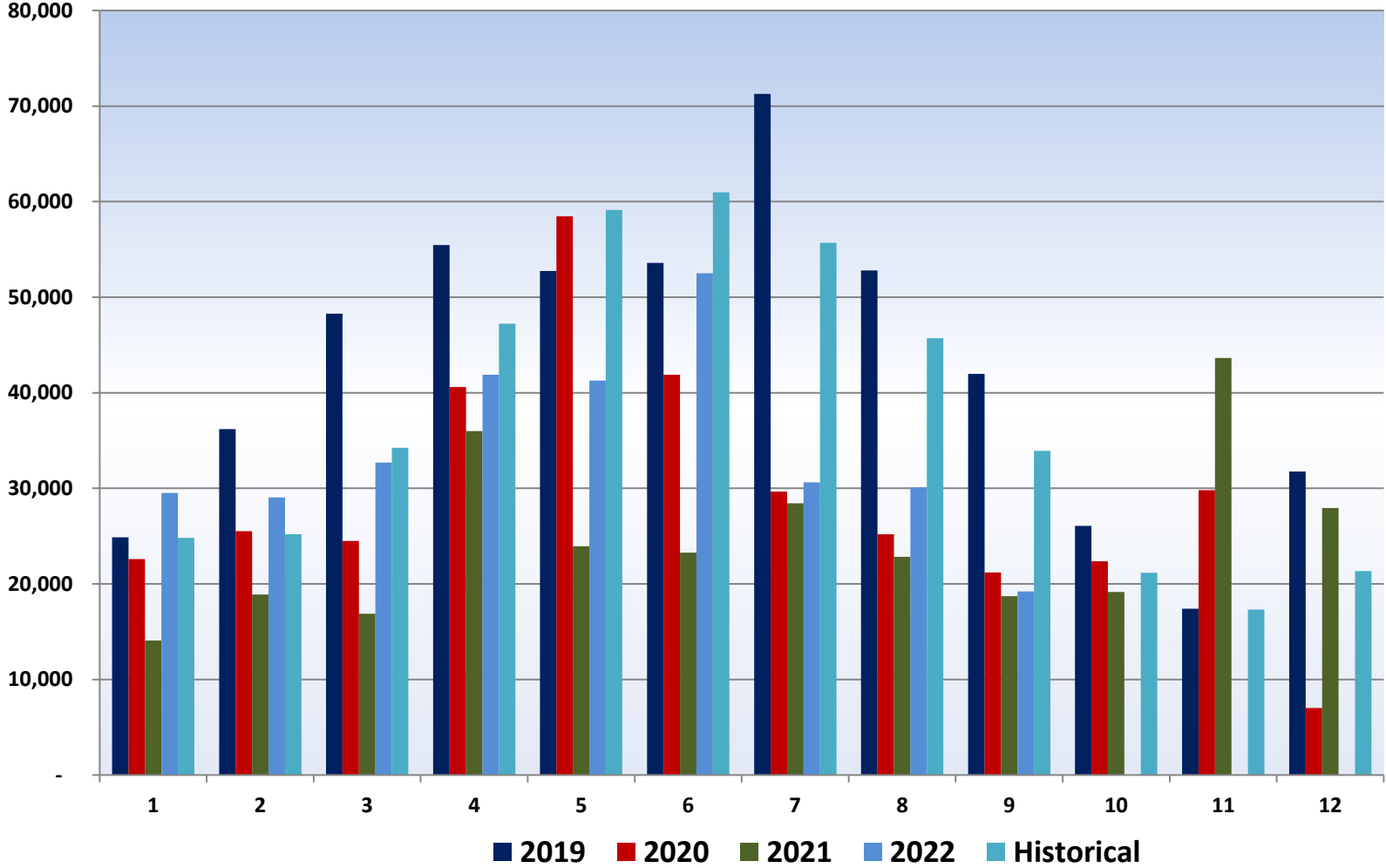

Tri-Dam Project Storage AF - Donnells & Beardsley

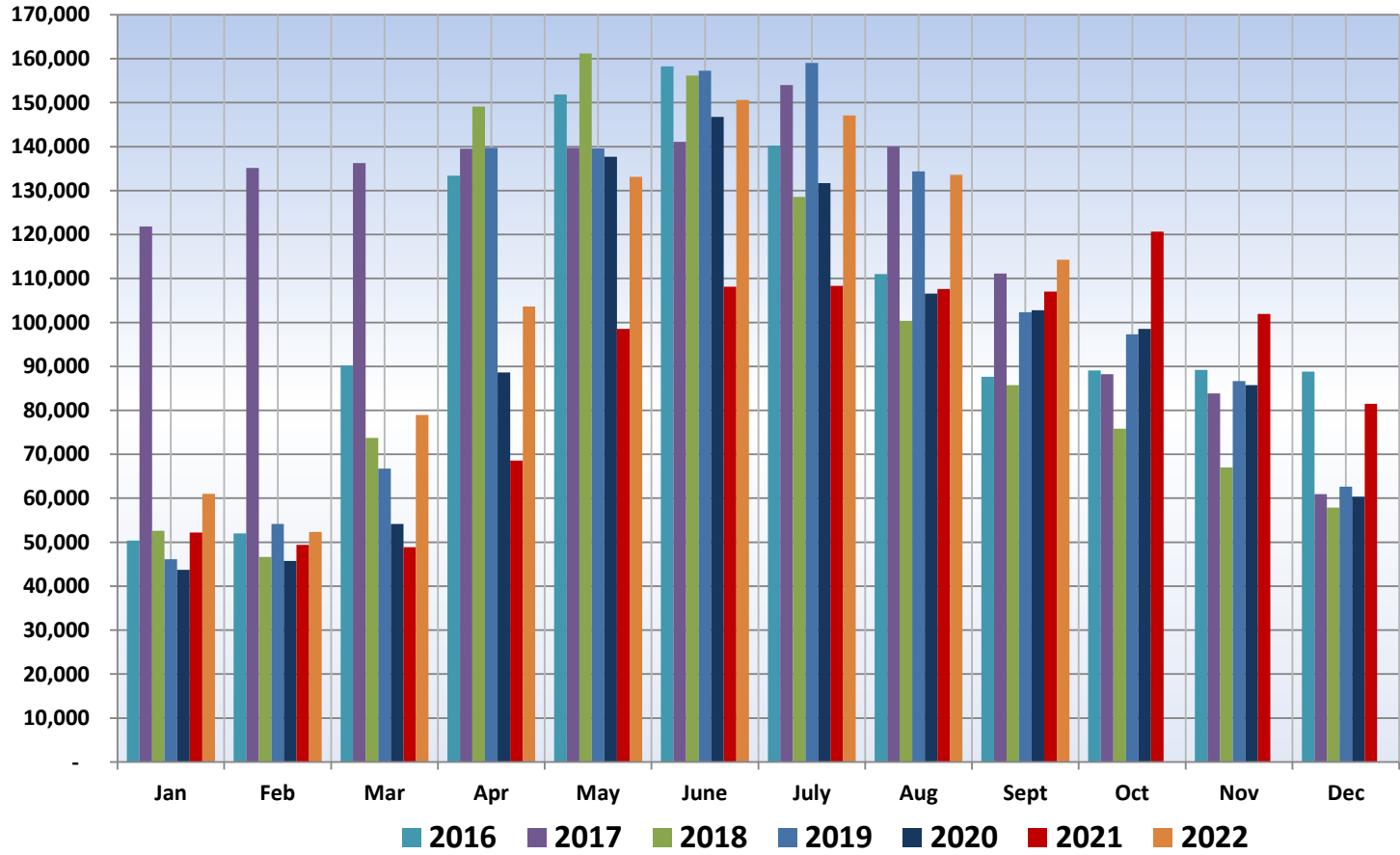

WESTERN PRICE SURVEY

[7] Energy Prices Up With Cooler Weather

Western natural gas prices increased as digits on thermometers across the region decreased.

Regional natural gas usage increased, elevating most natural gas values by more than a dollar in Oct. 27 to Nov. 3 trading.

California natural gas usage increased by 0.2 Bcf per day, or 4 percent, week over week, according to the U.S. Energy Information Administration, while Pacific Northwest demand rose by 1 Bcfd, or 6 percent.

The EIA specifically noted lower-than-average temperatures in the Sacramento area and mercury falling “significantly” across Seattle throughout the past two weeks.

Western natural gas values added between 57 cents and as much as \$3.80, led by Alberta gas, which jumped from \$1.15/MMBtu to \$4.95/MMBtu in trading. Seven hubs increased by a dollar or more in trading. Although it posted the most modest increase at 57 cents, PG&E CityGate had the highest regional price at \$8/MMBtu. Henry Hub natural gas, however, dropped 64 cents to \$4.66/MMBtu by Nov. 3.

Meanwhile, Western daytime power prices generally rose by between \$5.60 and as much as \$16.90 in trading. South of Path 15 gained the most value, up \$16.90 to \$69.25/MWh. Mid-Columbia peak power proved the exception, dropping \$21.30 to \$34.95/MWh.

Off-peak power values were uniformly higher, led by Mid-C nighttime power, which rose \$12.70 to \$72.10/MWh.

California Independent System Operator grid demand fell roughly 2,390 MW week over week, down to 27,207 MW on Nov. 3 compared with Oct. 21 demand of 29,594 MW. Western Power Pool demand peaked at 67,672 MW Nov. 3.

Southern California Gas Co. said maintenance on Line 225 that was to have wrapped up by Nov. 5 is now scheduled to end Nov. 12. Receipt capacity in the Wheeler Ridge Zone has decreased from 765 MMcf per day to 710 MMcf, while capacity in several other zones and areas will increase by between 70 MMcf and as much as 210 MMcf.

The utility on its ENVOY system reported a string of high operational flow orders between Oct. 27 and Nov. 3, save for Oct. 30. These were interspersed with low-OFO notices.

In October, the average high peak price at Henry Hub was \$6.91/MMBtu, 68 cents more than in 2021 (see “Price Trends,” next page).

PG&E CityGate was the only Western hub to post a year-over-year gain. It increased \$1.65 to \$8.19/MMBtu. Malin and SoCal Border gas hub prices moved lower by 53 cents and a penny, respectively, year over year. They ended at \$6.56/MMBtu and \$7.45/MMBtu.

Average Western peak power prices for October were generally higher compared with the year prior. Palo Verde added the most year over year, up \$31.15 to \$92.65/MWh. The high value at Mid-C dropped by \$7.25 year over year to \$74.80/MWh. **—Linda Dailey Paulson**

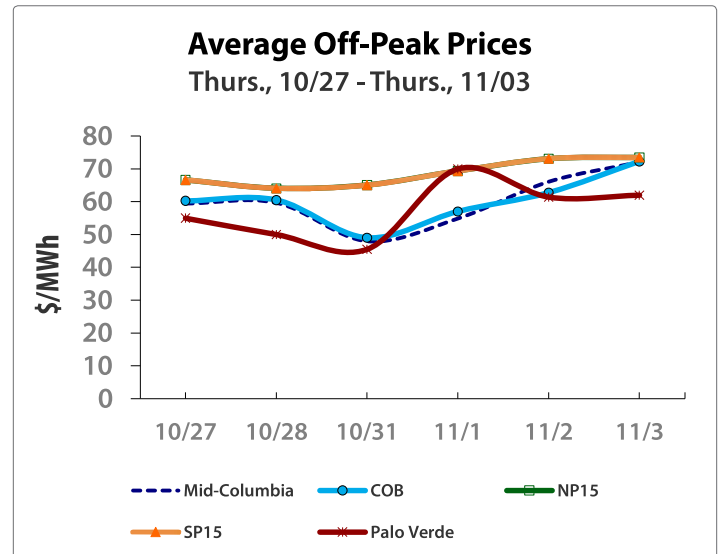
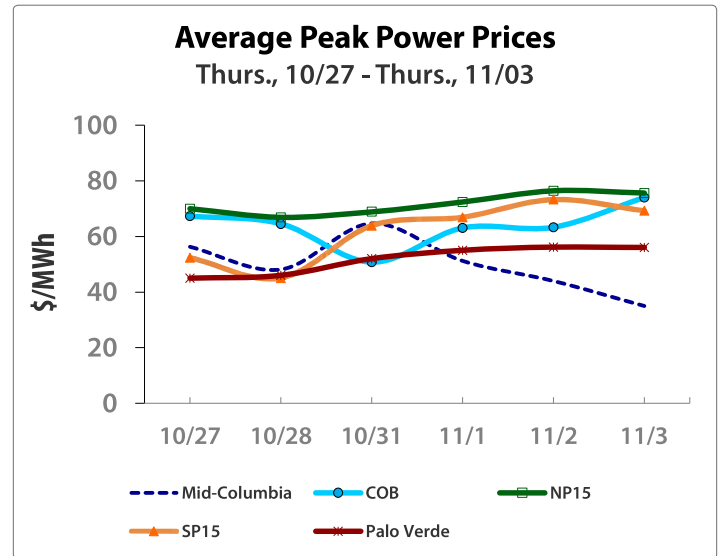

Average Natural Gas Prices (\$/MMBtu)

	Thurs. 10/27	Tues. 11/01	Thurs. 11/03
Henry Hub	5.30	4.47	4.66
Sumas	6.27	7.19	7.57
Alberta	1.15	5.18	4.95
Malin	6.40	7.31	6.98
Opal/Kern	5.54	6.41	6.52
Stanfield	6.30	7.23	7.40
PG&E CityGate	7.43	7.84	8.00
SoCal Border	5.38	6.47	6.78
SoCal CityGate	5.84	7.71	7.25
EP-Permian	0.89	2.48	1.86
EP-San Juan	4.66	5.89	6.39

Power/gas prices courtesy Enerfax



CURRENT RESERVOIR CONDITIONS

CALIFORNIA MAJOR WATER SUPPLY RESERVOIRS

Midnight - November 8, 2022

CURRENT CONDITIONS

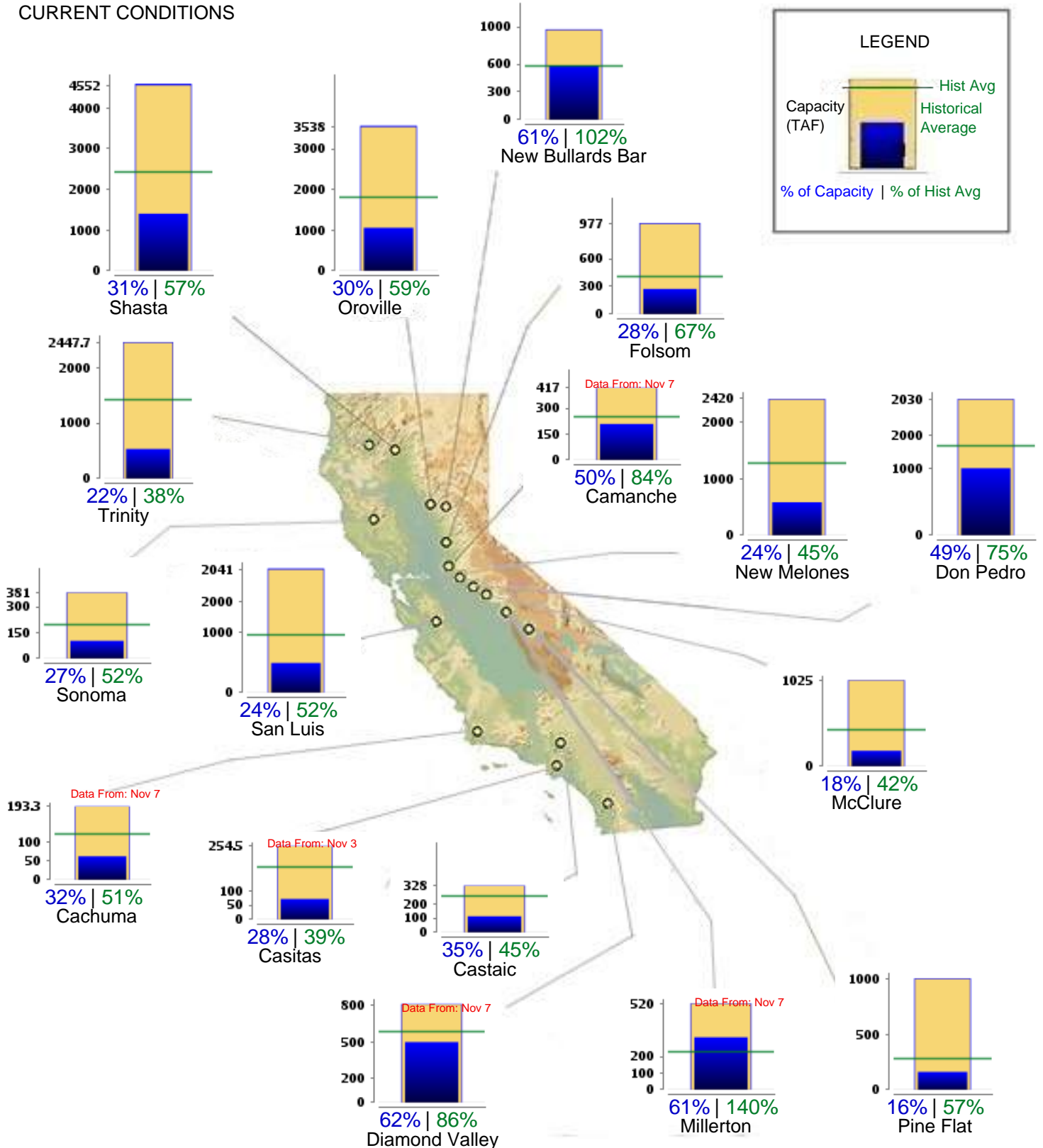



November 7, 2022

Tri Dam Project
Jeff Shields
P.O. Box 1158
Pinecrest, CA 95364

Re: October 2022 Invoices

Dear Mr. Shields:

Enclosed are invoices for consulting services provided by FISHBIO during October. Services provided for each project are summarized below.

Publications

Manuscripts characterizing predator diets and striped bass occupancy patterns were recently submitted to be considered for publication. Both are papers based primarily on the results on the non-native predator study which is the first multi-year assessment of predator abundance, distribution, and diets in the San Joaquin Basin. Comments on the predator diets manuscript were received in late October and revisions are underway to address the comments received before re-submitting the paper. Work also focused on modeling black bass abundance and survival for publication in development.

Non-Native Investigation/ Predator Study

During October efforts focused on reviewing video footage collected during sampling and entering data from the video review.

Consulting

On October 19 we met with Scot Moody and Peter Reitkerk regarding potential habitat restoration on the Stanislaus River and provided follow-up information regarding potential sites and quantities of habitat that could be created or restored.



Budget Summary

2022	<i>Life-cycle Monitoring</i>	<i>Publications</i>	<i>Consulting</i>	<i>Non-natives</i>	TOTAL
<i>Jan</i>	\$ 14,420.93	\$ -	\$ -	\$ 41,998.79	\$ 56,419.72
<i>Feb</i>	\$ 29,685.33	\$ 19,297.50	\$ -	\$ 80,925.68	\$ 129,908.51
<i>Mar</i>	\$ 21,981.66	\$ 4,302.50	\$ -	\$ 86,368.95	\$ 112,653.11
<i>Apr</i>	\$ 22,586.65	\$ 3,945.00	\$ 150.00	\$ 76,074.51	\$ 102,756.16
<i>May</i>	\$ 10,853.61	\$ 2,885.00	\$ -	\$ 61,864.22	\$ 75,602.83
<i>Jun</i>	\$ 4,303.43	\$ 9,870.00	\$ -	\$ 38,622.22	\$ 52,795.65
<i>Jul</i>	\$ 3,905.00	\$ 9,290.00	\$ 450.00	\$ 21,687.04	\$ 35,332.04
<i>Aug</i>	\$ 36,350.64	\$ 13,402.50	\$ -	\$ 34,471.54	\$ 84,224.68
<i>Sep</i>	\$ 11,272.30	\$ 10,402.50	\$ -	\$ 28,421.88	\$ 50,096.68
<i>Oct</i>	\$ -	\$ 20,667.50	\$ 5,145.00	\$ 7,819.96	\$ 33,632.46
TOTAL	\$ 155,359.55	\$ 94,062.50	\$ 5,745.00	\$ 478,254.79	\$ 733,421.84
<i>Estimated 2022</i>	\$ 150,000.00	\$ 125,000.00	\$ 25,000.00	\$ 475,000.00	\$ 775,000.00
<i>Remaining</i>	\$ (5,359.55)	\$ 30,937.50	\$ 19,255.00	\$ (3,254.79)	\$ 41,578.16

Sincerely,

Andrea Fuller

SJB October Field Report

Fall-run Adult Migration Monitoring

A total of 1,559 Chinook salmon were observed passing the Stanislaus River weir during October, increasing the season total to 1,561 (Figure 1). Fall attraction pulse flows occurred October 12-31 with flows and shaped into three peaks to simulate natural run-off events. Passage peaked at 336 Chinook on October 28 simultaneous with the final peak (Figure 2). Passage to date is less than half the number observed by end of October 2021 but slightly higher than in both 2019 and 2020. Total season passage at the weir over the last five years was highest in 2017 (8,500); however, this was approximately 40% less than the modern-day record number of 14,399 passages observed one year prior in 2016.

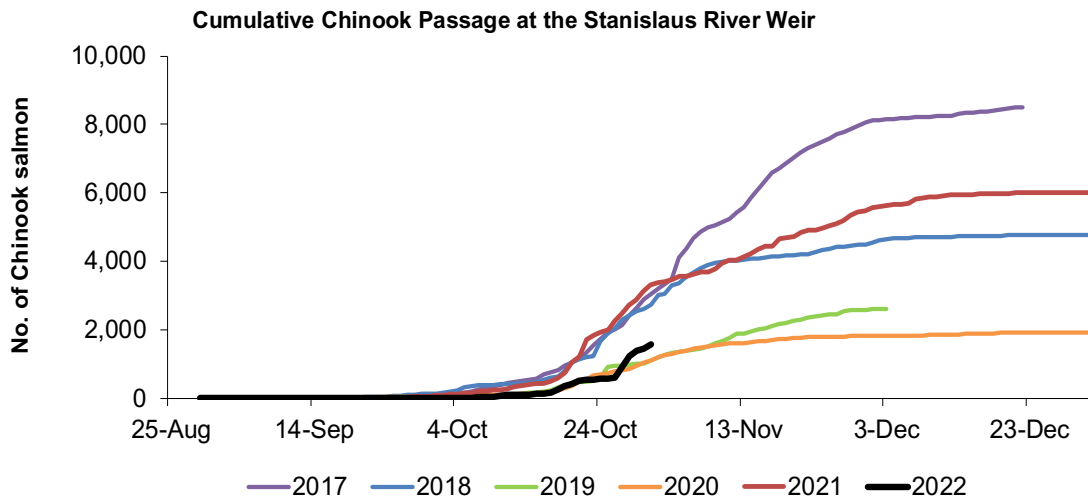

Figure 1. Cumulative Chinook salmon passage at the Stanislaus River weir, 2017-2022.

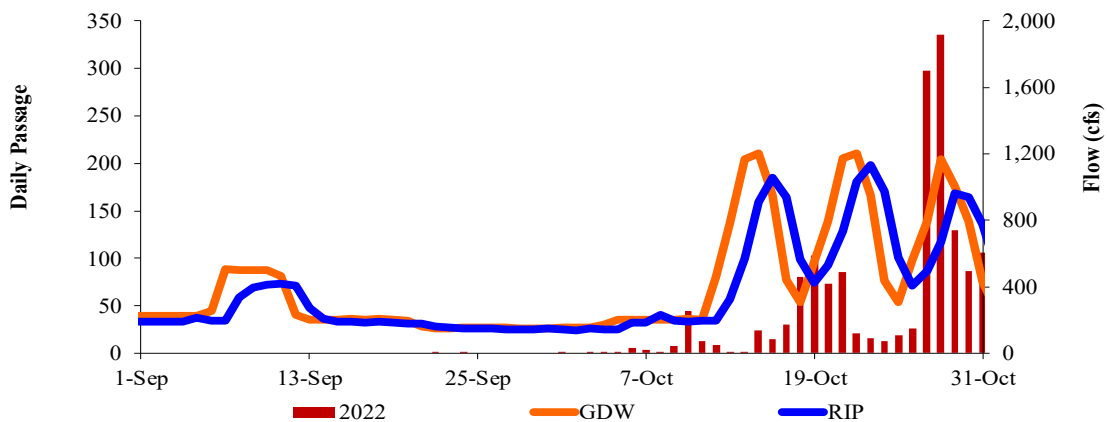

Figure 2. Daily Chinook salmon passage at the Stanislaus River weir and river flow at Goodwin (GDW) and Ripon (RIP).

As of October 31, a total of 233 Chinook salmon were observed in the Tuolumne River (Figure 3). Although passages to date at the Tuolumne weir were nearly double compared to the year before, Chinook salmon passages were 90% less than the numbers observed by the end of October in 2018 (n=2,029). The Tuolumne River fall attraction flow began on October 17 and consisted of two peaks of approximately 1,300 cfs (Figure 4). Passages during this time were likely underestimated since weir panels had to be temporarily submerged to allow massive amounts of water hyacinth to pass through the weir site with the increase in flow. Normal weir operations resumed once flows reached lower levels and the water hyacinth moved past the weir.

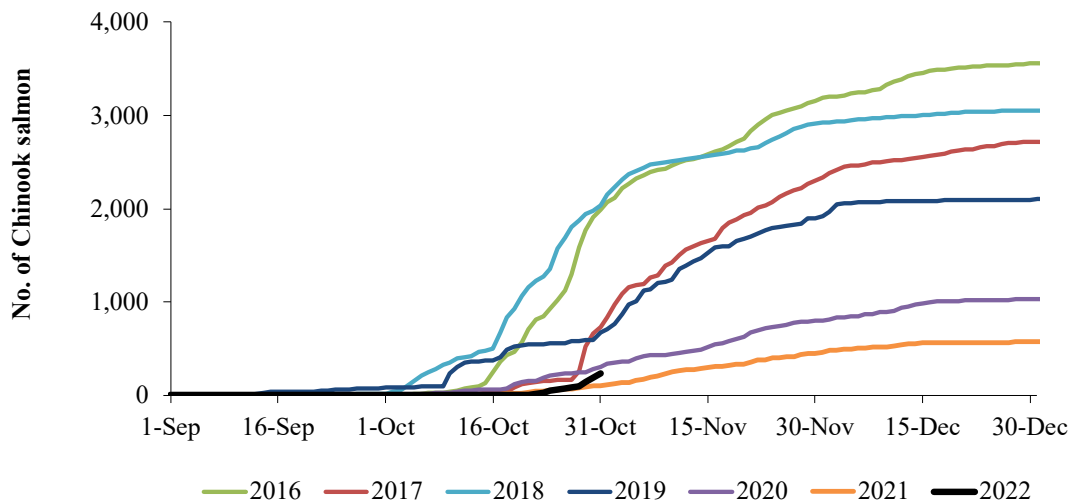

Figure 3. Cumulative Chinook salmon passage at the Tuolumne River weir, 2017-2022.

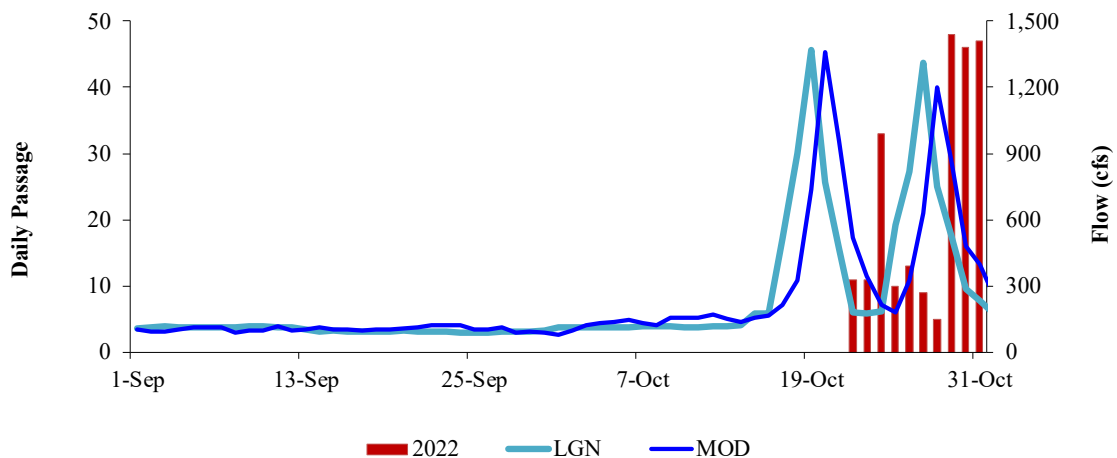

Figure 4. Daily Chinook salmon passage at the Tuolumne River weir and river flow at La Grange (LGN) and Modesto (MOD).

To date, 22% and 20% of all Chinook passing through the Stanislaus and Tuolumne weirs, respectively, have a clipped adipose fin indicating hatchery origin. As approximately 25% of hatchery production is adipose fin clipped, this suggests that most of the fish migrating into the Stanislaus and Tuolumne rivers are of hatchery origin. During September and early October 2022 observations of early spawning were reported in the Tuolumne River. Heads were recovered from spawned out carcasses to check for coded-wire tags (CWTs). Last year, early spawning was observed in both the Stanislaus and Tuolumne rivers. CWT results from 2021 confirmed the fish were all released as juveniles through the San Joaquin River Restoration Program (SJRRP) in the upper San Joaquin River (Steve Tsao of CDFW, personal communication). The Tuolumne weir operated normally prior to the pulse flow and no salmon were detected between September 30 and October 17, indicating the early spawners migrated upstream prior to the weir installation on September 30.

Escapement to the Mokelumne River through October 31 was approximately 1,000 fewer salmon than the number observed in 2021 during the same period but less than one-quarter of the numbers observed from 2017-2019 (Figure 5). A four-day pulse (peak: 1,125 cfs on October 18) followed by a smaller three-day pulse (peak: 650 cfs on November 1) occurred on the Mokelumne River during the month. The initial (largest) peak triggered 1,278 salmon to pass through the Woodbridge Fish Ladder over a four-day period.

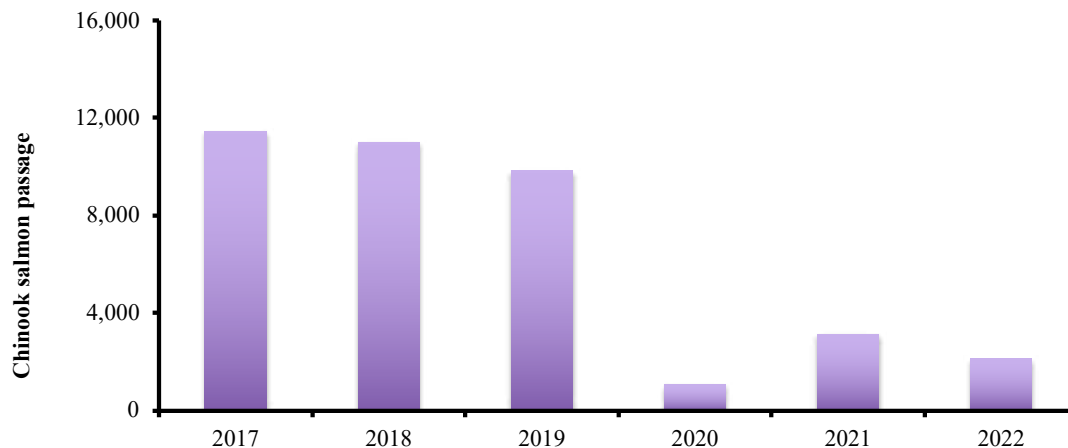

Figure 5. Chinook salmon passage through October 31 at the Mokelumne River fish ladder, 2017-2022.

Juvenile Outmigration Monitoring

Operation of the Calaveras River rotary screw trap (RST) began on October 31. The trap will sample weekdays and will be raised on the weekends from now through early to mid-summer. Last season, 1,272 *O. mykiss* (460 young-of-the-year [YOY], 808 Age 1+, and

four adult) were captured in the Calaveras RST, which was approximately 700 fewer *O. mykiss* captured than the previous year. Additionally, 380 juvenile Chinook salmon were captured in 2022 between late January and early June.

Summer Snorkel Surveys

Estimated abundance of *O. mykiss* (all life stages combined) in the Calaveras River in 2022, excluding the Dam reach, was 17,392 (95% confidence interval: 12,775 - 22,009), a slight increase over the 16,260 fish estimated in 2021 (Figure 6). Fish density was highest in the Jenny Lind reach (2,405 individuals per mile), followed by the Canyon (617 individuals per mile) and Shelton reaches (493 individuals per mile; Figure 3). Notably, fish density decreased by nearly 50% in the Canyon reach compared to the previous year, while abundance more than doubled in the Jenny Lind reach. In the Shelton reach, fish density remained stable.

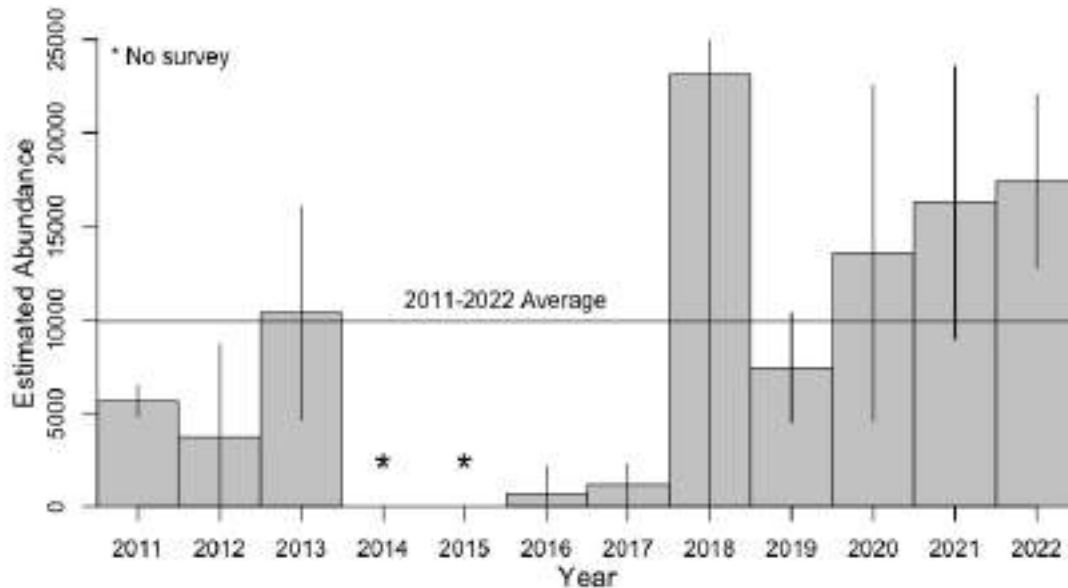

Figure 6. Annual *O. mykiss* abundance in the Calaveras River during 2011-2022.

Data is currently being analyzed for the Tuolumne and Stanislaus Rivers and abundance estimates should be available in the next month.

Native Fish Plan

The PIT tag antenna was installed at the Stanislaus River weir to collect additional data on movement of NFP tagged fish. A total of 16 individual fish (6 hardhead, 1 largemouth bass, 2 smallmouth bass, 6 spotted bass, 1 striped bass) were detected at the Stanislaus River weir between October 2-30. The striped bass was detected on three different days in October. Half of the fish were tagged in 2022 while the remaining eight were originally captured and tagged in 2020 or earlier. Only two of the individuals were initially captured

and tagged within half a mile of the weir while the remaining fish migrated approximately 1.5-27 miles from the initial location of capture (Table 1).

Table 1. Detection of PIT tagged predator species at the Stanislaus River weir.

Species	FishCode	Tagging Date	Tagging Location (RM)	Detection Date
Hardhead	NFP-2019-352	5/1/19	15.4	10/14/22
Hardhead	NFP-2019-1664	6/21/19	18.6	10/14/22
Hardhead	NFP-2019-1629	6/19/19	31.2	10/14/22
Hardhead	NFP-2019-261	4/1/19	31.8	10/14/22
Hardhead	NFP-2020-979	6/10/20	17.4	10/14/22
Hardhead	NFP-2020-483	5/15/20	36.1	10/22/22
Largemouth bass	NFP-2022-752	4/28/22	25.7	10/20/22, 10/23/22
Spotted bass	NFP-2022-164	2/10/22	4.8	10/20/22
Spotted bass	NFP-2020-895	6/11/20	5.8	10/13/22, 10/14/22
Spotted bass	NFP-2022-1119	5/4/22	13.6	10/14/22
Spotted bass	NFP-2022-591	4/1/22	20.1	10/9/22, 10/14/22
Spotted bass	NFP-2022-562	3/30/22	32.9	10/13/22
Spotted bass	NFP-2020-853	6/9/22	24.7	10/13/22
Striped bass	NFP-2022-1027	5/5/22	16.4	10/2/22, 10/3/22, 10/14/22
Smallmouth bass	NFP-2022-1211	5/17/22	24.7	10/14/22
Smallmouth bass	NFP-2022-859	4/26/22	32.9	10/30/22

TRI-DAM

POWER

AUTHORITY

**REGULAR BOARD MEETING
AGENDA
TRI-DAM POWER AUTHORITY
of THE OAKDALE IRRIGATION DISTRICT and
THE SOUTH SAN JOAQUIN IRRIGATION DISTRICT
NOVEMBER 17, 2022**

Start time is immediately following the Tri-Dam Project meeting
which begins at 9:00 AM

**Oakdale Irrigation District
1205 East F Street
Oakdale, CA 95361**

*** SEE BELOW FOR INSTRUCTIONS REGARDING PUBLIC
COMMENT AND PARTICIPATION**

NOTICE: Coronavirus (COVID-19)

A COMPLETE COPY OF THE AGENDA PACKET WILL BE AVAILABLE ON THE OAKDALE IRRIGATION DISTRICT WEB SITE (www.oakdaleirrigation.com) ON MONDAY, NOVEMBER 14, 2022 AT 9:00 A.M. ALL WRITINGS THAT ARE PUBLIC RECORDS AND RELATE TO AN AGENDA ITEM WHICH ARE DISTRIBUTED TO A MAJORITY OF THE BOARD OF DIRECTORS LESS THAN 72 HOURS PRIOR TO THE MEETING NOTICED ABOVE WILL BE MADE AVAILABLE ON THE OAKDALE IRRIGATION DISTRICT WEB SITE (www.oakdaleirrigation.com).

**INFORMATION FOR MEETING DURING CONTINUED PROCLAIMED STATE
OF EMERGENCY**

(Effective 3/27/2020 – until further notice):

Pursuant to California Governor Gavin Newsom's Executive Order N-29-20, a local legislative body is authorized to hold public meetings via teleconferencing and to make public meetings accessible telephonically or otherwise electronically to all members of the public who wish to participate and to provide public comment to the local legislative body during the current health emergency. The Tri-Dam Project and Tri-Dam Power Authority Board of Directors (Tri-Dam Directors) will adhere to and implement the provisions of the Governor's Executive Order related to the Brown Act and the utilization of technology to facilitate participation.

*The location of the Tri-Dam meeting will be at the office of the Oakdale Irrigation District, 1205 East F Street, Oakdale and will be open to the public based on a reservation system. Be advised these facilities only have 3 – 4 seats available for public access due to implemented protection measures for the COVID-19 virus.

****Public members who wish to participate, listen to, and provide comment on agenda items can do so by telephone by calling 1 (669) 900-9128, Access Code: 358-572-1867. All speakers commenting on Agenda Items are limited to five (5) minutes.**

Members of the public may also submit public comments in advance by e-mailing nfiez@oakdaleirrigation.com by 4:30 p.m., Wednesday, November 16, 2022.

In addition to the mandatory conditions set forth above, the Tri-Dam Directors will use sound discretion and make reasonable efforts to adhere as closely as reasonably possible to the provisions of the Brown Act, and other applicable local laws regulating the conduct of public meetings.

In compliance with the Americans with Disabilities Act, a person requiring an accommodation, auxiliary aid, or service to participate in this meeting should contact the Executive Assistant at (209) 840-5504, as far in advance as possible but no later than 24 hours before the scheduled event. Best efforts will be made to fulfill the request.

CALL TO ORDER

ROLL CALL: John Holbrook, Bob Holmes, Dave Kamper, Glenn Spyksma, Mike Weststeyn Brad DeBoer, Herman Doornenbal, Tom Orvis, Linda Santos, Ed Tobias

PUBLIC COMMENT

CONSENT CALENDAR

ITEMS 1 – 3

Matters listed under the consent calendar are considered routine and will be acted upon under one motion. There will be no discussion of these items unless a request is made to the Board President by a Director or member of the public. Those items will be considered at the end of the consent items.

1. Approve the regular board meeting minutes of October 20, 2022.
2. Approve the October statement of obligations.
3. Approve the Financial Statements for the nine months ending September 30, 2022.

DISCUSSION

ITEM 4

4. Discussion of the 2023 Draft Budget – *to be presented at the meeting*
-

ADJOURNMENT

ITEMS 5 - 6

5. Commissioner Comments.
6. Adjourn to the next regularly scheduled meeting.

BOARD AGENDA REPORT

Date: 11/17/2022
Staff: Genna Modrell

SUBJECT: Tri-Dam Power Authority October 2022 Minutes

RECOMMENDED ACTION: Review and possible approval of October 20, 2022 Minutes

BACKGROUND AND/OR HISTORY:

Draft minutes attached.

FISCAL IMPACT: None

ATTACHMENTS: Draft minutes attached.

Board Motion:

Motion by: _____ **Second by:** _____

VOTE:

OID: DeBoer (Yes/No) Doornenbal (Yes/No) Orvis (Yes/No) Santos (Yes/No) Tobias (Yes/No)

SSJID: Holbrook (Yes/No) Holmes (Yes/No) Kamper (Yes/No) Spyksma (Yes/No) Weststeyn (Yes/No)

**TRI-DAM POWER AUTHORITY
MINUTES OF THE JOINT BOARD
OF COMMISSIONERS REGULAR MEETING**

October 20, 2022
Manteca, California

The Commissioners of the Tri-Dam Power Authority met at the office of the South San Joaquin Irrigation District in Manteca, California, on the above date for the purpose of conducting business of the Tri-Dam Power Authority, pursuant to the resolution adopted by each of the respective Districts on October 14, 1984.

President Doornenbal called the meeting to order at 10:27 a.m.

OID COMMISSIONERS

SSJID COMMISSIONERS

COMMISSIONERS PRESENT:

BRAD DeBOER
ED TOBIAS
LINDA SANTOS
TOM ORVIS
HERMAN DOORNENBAL

JOHN HOLBROOK
BOB HOLMES
MIKE WESTSTEYN
GLENN SPYKSMA
DAVE KAMPER

Also, Present:

Jeff Shields, Interim General Manager; Scot A. Moody, General Manager, Oakdale Irrigation District; Peter Rietkerk, General Manager, South San Joaquin Irrigation District; Sharon Cisneros, Chief Financial Officer, Oakdale Irrigation District; Susan Larson, License Compliance Coordinator, Tri-Dam Project; Genna Modrell, Finance Asst., Tri-Dam Project; Chris Tuggle, Operations and Maintenance Manager, Tri-Dam Project; Mia Brown, Counsel; Tim O'Laughlin, Counsel, via zoom.

PUBLIC COMMENT

No public comment.

CONSENT CALENDAR

- ITEM #1 Approve the regular board meeting minutes of September 15, 2022.**
- ITEM #2 Approve the September statement of obligations.**
- ITEM #3 Approve the Financial Statements for the seven months ending July 31, 2022.**
- ITEM #4 Approve the Financial Statements for the eight months ending August 31, 2022.**

Commissioner Weststeyn moved to approve items one through four on the consent calendar. Commissioner Santos seconded the motion.

The motion passed by the following roll call vote:

AYES: Doornenbal, DeBoer, Orvis, Santos, Tobias, Holbrook, Holmes, Kamper, Spyksma, Weststeyn
NOES: None
ABSTAINING: None
ABSENT: None

Communications

ITEM #5 Commissioner Comments

None.

ADJOURNMENT

President Doornenbal adjourned the meeting at 10:28 a.m.

The next Board of Commissioners meeting is scheduled for November 17, 2022, at the offices of Oakdale Irrigation District beginning at 9:00 a.m.

ATTEST:

Jeff Shields, Interim Secretary
Tri-Dam Project

DRAFT

BOARD AGENDA REPORT

Date: 11/17/2022
Staff: Genna Modrell

SUBJECT: Tri-Dam Power Authority October Statement of Obligations

RECOMMENDED ACTION: Recommend Approval of the October Statement of Obligations

BACKGROUND AND/OR HISTORY:

Submitted for approval is the October Statement of Obligations for Tri-Dam Power Authority.

FISCAL IMPACT: See Attachments

ATTACHMENTS: Tri-Dam Power Authority Statement of Obligations

Board Motion:

Motion by: _____ **Second by:** _____

VOTE:

OID: DeBoer (Yes/No) Doornenbal (Yes/No) Orvis (Yes/No) Santos (Yes/No) Tobias (Yes/No)

SSJID: Holbrook (Yes/No) Holmes (Yes/No) Kamper (Yes/No) Spyksma (Yes/No) Weststeyn (Yes/No)

Tri-Dam Power Authority

Statement of Obligations

October 1, 2022 to October 31, 2022

**TRI-DAM POWER AUTHORITY
STATEMENT OF OBLIGATIONS**

Period Covered
October 1, 2022 to October 31, 2022

Total Obligations: **9** **checks in the amount of** **\$5,141.66**
(See attached Vendor Check Register Report)

CERTIFICATION

OAKDALE IRRIGATION DISTRICT

SOUTH SAN JOAQUIN IRRIGATION DISTRICT

Thomas D. Orvis

John Holbrook

Ed Tobias

Robert A. Holmes

Linda Santos

Dave Kamper

Herman Doornenbal

Glenn Spyksma

Brad DeBoer

Mike Weststeyn

To: Peter Rietkerk, SSJID General Manager:

THE UNDERSIGNED, EACH FOR HIMSELF, CERTIFIES THAT HE IS PRESIDENT OR SECRETARY OF THE TRI-DAM POWER AUTHORITY; THAT THE AMOUNTS DESIGNATED ABOVE HAVE BEEN ACTUALLY, AND NECESSARILY AND PROPERLY EXPENDED OR INCURRED AS AN OBLIGATION OF THE TRI-DAM POWER AUTHORITY FOR WORK PERFORMED OR MATERIALS FURNISHED FOR OPERATIONS AND MAINTENANCE OF THE SAND BAR PROJECT; THAT WARRANTS FOR PAYMENT OF SAID AMOUNTS HAVE BEEN DRAWN ON THE SAND BAR PROJECT O & M CHECKING ACCOUNT AT OAK VALLEY COMMUNITY BANK, SONORA, CALIFORNIA.

TRI-DAM POWER AUTHORITY
PRESIDENT,

TRI-DAM POWER AUTHORITY
SECRETARY,

Herman Doornenbal, President Date

Jeff Shields, Interim Secretary Date

Authority

October Checks by Amount



Check	Vendor No	Vendor	Date	Description	Amount
208290	10333	Grainger Inc. W. W.	10/18/2022		210.57
208291	10439	McMaster-Carr Supply Co.	10/18/2022		747.87
208292	10500	OID ~ Routine	10/18/2022	Admin / Finance services	1,210.43
208293	11343	Tim O'Laughlin, PLC	10/18/2022		315.00
208294	10749	UPS	10/18/2022		6.65
208295	10900	Chase Cardmember Service	10/03/2022		188.74
208296	11333	Fedak & Brown LLP	10/19/2022		744.00
208297	10516	Pacific Gas & Electric Co.	10/26/2022		309.40
208298	10588	Santa Fe Electric Inc.	10/26/2022	Rewind relay coils	1,409.00
Report Total:					\$ 5,141.66

BOARD AGENDA REPORT

Date: 11/17/2022
Staff: Sharon Cisneros

SUBJECT: Tri-Dam Power Authority Financial Statements for the Nine Months ending September 30, 2022

RECOMMENDED ACTION: Approve the Financial Statements for the Nine Months ending September 30, 2022

BACKGROUND AND/OR HISTORY:

As of the financial statement date of September 30, 2022, the Tri-Dam Power Authority (TDPA) cash increased by \$4.1M over the prior year primarily due to an increase in power sales of \$3.6M compared to the prior year. Reserve funds in investments total just under \$1.1M.

TDP has realized 104.4% of its annual budgeted operating revenues for 2022, and only utilized 58.2% of its budgeted operating expenses. With the maintenance scheduled in November and December, staff anticipates that expenses will increase in relation to the annual budget.

Further details are available in the attachments.

FISCAL IMPACT: none

ATTACHMENTS: Financial Statements 9/30/2022 (unaudited)

Board Motion:

Motion by: _____ **Second by:** _____

VOTE:

OID: DeBoer (Yes/No) Doornenbal (Yes/No) Orvis (Yes/No) Santos (Yes/No) Tobias (Yes/No)

SSJID: Holbrook (Yes/No) Holmes (Yes/No) Kamper (Yes/No) Spyksma (Yes/No) Weststeyn (Yes/No)

Tri-Dam Power Authority

Statement of Net Position

September 30, 2022 and 2021

(unaudited)

	<u>2022</u>	<u>2021</u>
Assets		
Cash	\$ 5,140,648	\$ 1,073,086
Investments	1,093,122	1,088,491
Accounts Receivable	545,953	1,717
Prepaid Expenses	120,862	124,101
Inventory	5,424	5,424
Capital Assets	45,275,609	45,375,609
Accumulated Depreciation	<u>(22,851,858)</u>	<u>(22,454,353)</u>
Total Assets	<u><u>29,329,760</u></u>	<u><u>25,214,075</u></u>
Liabilities		
Accounts Payable	-	(3,452)
Due to Tri-Dam Project	<u>225,104</u>	<u>155,322</u>
Total Liabilities	<u><u>225,104</u></u>	<u><u>151,870</u></u>
Net Position		
Net Position - Beginning of Year	26,363,000	27,642,989
Distributions	(800,000)	(2,505,000)
YTD Net Revenues	<u>3,541,656</u>	<u>(75,784)</u>
Total Net Position	<u><u>29,104,656</u></u>	<u><u>25,062,205</u></u>
Total Liabilities and Net Position	<u><u>\$ 29,329,760</u></u>	<u><u>\$ 25,214,075</u></u>



Tri-Dam Power Authority
Statement of Revenues and Expenses
 Period Ending September 30, 2022

	MTD Budget	MTD Actual	MTD Budget Variance	Budget Variance %	Prior Year MTD Actual	Prior Year MTD Var	Prior Year Variance %	2022 Budget
Operating Revenues								
1 Power Sales	\$ 361,969	\$ 542,234	\$ 180,265	49.8%	\$ -	\$ 542,234	#DIV/0!	\$ 4,343,626
2 Other Operating Revenue	-	-	-	-	-	-	-	-
3 Total Operating Revenues	<u>361,969</u>	<u>542,234</u>	<u>180,265</u>	<u>49.8%</u>	<u>-</u>	<u>542,234</u>	<u>#DIV/0!</u>	<u>4,343,626</u>
Operating Expenses								
5 Salaries and Wages	29,754	26,710	(3,044)	-10.2%	65,782	(39,072)	-59.4%	357,049
6 Benefits and Overhead	19,864	8,386	(11,478)	-57.8%	25,442	(17,056)	-67.0%	238,370
7 Operations	1,861	309	(1,552)	-83.4%	-	309	0.0%	22,330
8 Maintenance	9,958	463	(9,495)	-95.4%	4,658	(4,195)	-90.1%	119,500
9 General & Administrative	28,259	70,973	42,714	151.1%	16,876	54,097	320.6%	339,112
10 Depreciation & Amortization	41,017	40,880	(137)	-0.3%	40,812	68	0.2%	492,198
11 Total Operating Expenses	<u>130,713</u>	<u>147,721</u>	<u>17,008</u>	<u>13.0%</u>	<u>153,570</u>	<u>(5,849)</u>	<u>-3.8%</u>	<u>1,568,559</u>
12 Net Income From Operations	231,256	394,513	163,257	70.6%	(153,570)	548,083	-356.9%	2,775,067
Nonoperating Revenues (Expenses)								
14 Investment Earnings	833	10,040	9,207	1104.8%	4	10,036	250900.0%	10,000
15 Interest Expense	-	-	-	-	-	-	0.0%	-
18 Total Nonoperating Revenues (Expenses)	<u>833</u>	<u>10,040</u>	<u>9,207</u>	<u>1104.8%</u>	<u>4</u>	<u>10,036</u>	<u>250900.0%</u>	<u>10,000</u>
19 Net Revenues	<u>\$ 232,089</u>	<u>\$ 404,553</u>	<u>\$ 172,464</u>	<u>74.3%</u>	<u>\$ (153,566)</u>	<u>\$ 558,119</u>	<u>-363.4%</u>	<u>\$ 2,785,067</u>
Memo:								
20 Capital Expenditures	<u>\$ 38,000</u>	<u>\$ -</u>	<u>\$ (38,000)</u>					<u>\$ 456,000</u>



Tri-Dam Power Authority
Statement of Revenues and Expenses
 Period Ending September 30, 2022

	<u>YTD Budget</u>	<u>YTD Actual</u>	<u>YTD Budget Variance</u>	<u>Budget Variance %</u>	<u>Prior Year Actual</u>	<u>Prior Year Variance</u>	<u>Prior Year Variance %</u>	<u>2022 Budget</u>
1 Operating Revenues								
2 Power Sales	\$ 3,257,720	\$ 4,532,625	\$ 1,274,906	39.1%	\$ 892,477	\$ 3,640,148	407.9%	\$ 4,343,626
3 Other Revenue	-	-	-	-	-	-	-	-
4 Total Operating Revenues	<u>3,257,720</u>	<u>4,532,625</u>	<u>1,274,906</u>	<u>39.1%</u>	<u>892,477</u>	<u>3,640,148</u>	<u>408%</u>	<u>4,343,626</u>
5								
6 Operating Expenses								
7 Salaries and Wages	267,787	205,673	(62,114)	-23.2%	249,638	(43,965)	-17.6%	357,049
8 Benefits and Overhead	178,778	72,732	(106,046)	-59.3%	108,537	(35,805)	-33.0%	238,370
9 Operations	16,748	2,442	(14,306)	-85.4%	4,158	(1,716)	-41.3%	22,330
10 Maintenance	89,625	10,964	(78,661)	-87.8%	20,661	(9,697)	-46.9%	119,500
11 General & Administrative	254,334	250,284	(4,050)	-1.6%	216,670	33,614	15.5%	339,112
12 Depreciation & Amortization	369,149	371,494	2,346	0.6%	367,311	4,183	1.1%	492,198
13 Total Operating Expenses	<u>1,176,419</u>	<u>913,589</u>	<u>(262,830)</u>	<u>-22.3%</u>	<u>966,975</u>	<u>(53,386)</u>	<u>-5.5%</u>	<u>1,568,559</u>
14								
15 Net Income From Operations	2,081,300	3,619,036	1,537,736	73.9%	(74,498)	3,693,534	-4957.9%	2,775,067
16								
17 Nonoperating Revenues (Expenses)								
18 Investment Earnings	7,500	9,579	2,079	27.7%	4,728	4,851	102.6%	10,000
19 Interest Expense	-	-	-	-	-	-	0.0%	-
22 Total Nonoperating Revenues (Expenses)	<u>7,500</u>	<u>9,579</u>	<u>2,079</u>	<u>27.7%</u>	<u>4,728</u>	<u>4,851</u>	<u>102.6%</u>	<u>10,000</u>
23								
24 Net Revenues	<u>\$ 2,088,800</u>	<u>\$ 3,628,615</u>	<u>\$ 1,539,814</u>	<u>73.7%</u>	<u>\$ (69,770)</u>	<u>\$ 3,698,385</u>	<u>-5300.8%</u>	<u>\$ 2,785,067</u>
25								
26								
27 Memo:								
28 Capital Expenditures	<u>\$ 342,000</u>	<u>\$ 86,959</u>	<u>\$ (255,041)</u>					<u>\$ 456,000</u>

BOARD AGENDA REPORT

Date: 11/17/2022
Staff: Jeff Shields
Sharon Cisneros

SUBJECT: 2023 Draft Budget

RECOMMENDED ACTION: Discussion of the 2023 Draft Budget

BACKGROUND AND/OR HISTORY:

This item will be presented at the meeting.

FISCAL IMPACT: See Attachments

ATTACHMENTS: Draft Budget
