



# **AGENDA MATERIALS**

## **TRI-DAM PROJECT**



### **TRI-DAM POWER AUTHORITY**



### **BOARD MEETING**

**April 20, 2023**

---

**REGULAR BOARD MEETING  
AGENDA  
TRI-DAM PROJECT  
of THE OAKDALE IRRIGATION DISTRICT and  
THE SOUTH SAN JOAQUIN IRRIGATION DISTRICT  
APRIL 20, 2023  
9:00 A.M.**

**South San Joaquin Irrigation District  
11011 Highway 120  
Manteca, CA 95336**

---

A COMPLETE COPY OF THE AGENDA PACKET WILL BE AVAILABLE ON THE OAKDALE IRRIGATION DISTRICT WEB SITE ([www.oakdaleirrigation.com](http://www.oakdaleirrigation.com)) ON MONDAY, APRIL 20, 2023 AT 9:00 A.M. ALL WRITINGS THAT ARE PUBLIC RECORDS AND RELATE TO AN AGENDA ITEM WHICH ARE DISTRIBUTED TO A MAJORITY OF THE BOARD OF DIRECTORS LESS THAN 72 HOURS PRIOR TO THE MEETING NOTICED ABOVE WILL BE MADE AVAILABLE ON THE OAKDALE IRRIGATION DISTRICT WEB SITE ([www.oakdaleirrigation.com](http://www.oakdaleirrigation.com)).

Members of the public who wish to attend and participate in the meeting remotely, as opposed to in-person, can do so via internet at <https://ssjid.zoom.us/j/98120276218> or by telephone, by calling 1 (669) 900-6833, Meeting ID: 981-2027-6218, Password: 700546. All speakers commenting on Agenda Items are limited to five (5) minutes.

Members of the public may also submit public comments in advance by e-mailing [dbarney@ssjid.com](mailto:dbarney@ssjid.com) by 4:30 p.m., Wednesday, April 19, 2023.

In compliance with the Americans with Disabilities Act, a person requiring an accommodation, auxiliary aid, or service to participate in this meeting should contact the Executive Assistant at (209) 249-4623, as far in advance as possible but no later than 24 hours before the scheduled event. Best efforts will be made to fulfill the request.

---

**CALL TO ORDER**

**PLEDGE OF ALLEGIANCE**

**ROLL CALL:** John Holbrook, Dave Kamper, David Roos, Glenn Spyksma, Mike Weststeyn  
Brad DeBoer, Herman Doornenbal, Tom Orvis, Linda Santos, Ed Tobias

**PUBLIC COMMENT**

---

**CONSENT CALENDAR**

**ITEMS 1 - 2**

1. Approve the regular board meeting minutes of March 16, 2023.

2. Approve the March statement of obligations.
- 

## **ACTION CALENDAR**

## **ITEMS 3 - 14**

3. Discussion and possible action to adopt Resolution TDP 2023-03 Authorization for Maintenance of Deposit Accounts.
  4. Discussion and possible action to approve moving the May Board meeting date.
  5. Discussion and possible action to authorize the General Manager to sign a letter of support for AB1594.
  6. Discussion and possible action to approve the Department of Water Resources annual dam fees.
  7. Discussion and possible action to approve the purchase of an emergency generator for Donnell's Dam.
  8. Discussion and possible action to approve replacing the roof on the Beardsley raw water tank.
  9. Discussion and possible action to approve replacing the forklift in Strawberry.
  10. Discussion and possible action to approve the purchase of 2023 International Dump Truck.
  11. Discussion and possible action to approve Microwave Networks Support Services Program.
  12. Discussion and possible action to approve the purchase of a new milling machine.
  13. Discussion and possible action to authorize the General Manager to sign the Professional Services Agreement with Archer Energy Solution, LLC.
  14. Discussion and possible action to approve the purchase of an SF6 Gas Scale.
- 

## **COMMUNICATIONS**

## **ITEMS 15 - 18**

15. Staff reports as follows:
    - a. General Manager Report
    - b. Operations & Maintenance Report
    - c. Compliance Report
  16. Generation Report
  17. Fisheries studies on the Lower Stanislaus River
  18. Directors' Comments
- 

## **CLOSED SESSION**

## **ITEM 19**

19. a. CONFERENCE WITH LEGAL COUNSEL – EXISTING LITIGATION  
Government Code § 54956.9(d)(1)

1. *San Joaquin Tributaries Authority, et al v. California State Water Resources Control Board*  
County of Sacramento Superior Court  
Case No. JCCP 5013
2. *San Joaquin Tributaries Authority v. California State Water Resources Control Board*  
(2021 Curtailment Case)  
County of Fresno Superior Court  
Case No. 21CECG02632
3. *Lee Tyler et al. v. Oakdale Irrigation; et al.*  
Calaveras Superior Court Case No. 17CV42319
4. *Tri-Dam v. Scott Frazier*  
Eastern District of California No: 1:20-CV-00408-SKO

b. CONFERENCE WITH LEGAL COUNSEL – ANTICIPATED LITIGATION

Significant Exposure to Litigation  
Government Code § 54956.9(d)(2)  
One (1) case

c. REAL PROPERTY NEGOTIATIONS

Property: Water  
Negotiating Parties: Oakdale Irrigation District, Chicken Ranch Rancheria Band of MeWuk Indians, Stockton East Water District, South Delta Water Agency, Banta Carbona Irrigation District, and other potential unknown parties  
District Negotiator: General Manager  
Under Negotiation: Price and terms of payment of sale

d. REAL PROPERTY NEGOTIATIONS

Government Code § 54956.8  
Property: 043-110-026 and 043-110-032  
Agency Negotiator: General Manager  
Negotiating Parties: Billie Jean Tichenor Trust  
Under Negotiation: Price and Terms

e. REAL PROPERTY NEGOTIATIONS

Government Code § 54956.8  
Property: 061-057-001  
Agency Negotiator: General Manager  
Negotiating Parties: REA Properties, LLC  
Under Negotiation: Price and Terms

---

**ADJOURNMENT**

**ITEM 20**

20. Adjourn to the next regularly scheduled meeting

# BOARD AGENDA REPORT

Date: 4/20/2023  
Staff: Genna Modrell

---

**SUBJECT:** Tri-Dam Project March 2023 Minutes

---

**RECOMMENDED ACTION:** Review and possible approval of March 16, 2023 Minutes

---

**BACKGROUND AND/OR HISTORY:**

Draft minutes attached.

**FISCAL IMPACT:** None

**ATTACHMENTS:** March 16, 2023 Minutes

---

**Board Motion:**

**Motion by:** \_\_\_\_\_ **Second by:** \_\_\_\_\_

**VOTE:**

**OID:** DeBoer (Yes/No) Doornenbal (Yes/No) Orvis (Yes/No) Santos (Yes/No) Tobias (Yes/No)

**SSJID:** Holbrook (Yes/No) Kamper (Yes/No) Roos (Yes/No) Spyksma (Yes/No) Weststeyn (Yes/No)

**TRI-DAM PROJECT  
MINUTES OF THE JOINT BOARD  
OF DIRECTORS REGULAR MEETING**

March 16, 2023  
Oakdale, California

The Joint Boards of Directors of the Oakdale Irrigation District and the South San Joaquin Irrigation District met in joint session at the office of Oakdale Irrigation District in Oakdale, California, on the above date for the purpose of conducting business of the Tri-Dam Project, pursuant to the resolution adopted by each of the respective Districts on July 29, 1955.

President Orvis called the meeting to order at 8:00 a.m.

**OID DIRECTORS**

**SSJID DIRECTORS**

***DIRECTORS PRESENT:***

ED TOBIAS  
BRAD DeBOER  
TOM ORVIS  
HERMAN DOORNENBAL  
LINDA SANTOS

JOHN HOLBROOK  
MIKE WESTSTEYN  
GLENN SPYKSMA  
DAVID ROOS

**Also Present:**

Summer Nicotero, General Manager, Tri-Dam Project; Scot A. Moody, General Manager, Oakdale Irrigation District; Peter Rietkerk, General Manager, South San Joaquin Irrigation District; Sharon Cisneros, Chief Financial Officer, Oakdale Irrigation District; Susan Larson, License Compliance Coordinator, Tri-Dam Project; Genna Modrell, Finance Asst., Tri-Dam Project; Chris Tuggle, Operations and Maintenance Manager, Tri-Dam Project; Mia Brown, Counsel, SSJID; Scott Lewis, Provost & Pritchard

**PUBLIC COMMENT**

No public comment.

**CONSENT CALENDAR**

**ITEM #1    Approve the regular board meeting minutes of February 16, 2023.**

**ITEM #2    Approve the February statement of obligations.**

Director Santos moved to approve items one and two as presented. Director Holbrook seconded the motion.

The motion passed by the following roll call vote:

AYES: DeBoer, Doornenbal, Orvis, Santos, Tobias, Holbrook, Roos, Spyksma, Weststeyn

NOES: None

ABSTAINING: None

ABSENT: Kamper

## **ACTION CALENDAR**

### **ITEM #3 Review and possible action to approve the FERC annual land use fees.**

Summer Nicotero presented the invoices and explained the fees were for conducting business on government owned land.

Director Holbrook moved to approve as presented. Director Santos seconded the motion.

The motion passed by the following roll call vote:

AYES: DeBoer, Doornenbal, Orvis, Santos, Tobias, Holbrook, Roos, Spyksma, Weststeyn

NOES: None

ABSTAINING: None

ABSENT: Kamper

### **ITEM #4 Review and possible action to authorize the General Manager to proceed with the rock slide removal repair and authorize the General Manager to apply for FEMA and CalOES reimbursement under the recent emergency declaration, FEMA-4683-DR-CA.**

Summer Nicotero presented the resolution advising the bidding for this project will be handled by Provost and Pritchard and that FEMA provides 75% reimbursement including administrative fees while CalOES will reimburse 75% of the remaining FEMA balance.

Director Santos moved to authorize the General Manager to proceed as presented. Director Weststeyn seconded the motion.

The motion passed by the following roll call vote:

AYES: DeBoer, Doornenbal, Orvis, Santos, Tobias, Holbrook, Roos, Spyksma, Weststeyn

NOES: None

ABSTAINING: None

ABSENT: Kamper

### **ITEM #5 Review and possible action to adopt resolution for the designation of applicant's agent resolution non-state agencies.**

Summer Nicotero presented the resolution necessary to apply for FEMA aid and advised it would remain on file for three years.

Director Santos moved to adopt the resolution as presented. Director Weststeyn seconded the motion.

The motion passed by the following roll call vote:

AYES: DeBoer, Doornenbal, Orvis, Santos, Tobias, Holbrook, Roos, Spyksma, Weststeyn

NOES: None

ABSTAINING: None

ABSENT: Kamper

### **ITEM #6 Discussion and possible action to authorize the General Manager to hire a Natural Resources Intern at the Tulloch Reservoir, reporting to the License and Compliance Coordinator.**

Summer provided a brief history of this position and advised the Board of the added benefit of this person's presence on the reservoir.

Director Santos moved to approve as presented. Director Roos seconded the motion.

The motion passed by the following roll call vote:

AYES: Orvis, Santos, Tobias, Holbrook, Roos, Spyksma, Weststeyn  
NOES: DeBoer, Doornenbal  
ABSTAINING: None  
ABSENT: Kamper

**ITEM #7 Review and possible action to approve the crane rental to remove and replace the Beardsley spillway lower bridge.**

Chris Tuggle presented quotes from Bigge Crane and American Crane rentals to remove the bridge below Beardsley advising it will need to be done before we spill at 5000 cfs.

Director Holbrook moved to approve Bigge Crane for \$49,620 as presented. Director Santos seconded the motion.

The motion passed by the following roll call vote:

AYES: DeBoer, Doornenbal, Orvis, Santos, Tobias, Holbrook, Roos, Spyksma, Weststeyn  
NOES: None  
ABSTAINING: None  
ABSENT: Kamper

**COMMUNICATIONS**

**ITEM #9 Staff Reports:**

- A. General Manager, Summer Nicotero
  - Summer Nicotero provided a brief summary of her report.
- B. Operations and Maintenance Manager, Chris Tuggle
  - Chris Tuggle provided a brief summary of his report.
- C. License Compliance Coordinator, Susan Larson
  - Susan Larson provided a brief summary of her report

**ITEM #10 Generation Report**

No report.

**ITEM #11 Fisheries Studies on the Lower Stanislaus River**

No report.

**ITEM #12 Directors Comments**

The Directors expressed their appreciation to all staff for their efforts and hard work during the recent storm events and difficult conditions.

Directors Santos and Roos reported on their attendance at Farm Bureau, TuCARE dinners.

**ITEM #8 Tulloch Spillway Study Session Report**

Susan Larson and Scott Lewis, Provost & Pritchard, provided a status update on the Tulloch Spillway, the primary cause, proposals to repair and responded to Director questions.

*President Orvis recessed to the Tri-Dam Power Authority Board of Commissioners meeting at 9:43 a.m.*

*The Tri-Dam Project meeting resumed at 9:55 a.m. after the Tri-Dam Power Authority meeting adjourned.*



President Orvis announced before closed session that the following items would be discussed. The Board took a brief recess at 9:56 a.m. and convened to Closed Session at 10:12 a.m.

**ITEM #13 Closed Session**

- 13. a. PUBLIC EMPLOYMENT  
Government Code sec. 54957(b)  
1. Finance Manager
  
- b. CONFERENCE WITH LEGAL COUNSEL – ANTICIPATED LITIGATION  
Possible Initiation of Litigation  
Government Code § 54956.9(d)(4)  
One (1) case
  
- c. REAL PROPERTY NEGOTIATIONS  
Government Code § 54956.8  
Property: 043-110-026 and 043-110-032  
Agency Negotiator: General Manager  
Negotiating Parties: Unknown  
Under Negotiation: Price and Terms
  
- d. REAL PROPERTY NEGOTIATIONS  
Government Code § 54956.8  
Property: 061-057-001  
Agency Negotiator: General Manager  
Negotiating Parties: REA Properties, LLC  
Under Negotiation: Price and Terms

At the hour of 11:00 a.m., the Board reconvened to open session.

Disclosure of reportable actions taken in Closed Session, pursuant to Government Code Section 54957.1: There were no reportable actions taken in closed session.

**ADJOURNMENT**

President Orvis adjourned the meeting at 11:01 p.m.

The next regular board meeting is scheduled for April 20, 2023, at the offices of South San Joaquin Irrigation District beginning at 9:00 a.m.

ATTEST:

\_\_\_\_\_  
Summer Nicotero, Secretary  
Tri-Dam Project

# BOARD AGENDA REPORT

Date: 4/20/2023  
Staff: Genna Modrell

---

**SUBJECT:** Tri-Dam Project March Statement of Obligations

---

**RECOMMENDED ACTION:** Recommend Approval of March Statement of Obligations

---

**BACKGROUND AND/OR HISTORY:**

Submitted for approval is the March Statement of Obligations for Tri-Dam Project.

**FISCAL IMPACT:** See Attachments

**ATTACHMENTS:** Tri-Dam Project Statement of Obligations

---

**Board Motion:**

**Motion by:** \_\_\_\_\_ **Second by:** \_\_\_\_\_

**VOTE:**

**OID:** DeBoer (Yes/No) Doornenbal (Yes/No) Orvis (Yes/No) Santos (Yes/No) Tobias (Yes/No)

**SSJID:** Holbrook (Yes/No) Kamper (Yes/No) Roos (Yes/No) Spyksma (Yes/No) Weststeyn (Yes/No)

# Tri-Dam Project

## Statement of Obligations

Period Covered

**March 1, 2023 to March 31, 2023**

**TRI-DAM PROJECT  
STATEMENT OF OBLIGATIONS  
Period Covered  
March 1, 2023 to March 31, 2023**

<b>One-Half Oakdale Irrigation District</b>	<b>\$ 575,107.43</b>
<b>One-Half South San Joaquin Irrigation District</b>	<b>\$ 575,107.44</b>
<b>Total Obligations</b>	<b><u>\$ 1,150,214.87</u></b>

**CERTIFICATION**

**OAKDALE IRRIGATION DISTRICT**

\_\_\_\_\_  
Thomas D. Orvis

\_\_\_\_\_  
Ed Tobias

\_\_\_\_\_  
Linda Santos

\_\_\_\_\_  
Herman Doornenbal

\_\_\_\_\_  
Brad DeBoer

**SOUTH SAN JOAQUIN IRRIGATION DISTRICT**

\_\_\_\_\_  
John Holbrook

\_\_\_\_\_  
Dave Kamper

\_\_\_\_\_  
David Roos

\_\_\_\_\_  
Glenn Spyksma

\_\_\_\_\_  
Mike Weststeyn

Each of the undersigned certifies that he is President or Secretary of his respective District;  
That the amounts designated above have been properly incurred as an obligation of the Tri-Dam Project; that  
checks for payment of said amounts have been drawn on a Tri-Dam Project account at Oak Valley Community  
Bank, Sonora, California.

**OAKDALE IRRIGATION DISTRICT  
PRESIDENT,**

\_\_\_\_\_  
Thomas D. Orvis

**SECRETARY,**

\_\_\_\_\_  
Scot A. Moody

\_\_\_\_\_  
Date

**SOUTH SAN JOAQUIN IRRIGATION DISTRICT  
PRESIDENT,**

\_\_\_\_\_  
Mike Weststeyn

**SECRETARY,**

\_\_\_\_\_  
Peter M. Rietkerk

\_\_\_\_\_  
Date

# Tri Dam Project Statement of Obligations

**Period Covered**  
**From To**  
March 1, 2023 to March 31, 2023

	<u>No. Chks.</u>	<u>Amount</u>
<b><u>Vendor Check Register Report</u></b> (Please see attached Check Listing)	99	\$820,729.84

**Payrolls - Net Charges**

<u>Pay Date</u>	<u>Type</u>	<u>Payroll Amount</u>	
2-Mar-23	Payroll	\$ 105,002.72	
16-Mar-23	Payroll	\$ 123,445.44	
31-Mar-23	Payroll	\$ 101,036.87	
Total Net Payroll		\$ 329,485.03	\$ 329,485.03

<b>Total Disbursements for the Period</b>	<b>\$1,150,214.87</b>
---	-----------------------

<b>Distribution Between Districts ~</b>	
Oakdale Irrigation District	\$ 575,107.43
South San Joaquin Irrigation District	\$ 575,107.44

<b>Total Districts</b>	<b>\$ 1,150,214.87</b>
------------------------	------------------------

# Project

## March Checks



Check Number	Vendor No	Vendor Name	Check Date	Description	Amount
129724	10183	Cal PERS S457 Plan	03/02/2023		825.00
129725	10815	Cal PERS System	03/02/2023	EE/ER Retirement Plan	17,377.09
129726	10811	IBEW	03/02/2023	EE Union Dues	1,278.55
129727	10812	Nationwide Retirement Solution	03/02/2023	EE Retirement Plan	3,706.26
129728	10012	ACE Hardware	03/06/2023		118.04
129729	10013	Acme Rigging and Supply Co. Inc.	03/06/2023	1/2 ton shackle, grader blades	2,476.57
129730	11086	Benefit Resource, LLC	03/06/2023		152.50
129731	11374	CA Dept. of Water Resources	03/06/2023	2022 Snow Survey	3,000.00
129732	10935	Data Path, Inc.	03/06/2023	Network Support	5,083.35
129733	10227	Del Oro Water Co. Inc.	03/06/2023		620.49
129734	10333	Grainger Inc. W. W.	03/06/2023		206.26
129735	11049	Hunt & Sons, Inc.	03/06/2023		466.01
129736	10966	Independent Electric Supply, Inc.	03/06/2023	Transformer	5,496.56
129737	10439	McMaster-Carr Supply Co.	03/06/2023		663.91
129738	11028	MHD Group, Inc.	03/06/2023		400.00
129739	10466	Mountain Oasis Water Systems & Btl Co L	03/06/2023		79.25
129740	10500	OID ~ Routine	03/06/2023	Admin / Finance Services	7,857.72
129741	11343	Tim O'Laughlin, PLC	03/06/2023	Legal Fees	37,665.00
129742	11011	Pacific Gas & Electric	03/06/2023		532.15
129743	10514	Pacific Gas & Electric Co.	03/06/2023	Utilities	5,951.27
129744	10933	Smile Business Products	03/06/2023		187.64
129745	10749	UPS	03/06/2023		46.44
129746	11426	Unico Mechanical Corp	03/06/2023	Beardsley PRV	252,521.27
129747	10866	AT&T Teleconference Services	03/14/2023		35.16
129748	10154	Calaveras Telephone Co.	03/14/2023		229.71
129749	10986	Cal-Waste Recovery Systems, LLC	03/14/2023		27.14
129750	10225	Debco Automotive Supply Inc.	03/14/2023	Batteries, filters, oil filter, DEF	3,106.52
129751	11441	Brad A. Dessert	03/14/2023	Tulloch Performance Deposit Refund	3,000.00
129752	10250	Downey Brand Attorneys LLP.	03/14/2023	Tulloch Litigation	3,799.31
129753	10289	Federal Energy Reg. Commission	03/14/2023	Annual ;and use fees	36,786.87
129754	10294	FISHBIO Environmental LLC	03/14/2023	Fish Studies	94,139.97
129755	10320	General Supply Co.	03/14/2023		717.70
129756	10358	HILTI Inc.	03/14/2023		121.06
129757	11049	Hunt & Sons, Inc.	03/14/2023	Fuel	21,334.96
129758	11440	JLK Enterprises	03/14/2023		679.47
129759	10399	JS West Propane Gas	03/14/2023		185.13
129760	10402	Kamps Propane	03/14/2023	Propane	3,083.09
129761	10879	Lowe's	03/14/2023		455.46
129762	10439	McMaster-Carr Supply Co.	03/14/2023		171.23
129763	10908	McMillen, LLC	03/14/2023	FERC Part 12D Inspections & Reporting	26,962.50
129764	10466	Mountain Oasis Water Systems & Btl Co L	03/14/2023		105.25
129765	11353	Nates Saw and Mower, LLC	03/14/2023		127.36
129766	11343	Tim O'Laughlin, PLC	03/14/2023	Legal Fees	3,005.00
129767	11389	Paris Kincaid Wasiewski	03/14/2023	Legal Fees	2,375.00
129768	10535	Pitney Bowes GFS LLC	03/14/2023		402.50
129769	11439	Prime Auto Glass	03/14/2023		160.00
129770	11414	Provost & Pritchard	03/14/2023	Hells Half Acre & Tulloch Spillway- Road Repairs Consulting	19,075.40
129771	11416	Ralph Andersen & Associates	03/14/2023	General Manager Recruitment	30,000.00
129772	11108	c/o MKI Reps Schweitzer Engineering Lab	03/14/2023	Power quality & revenue meter	6,385.52
129773	10904	Sonora Ford	03/14/2023		115.23
129774	10665	Staples	03/14/2023		488.59
129775	10718	Tractor Supply Credit Plan	03/14/2023		285.86
129776	10749	UPS	03/14/2023		128.65
129777	10771	W.D. Edwards Co. LLC	03/14/2023	Part 12D Reports	1,890.00
129778	10891	Wagner & Bonsignore Consulting Civil En	03/14/2023	Water Rights	1,593.75

129779	10776	Waste Mgmt of Cal Sierra Inc.	03/14/2023		438.87
129780	11442	Milliman Inc.	03/15/2023	GASB online tool	3,150.00
129781	10477	National Flooring & Supply	03/28/2023	GM House flooring	2,787.06
129782	10013	Acme Rigging and Supply Co. Inc.	03/28/2023		349.42
129783	11437	American Rescue & Safety LLC	03/28/2023	Fall Prevention Training - Lead Technician & Equipment Operator	2,500.00
129784	10067	AT&T - SBC - Pac Bell	03/28/2023	Telephone	5,638.10
129785	11428	Boutin Jones Inc.	03/28/2023	Legal Fees	1,384.50
129786	10204	Consolidated Electrical Dist.	03/28/2023		44.17
129787	10227	Del Oro Water Co. Inc.	03/28/2023		610.98
129788	10250	Downey Brand Attorneys LLP.	03/28/2023	Tulloch Litigation	3,273.62
129789	11388	Factory Technologies, Inc.	03/28/2023	Tech Support - Tulloch Dam	4,650.00
129790	10319	General Plumbing Supply Co Inc.	03/28/2023		640.95
129791	10333	Grainger Inc. W. W.	03/28/2023		501.43
129792	10358	HILTI Inc.	03/28/2023		412.97
129793	11049	Hunt & Sons, Inc.	03/28/2023		639.27
129794	10428	M C I	03/28/2023		15.86
129795	10466	Mountain Oasis Water Systems & Btl Co L	03/28/2023		58.75
129796	10467	Mouser Electronics Inc.	03/28/2023		852.53
129797	10513	Pacific Gas & Elec - Non Util	03/28/2023		168.28
129798	11004	Pacific Gas & Electric	03/28/2023		57.39
129799	11011	Pacific Gas & Electric	03/28/2023	Utilities	3,171.33
129800	10514	Pacific Gas & Electric Co.	03/28/2023	Utilities	6,248.04
129801	11160	Pape Machinery	03/28/2023	wire harness, flood lamps, hydraulic oil for JD Grader	4,499.76
129802	11274	PAR Environmental Services, Inc.	03/28/2023	HPMP Archaeological Monitoring	4,574.15
129803	10618	Sierra Motors	03/28/2023	Replace nox sensors 1 & 2	1,327.20
129804	10845	Sierra Office Supply & Printing	03/28/2023		148.80
129805	10904	Sonora Ford	03/28/2023		388.59
129806	11005	Sonora Lumber Company	03/28/2023		43.09
129807	10666	Star Microwave Service Corp.	03/28/2023	Goodwin microwave repair	3,110.25
129808	11258	Verizon	03/28/2023		178.04
129809	10778	Watermark Engineering Inc.	03/28/2023	Streamgaging	12,500.00
129810	11419	ZGlobal, Inc	03/28/2023	Power Purchase Consultant	42,780.00
129811	10813	ACWA Joint Powers Insurance Authority	03/16/2023	Health Benefits	51,390.29
129812	10183	Cal PERS S457 Plan	03/16/2023		825.00
129813	10815	Cal PERS System	03/16/2023	EE/ER Retirement Plan	17,387.22
129814	10811	IBEW	03/16/2023	EE Union Dues	1,287.76
129815	10812	Nationwide Retirement Solution	03/16/2023	EE Retirement Plan	3,840.38
129816	10900	Chase Cardmember Service	03/28/2023		6.92
129817	11435	VISA	03/29/2023	Buoy rope, meals, fuel, NWA Conference, travel, misc supplies, small tools	5,623.85
129818	10183	Cal PERS S457 Plan	03/29/2023	EE Retirement Plan	1,275.00
129819	10815	Cal PERS System	03/29/2023	EE/ER Retirement Plan	17,391.41
129820	10811	IBEW	03/29/2023	EE Union Dues	1,287.76
129821	10812	Nationwide Retirement Solution	03/29/2023	EE Retirement Plan	3,794.88
129822	10663	Standard Insurance Co.	03/29/2023	Short/Long Disability	1,791.25

Report Total: \$ 820,729.84

# BOARD AGENDA REPORT

Date: April 20, 2023  
Staff: Summer Nicotero

---

**SUBJECT: REVIEW AND TAKE POSSIBLE ACTION TO ADOPT A RESOLUTION FOR DESIGNATION OF BANK ACCOUNT SIGNATORIES FOR THE TRI-DAM PROJECT**

---

**RECOMMENDED ACTION:** Approve Adoption of the Resolution for Designation of Bank Account Signatories for the Tri-Dam Project on the Oak Valley Community Bank and the US Bank accounts

---

**BACKGROUND AND/OR HISTORY:**

The attached resolution is submitted for authorization of a new signatories and reaffirming prior signatories for the Oak Valley Community Bank and US Bank accounts held by the Tri-Dam Project.

The attached adds Vera Whittenburg, Finance Manager, Tri-Dam Project.

**FISCAL IMPACT:** None

**ATTACHMENTS:** Resolution TDP 2023-03, Designation of Bank Accounts and Signatories

---

**Board Motion:**

**Motion by:** \_\_\_\_\_ **Second by:** \_\_\_\_\_

**VOTE:**

**OID:** DeBoer (Yes/No) Doornenbal (Yes/No) Orvis (Yes/No) Santos (Yes/No) Tobias (Yes/No)

**SSJID:** Holbrook (Yes/No) Kamper (Yes/No) Roos (Yes/No) Spyksma (Yes/No) Weststeyn (Yes/No)



**TRI-DAM PROJECT  
Oakdale Irrigation District  
South San Joaquin Irrigation District**

**RESOLUTION NO. TDP 2023-03**

**DESIGNATION OF BANK ACCOUNTS AND SIGNATORIES**

**WHEREAS**, the Joint Board of Directors of said Tri-Dam Project desires that specific persons be authorized to deposit funds in and withdraw funds from said accounts, with the full power to endorse and sign documents required to accomplish such purposes.

**NOW THEREFORE, BE IT RESOLVED**, that the specific accounts referred to and the persons designated to sign on each of said accounts together with their respective official titles, are as follows:

**BANK:**           Oak Valley Community Bank (All accounts)  
                          US Bank (All accounts)

**CHECK SIGNATORIES:**

Peter M. Rietkerk, General Manager, South San Joaquin Irrigation District  
Scot A. Moody, General Manager, Oakdale Irrigation District  
Sharon Cisneros, Chief Financial Officer, Oakdale Irrigation District  
Sonya Williams, Finance and Administration Manager, South San Joaquin Irrigation District  
Summer Nicotero, General Manager, Tri-Dam Project  
Vera Whittenburg, Finance Manager, Tri-Dam Project

**BE IT FURTHER RESOLVED**, that two signatures from the “**CHECK SIGNATORIES**” listed above are required on checks.

**PASSED AND ADOPTED**, this 20th day of April 2023 by the following vote.

**OAKDALE IRRIGATION DISTRICT**

**SOUTH SAN JOAQUIN IRRIGATION DISTRICT**

**AYES:  
NOES:  
ABSTAIN:  
ABSENT:**

**OAKDALE IRRIGATION DISTRICT**

**SOUTH SAN JOAQUIN IRRIGATION DISTRICT**

\_\_\_\_\_  
Tom D. Orvis, President

\_\_\_\_\_  
Mike Weststeyn, President

\_\_\_\_\_  
Scot A. Moody, Secretary

\_\_\_\_\_  
Peter M. Rietkerk, Secretary

# BOARD AGENDA REPORT

Date: 4/20/23  
Staff: Summer Nicotero

---

**SUBJECT:** May Board Meeting

---

**RECOMMENDED ACTION:** Cancel the Regular May Meeting and Schedule a Special Meeting for Wednesday, May 17

---

**BACKGROUND AND/OR HISTORY:**

Our regularly scheduled May board meeting is set for Thursday, May 18. Due to several staff conflicts, Tri-Dam staff request that the Board consider canceling this meeting and scheduling a Special Meeting. Staff have proposed Wednesday, May 17<sup>th</sup> at the regular meeting time as a Special Meeting recommendation.

**FISCAL IMPACT:** None

**ATTACHMENTS:** None

---

**Board Motion:**

**Motion by:** \_\_\_\_\_ **Second by:** \_\_\_\_\_

**VOTE:**

**OID:** DeBoer (Yes/No) Doornenbal (Yes/No) Orvis (Yes/No) Santos (Yes/No) Tobias (Yes/No)

**SSJID:** Holbrook (Yes/No) Kamper (Yes/No) Roos (Yes/No) Spyksma (Yes/No) Weststeyn (Yes/No)

# BOARD AGENDA REPORT

Date: 4/20/23  
Staff: Summer Nicotero

---

**SUBJECT:** AB 1594 Letter of Support

---

**RECOMMENDED ACTION:** Authorize the General Manager to Sign a Letter of Support for AB1594

---

**BACKGROUND AND/OR HISTORY:**

Assembly Bill 1594, authored by Assembly Member Garcia, amends the Zero Emission Vehicle code requirements to allow a public agency to maintain water and electric reliability by recognizing the need to replace traditional specialized vehicles in a manner that supports their ability to provide reliable service and respond to major events.

Tri Dam has drafted a letter of support, indicating our need for traditional vehicles given our location, weather elements, and fire hazards. In addition, our county lacks the infrastructure required to support an electric fleet.

SSJID has also submitted a letter of support that mentions Tri Dam, bringing the interests of SSJID, OID and Tri Dam forward as a collective unit.

**FISCAL IMPACT:** None

**ATTACHMENTS:** AB 1594 Letter of Support

---

**Board Motion:**

**Motion by:** \_\_\_\_\_ **Second by:** \_\_\_\_\_

**VOTE:**

**OID:** DeBoer (Yes/No) Doornenbal (Yes/No) Orvis (Yes/No) Santos (Yes/No) Tobias (Yes/No)

**SSJID:** Holbrook (Yes/No) Kamper (Yes/No) Roos (Yes/No) Spyksma (Yes/No) Weststeyn (Yes/No)



# TRI-DAM PROJECT

of the South San Joaquin & Oakdale Irrigation Districts

Telephone: (209) 965-3996 • Fax: (209) 965-4235

---

4/20/2023

The Honorable Laura Friedman  
Chair, Assembly Transportation Committee  
1021 O St., Ste. 5740  
Sacramento, CA 95814

**Subject: AB 1594 (E. Garcia) Medium- and heavy-duty zero-emission vehicles: public agency utilities - Support**

Dear Chair Friedman,

The Tri Dam Project supports AB 1594 and applauds your leadership on the important issue. AB 1594 will ensure that publicly owned electric, water, and wastewater utilities have a pathway to procure zero-emission medium- and heavy-duty vehicles everywhere feasible, while maintaining the ability of publicly owned utilities to rely on their fleets to provide reliable service and respond to emergencies.

Our agency relies on highly specialized medium- and heavy-duty vehicles to respond to emergencies, restore service, and prevent disruptions. Tri Dam is a hydroelectric generator located in Tuolumne County. We work in rough, remote terrain in a region with little to no support for electric vehicles. The infrastructure required to support our fleet of heavy trucks, dump trucks, cranes, and snow removal equipment is non-existent. We monitor dams, reservoirs, hydroelectric generation turbines, power houses, and electric lines. In the event of an emergency we require the ability to respond to remote locations for extended periods of time, often in inclement weather. The vast majority of our facilities are located on forest roads in higher elevations in high fire risk areas.

The California Air Resources Board (CARB), pursuant to Governor Newsom's issued Executive Order N-79-20, is taking final action on a rule that would require publicly owned utilities to purchase 100% medium- and heavy-duty ZEVs starting in 2027. The rule would require a publicly owned utility such as ours to purchase a ZEV even in cases even where the utility can show with evidence that there is no ZEV commercially available or capable of meeting the utility's needs. Without providing reasonable flexibility, this rule would hamper the ability of our agency to maintain service, respond to emergencies, and provide mutual aid assistance when needed.

AB 1594 will help the state meet its ZEV goals in a manner that accounts for the essential services agencies like ours provide to our communities. The bill would ensure that regulations such as the CARB rule referenced above, consider both of the following:

- Recognize the diversity of fleet size, terrain, and climate, and authorize public agency utilities to purchase replacements for traditional utility specialized vehicles that are at the end of life when needed to maintain reliable service and respond to major foreseeable events, including, but not limited to, severe weather, wildfires, natural disasters, and physical attacks.

- In coordination with public agency utilities, include a list of vehicle vendors and suppliers that meet zero-emission vehicle standards and the public agency utilities' technical and performance requirements.

Thank you for authoring AB 1594. Please contact me at [snicotero@tridamproject.com](mailto:snicotero@tridamproject.com) with any questions about our position or our use of medium- and heavy-duty vehicles to uphold service reliability and to respond in emergencies.

Sincerely,

Summer Nicotero  
General Manager

Cc: The Honorable Chair and Members, Assembly Committee on Transportation

# BOARD AGENDA REPORT

Date: 4/20/2023  
Staff: Summer Nicotero

---

**SUBJECT:** Department of Water Resources Annual Dam Fees

---

**RECOMMENDED ACTION:** Discussion and possible action to approve the Department of Water Resources annual dam fees for 2023

---

**BACKGROUND AND/OR HISTORY:**

The Department of Water Resources' Division of Safety of Dams (DSOD) is funded solely through annual fees and application filing fees. These fees are assessed and collected to cover costs of the Program and are governed by Section 6307 of the California Water Code. The fees for Fiscal Year 2023/2024 billing cycle are \$313,903.

**FISCAL IMPACT:** \$313,903

**ATTACHMENTS:** DWR Invoice

---

**Board Motion:**

**Motion by:** \_\_\_\_\_ **Second by:** \_\_\_\_\_

**VOTE:**

**OID:** DeBoer (Yes/No) Doornenbal (Yes/No) Orvis (Yes/No) Santos (Yes/No) Tobias (Yes/No)

**SSJID:** Holbrook (Yes/No) Kamper (Yes/No) Roos (Yes/No) Spyksma (Yes/No) Weststeyn (Yes/No)



STATE OF CALIFORNIA  
 Department of Water Resources  
 P.O. Box 942836  
 Sacramento, CA 94236-0001

TRI-DAM PROJECT  
 2023 MAR 22 PM 1:27

**INVOICE**  
**Annual Dam Fee FY 23/24**

TRI DAM PROJECT  
 ATTN: GENERAL MANAGER  
 MR. JEFF SHIELDS  
 PO Box 1158  
 PINECREST CA 95364

ACCOUNT INFORMATION
Customer No.: 1027
Invoice Date: 03/13/2023
Invoice No.: 1800155404
Due Date: 07/01/2023

Dam Number	Dam Name	Rate Category	Amount
62.004	Beardsley	GENERAL RATE (ONE CAS)	\$101,259.00
62.007	Beardsley Afterbay	GENERAL RATE (NO CAS)	\$5,437.00
62.005	Donnells	GENERAL RATE (ONE CAS)	\$109,045.00
62.000	Goodwin	GENERAL RATE (NO CAS)	\$22,857.00
62.006	Tulloch	GENERAL RATE (ONE CAS)	\$75,305.00

**Message: Penalty and Interest may be imposed for fees received more than 30 days after the July 1, 2023 deadline. Currently the only payment form accepted is check and ACH/EFT.** **Total due: \$ 313,903.00**

For questions regarding payments, please contact DWR Accounting Office at (916)902-7113 or email [adf@water.ca.gov](mailto:adf@water.ca.gov).  
 For questions regarding the fee, please contact Division of Safety of Dams at (916)565-7800.

**REMIT SLIP**

**MAKE CHECK PAYABLE TO:**  
**Department of Water Resources**  
**DAM FEE**  
**P.O. Box 942836**  
**Sacramento, CA 94236-0001**

Invoice No.: 1800155404  
 Due Date: 07/01/2023  
 Customer No.: 1027  
 Total due: \$313,903.00

Your Payment:

**FEE INFORMATION**

Effective June 27, 2017, Senate Bill 92 modified Section 6307 of the California Water Code. In part this section stipulates that: The Department of Water Resources (DWR) shall adopt, by regulation, a schedule of fees to cover DWR's reasonable regulatory costs in carrying out the supervision of dam safety. Please refer to Division of Safety of Dams Annual Fee Schedule for Fiscal Year 2023/2024.

Annual fees are due on or before July 1, 2023, and, in accordance with Water Code Section 6307(b), penalty and interest may be imposed for fees received more than 30 days after the July 1, 2023. Delinquent payments are subject to a 10% penalty, plus interest at the rate of 0.5% per month (Water Code Section 6428(b)). If making payment by ACH or EFT, please contact DWR for banking details at [cash@water.ca.gov](mailto:cash@water.ca.gov).

**CHANGE OF MAILING ADDRESS**

County of Residence: \_\_\_\_\_

Street Number: \_\_\_\_\_ Street Name: \_\_\_\_\_ Apartment #: \_\_\_\_\_

City: \_\_\_\_\_ State: \_\_\_\_\_ Zip Code: \_\_\_\_\_



# BOARD AGENDA REPORT

Date: 4/20/2023  
Staff: Chris Tuggle

---

**SUBJECT: Donnells Dam Emergency Generator Replacement**

---

**RECOMMENDED ACTION: Replace the Donnells Dam emergency generator.**

---

**BACKGROUND AND/OR HISTORY:**

Donnells Dam has no grid tie power. Thus, the 45kW engine driven generator is utilized for supplying power to operate the spill gate hoist and bypass valves. The generator is also critical in maintaining the communications and security systems as it is also used to charge the battery bank when needed. The generator no longer has parts support. Energy Systems is the sole source provider for this generator as they are the West Coast Distributor for all Commercial and Industrial Generac products.

**Equipment and/or Parts Needed:** 50kW Generac Generator, LP Fuel – \$29,800  
Mounting Brackets, Exhaust, Ducting, Plumbing - \$4,000

**FISCAL IMPACT:** Budget \$45,000

**ATTACHMENTS:** SG50 Generator Quote - \$36,251 including tax and shipping

---

**Board Motion:**

**Motion by:** \_\_\_\_\_ **Second by:** \_\_\_\_\_

**VOTE:**

**OID:** DeBoer (Yes/No) Doornenbal (Yes/No) Orvis (Yes/No) Santos (Yes/No) Tobias (Yes/No)

**SSJID:** Holbrook (Yes/No) Kamper (Yes/No) Roos (Yes/No) Spyksma (Yes/No) Weststeyn (Yes/No)



**Date:** March 29, 2023

**To:** Tri Dam Project

**Attn:** Rich Ennis

**Reference:** Donnells Dam Project

Energy Systems is pleased to offer the following proposal:

**Scope of Supply:**

Quantity 1 - Generac Industrial gaseous engine-driven generator, 4.5L in-line 4 cylinder engine, consisting of the following features and accessories:

- Stationary Emergency-Standby rated
- 50 kW rating, wired for 120/208 VAC three phase, 60 Hz
- With upsized 80kW alternator
- Brushless Excitation
- MLCB, 80% rated thermal-magnetic
  - 200 Amp
- LP Vapor fuel system
- No enclosure (open set)
- EPA Certified
- Ultra-Low Emissions
- cETLus
- Power Zone Pro Digital Control Panel for Single Generators
  - Meets NFPA 99 and 110 requirements
  - Temp Range -40 to +60 degrees C
  - Humidity 2 – 95% (Non Condensing)
  - UL6200
  - C-ETL-US
  - CE
  - IEC801 (Radiated Emissions, Susceptibility, and Surge Immunity)
  - 4.3” Resistive Color Touchscreen
    - Webserver (via Power Zone Gateway using ethernet)
    - IP65 (front)
    - Auto/Manual/Off key switch, Alarm Indication, Not in Auto Indication, audible alarm, emergency stop switch
  - Dual Core Digital Microprocessor

- RS485, Ethernet and CANbus ports
- All engine sensors are 4-20ma for minimal interference
  - Sensors: Oil Pressure, optional Oil Temp, Coolant Temp and Level, Fuel Level/Pressure (where applicable), Engine Speed, DC Battery Voltage, Run-time Hours, Generator Voltages, Amps, Frequency, Power, Power Factor
  - Alarm Status: Low or High AC Voltage, Low or High Battery Voltage, Low or High Frequency, Pre-low or Low Oil Pressure, Pre-high or High Oil Temp (optional), Low Water Level and Temp, Pre-high or High Engine Temp, High, Low, and Critical-low Fuel Level/Pressure (where applicable), Overcrank, Over and Under Speed, Unit Not in Automatic
  - Programmable I/O
  - Built-in PLC for special applications
- Engine function monitoring and control:
  - Full range standby operation; programmable auto crank, Emergency Stop, Auto-Off-Manual switch
  - Isochronous Governor
    - 0.25% digital frequency regulation with: soft-start ramping - adjustable, gain - adjustable, overshoot limit - adjustable
  - 3 Phase RMS Voltage Sensing
    - +/-0.5% digital voltage regulation with: soft-start voltage ramping - adjustable, loss of sensing protection - adjustable, negative power limit - adjustable, Hi/Lo voltage limit - adjustable, V/F slope and gain - adjustable, fault protection
- Service reminders, trending, fault history (alarm log)
- I2T function for full generator protection
- Selectable low-speed exercise
- 2-wire start controls for any 2-wire transfer switch
- Remote Emergency Stop Switch, Surface-Mount, shipped loose
- 110 AH, 925 CCA Group 31 Battery, with rack, installed
- Block Heater, 1500 watt
- 2-Stg Heavy Duty Air Cleaner
- Battery Charger, 10 Amp, NFPA 110 compliant, installed
- 120V GFCI and 240V Outlet
- Engine Run Relay, 10 Amp
- Fan and Belt Guards
- Flex Fuel Hose, shipped loose
- Critical Grade Silencer
- Std set of 3 Manuals
- Premium 10-Year Comprehensive Warranty
- SG0050GG264.5V18TBNLC

**Pricing:**

<b>SG50 Generator Pricing .....</b>	<b>\$ 27,400.00</b>
<b>Start Up &amp; Training .....</b>	<b>\$ 2,400.00</b>
<b>Total Package Price .....</b>	<b>\$ 29,800.00</b>

**Optional Adders:**

- 10 year Extended Warranty ..... \$ Included
- Annual PM ..... \$ 1,080.00
- Remote Emergency Stop button (surface mount) ..... \$ Included
- Remote Annunciator ..... \$ 750 per unit

**Shipping:**

Estimated lead time from factory, excluding transit: 30-38 Weeks ARO.

**Scope Clarifications:**

- Estimated Submittal Lead time: 5-7 business days.
- No equipment will be ordered without written release to proceed – price changes issued by the manufacturer after quotation validity and prior to release will be passed along to the customer.
- Pricing includes freight to site.
- If transfer switch needs to be shipped separately, additional freight charges will apply.
- Pricing for adders purchased separately from equipment will be assessed at time of purchase.
- Installation, fueling and termination of connections not included.
- Installation and mounting of exhaust not included.
- The Energy Systems provided start-up checklist and supporting pictures must be received by Supplier two weeks prior to technician scheduling.
- All industrial products require a formal start up by a Generac factory certified technician.
- Pricing is based on work being completed during regular business hours.
- Load bank (if included) is resistive load.
- Training to be completed same day as start up. Additional charges will apply if a separate trip is required.
- Enclosure color is Generac Industrial grey. Custom colors can be quoted separately.
- Not included unless otherwise noted: equipment offloading, installation, fuel, permits, signage, taxes, exhaust system backpressure test, exhaust emissions test, infrared scanning, NETA testing, harmonic testing, concrete pad, anchoring, fuel pipe, exhaust pipe, pipe insulation, Building communication integration, license fees.

**Other Terms and Conditions:**

1. Offer Validity: 30 days.
2. Payment terms:

***Customers with credit***

10% deposit due at time of order, balance invoiced at shipment with NET 30.

***Customers without credit***

25% deposit due at time of order, 70% due prior at shipment readiness, 5% due at start-up.

3. Credit is subject to approval by Energy Systems upon receipt of business credit application.
4. Incoterms: ExWorks factory with freight allowed to the jobsite, on a truck, curbside.
5. Manufacturer lead time to be confirmed upon approved release for production letter and receipt of a West Coast Energy Systems approved purchase order.
6. Equipment cannot be held by Energy Systems or its suppliers without prior written agreement.
7. Any sale of goods or services, and any extension of credit, is governed by and subject to West Coast Energy Systems' Terms and Conditions of Sales and Service ("Terms") located at <https://energysystems.com/terms-and-conditions-of-sale-and-service/> which is incorporated by reference. The Terms are subject to change at any time and you are advised to frequently re-review the Terms. Unless pursuant to a written agreement mutually executed by both parties, the Terms shall be binding upon the parties, and any other terms, communications or documents are to be disregarded and hereby expressly rejected.

**Sincerely,**

Ryan Fields  
West Coast Energy Systems  
(209) 840-0573

# BOARD AGENDA REPORT

Date: 4/20/23  
Staff: Chris Tuggle

---

**SUBJECT:** Replace the Beardsley Powerhouse Raw Water Tank Roof

---

**RECOMMENDED ACTION:** Approve the quote from Up Yurts for a water tank roof for BPH.

---

**BACKGROUND AND/OR HISTORY:**

The roof of the Beardsley Powerhouse raw water tank has been identified by Tri-Dam's insurance company as needing repairs to ensure the integrity of the raw water tank. During the March 2023 snowstorms, the original wood roof collapsed into the tank. Tri-Dam employees removed the debris and temporarily returned the water tank to service, but a roof is still needed. This engineered 7/12 pitch roof kit is pre-fabricated and snow load rated. Manufacturer states a 70-year life expectancy. The other roof suppliers have their roofs manufactured by Up Yurts so additional quotes will be the same or higher. Sourcewell was investigated and no suppliers were identified.

**FISCAL IMPACT:** Budget – \$100,000                      GL Code 1-8-21-07-69907

**ATTACHMENTS:** Up Yurts Roof Quote - 21" Metal Roof Kit                      \$12,281

---

**Board Motion:**

**Motion by:** \_\_\_\_\_ **Second by:** \_\_\_\_\_

**VOTE:**

**OID:** DeBoer (Yes/No) Doornenbal (Yes/No) Orvis (Yes/No) Santos (Yes/No) Tobias (Yes/No)

**SSJID:** Holbrook (Yes/No) Kamper (Yes/No) Roos (Yes/No) Spyksma (Yes/No) Weststeyn (Yes/No)

**UpYurts**  
 30 Crispell Ln  
 New Paltz, NY 12561 USA  
 Matthew Rogers  
 845-384-2994  
 ultralightyurts@gmail.com

# Invoice

Invoice Number: 230404

Invoice Date: 04/04/2022

Billing Address:		Shipping Address:
Company:	Tri Dam Project	Company:
Name:	Rich Ennis	Name:
Address:	31885 Old Strawberry Rd.	Address:
City/State/Zip:	Strawberry, CA 95375	City/State/Zip:

Customer Phone : 209-559-4963

rennis@tridamproject.com

**Order Information:**

Qty	Product Description	Amount Each	Amount
1	21' Metal Yurt Roof package	7232.50	7232.50
1	Tension Band for 30 psf snow load	975.21	975.21
24	Roof Rib Stiffeners for 30 psf snowload	53.13	1275.12
			9482.83

Tax:	853.45
Shipping:	1944.78
<b>Grand Total:</b>	12,281.06
Deposit 50% Due at start	6140.53
Balance due at delivery	6140.53
<b>Total Due Today</b>	<b>6140.53</b>

Sales Tax exemption can be provided to remove sales tax.

Customer Responsible for unloading LTL freight truck at delivery location.

Notes:
Sales tax applies unless buyer has a valid NYS sales tax exemption and provides the form within 90 days or item is shipped out of state. Signature of Buyer _____

**Additional Information:**

**1 - Work to be Done.** BUYER as noted above commissions Clean Air Yurts and Woodworks LLC, herein known as UP YURTS to perform work described above and any options as described above. There shall be no required completion date unless otherwise specified in this agreement. BUYER certifies that the work was performed for the costs listed above.

**2 - Payment for Work.** BUYER agrees to pay UP YURTS a deposit upon execution of this Agreement, with the balance due no later than the final completion date of the project. Custom projects valued under \$1500 are subject to payment in full at time of agreement. No returns on prototypes, samples, or custom work. If Buyer notifies UP YURTS to stop work, Buyer is responsible for the full cost of this agreement. BUYER agrees that under no circumstance will the buyer attempt any form of credit chargeback or attempt to recover their costs, unless agreed to by UP YURTS and BUYER. Shipping fees are non-refundable for any reason and any return shipping will be paid by BUYER.

**3 - Acceptance.** This Agreement will not become binding upon UP YURTS and BUYER until it is executed and accepted, either in paper or electronically by both the customer and UP YURTS, and not prior to UP YURTS receiving at least a 50% deposit. Prices are valid only for 30 days from the creation of a quote. Payment of a deposit after receiving this document electronically or in print is considered to be execution and acceptance in full by the BUYER, with or without signature.

**4 - Modification of the Agreement.** This Agreement can only be modified in writing, signed by both BUYER and UP YURTS, and specifically referring to this Agreement by this date. There are no other agreements, written or oral (except this Agreement), that apply to the work to be performed under this Agreement.

**5 - Change in Scope.** If the scope of the work changes from that estimated by UP YURTS, due to factors not known at the time of executing the Agreement, BUYER is responsible for all additional costs associated with those changes.

**6 - Tax.** Sales tax is not included in UP YURTS prices and is additional where applicable. Sales tax will apply for all purchases picked up by BUYER in New Paltz, NY.

**7 - Liability.** BUYER agrees to hold harmless and release from all liabilities UP YURTS for any and all damages resulting from use of the products to include, but not be limited to, personal injury during setup, take down and use of the products, improper setup, breakage during normal use, collapse of the products, fire, pests, and any other possible occurrences not listed here. Products are not structurally tested and carry no claims to their ultimate strength or durability. Products are not to be used for permanent occupation, unless approved by a third party agency. Products may burn even if treated to be fire-resistant. Keep all sources of flame away from flammable materials. Products made from natural wood and may contain defects not seen on the outside. BUYER to take responsibility for setup of the product, maintaining its integrity, inspecting for damage, and discontinuing use in cases of damage or degradation.

**8- Transportation.** BUYER to designate a preferred shipping carrier in advance of shipment. If BUYER does not designate a shipping carrier, UP YURTS will designate one on behalf of BUYER without accepting responsibility for expense or time. Shipments will be FOB New Paltz, NY.

**9 - Attorney Fees and Costs.** If UP YURTS incurs attorney fees and/or costs to enforce any part of this Agreement, BUYER agrees to cover those costs.

**10 – Both parties agree that any and all disputes arising from this agreement will be settled in the courts of Gardiner, NY or Ulster County, NY.**

Signature of Buyer \_\_\_\_\_



## *ROOF SPECIFICATIONS*

1. Roof sheets are triangular sections of galvanized steel, with raised ribs along each side, flat area between ribs, and 90° formed drip edge at the eave.
2. All roofs 12' (3.66 m) diameter through 42' (12.80 m) diameter shall have a single stage self-supporting roof. These roofs have a peak equipment load rating of 2,000 pounds (907 Kg). Roof pitch is 30°.
3. Roofs 48' (14.63 m), 54' (16.46 m), 60' (18.29 m), 72' (21.95 m), 78' (23.77 m), 90' (27.43 m) and 105' (32 m) diameter shall have a two-stage roof supported by "C" shaped, roll formed galvanized rafters and purlins. Peak equipment load rating is 10,000 pounds (4,500 kg). Roof pitch is 30°.
4. Roofs 12' (3.66 m) through 24' (7.32 m) diameter shall have 24 roof panels. Roof rib shall consist of a formed box-type rib with 3-1/4" (82 mm) rise above flat area.
5. Roofs 27' (8.23 m) through 42' (12.80 m) diameter shall have 36 roof panels, with formed box-type ribs. Roof rib height to be 3-1/4" (82 mm).
6. Roofs of 39' (11.89 m) and 42' (12.80 m) diameter shall have a tubular support ring with expandable connectors attached to the exterior of the roof midway between the eave and the segment ring. Purpose of the support ring is to provide added strength for roof construction. These roofs are also equipped with 36 roof rib supports.
7. All roof panels will be connected to the eave of the building with two rib clips and varying numbers of center clips, depending upon the diameter. Holes in top ring starter strips are factory punched for clip installation. Roofs used solely as a roofing material and relying on a structural rafter system do not need eave clips. Roof panels should be fastened to the rafters using appropriate fasteners depending on loads and rafter materials.
8. Each roof 12' (3.66 m) diameter and larger may optionally have one panel equipped with factory installed hinged inspection hatch and latch. Roof inspection hatch is located at the eave next to the roof ladder. Manhole is trapezoidal-shaped with dimensions 17" x 20" x 24" (430 mm x 508 mm x 610 mm).
9. Optional roof ladder cleats extend from eave to center fill cap. Ladder cleats consist of galvanized steel cold-formed angles of varying lengths bolted to top of one roof panel.
10. Center opening of 22" (560 mm) diameter roofs 12' (3.66) m to 24' (7.30 m) diameter. Roofs 27' (8.23 m) through 105' (32 m) diameter have a 36" (990 mm) diameter opening.
11. Optional steps consisting of galvanized steel cold-formed angles may be bolted to roof ribs around the perimeter of the center opening. Roof safety rings are available as an optional item.
12. Roof slopes at 30° angle from horizontal for all models.

# BOARD AGENDA REPORT

Date: 4/20/2023  
Staff: Chris Tuggle

---

**SUBJECT: Strawberry Forklift**

---

**RECOMMENDED ACTION: Approve the quote to purchase a new forklift.**

---

## BACKGROUND AND/OR HISTORY:

Strawberry is the most frequently used shipping destination for Tri-Dam Project as it is the only location staffed 24hrs a day and the reporting location the majority of the year. Due to amount of use needed and multiple personnel operating it, the Strawberry forklift should be the safest and most reliable machine. With no forklift in Tulloch, a Class A driver and equipment must be utilized to transport the forklift from Beardsley Service Center all the way to Tulloch for use as the Strawberry forklift is unsafe to load onto the trailer. The replacement forklift for Strawberry will have the added safety/convenience of integrated side shift, 700 lb. increase in lifting capacity and longer forks. With a new forklift in Strawberry the current one could be permanently relocated to Tulloch, all locations would have a forklift and transportation between facilities would not be required.

Staff recommends purchasing two spare cylinders at an estimated cost of \$350 each plus tax.

Staff recommends approving \$37,300 to purchase the forklift and two additional cylinders.

**Fiscal Impact:** Budget \$40,000

<b>ATTACHMENTS:</b>	Pape Quote	\$36,450.83 including tax & delivery
	Engineering Products Quote	\$37,282.25 including tax & delivery
	Next Level Warehouse Solutions Quote	\$37,564.66 including tax & delivery

---

## Board Motion:

**Motion by:** \_\_\_\_\_ **Second by:** \_\_\_\_\_

## VOTE:

**OID:** DeBoer (Yes/No) Doornenbal (Yes/No) Orvis (Yes/No) Santos (Yes/No) Tobias (Yes/No)

**SSJID:** Holbrook (Yes/No) Kamper (Yes/No) Roos (Yes/No) Spyksma (Yes/No) Weststeyn (Yes/No)



PAPE MATERIAL HANDLING  
 2410 GRAND AVENUE  
 SACRAMENTO, California 95838  
 Phone: 916-641-3434



### MODEL: GP050UX

All trucks shown with optional equipment. Please refer to quotation specifications.

## CUSTOMER DETAILS

CUSTOMER	Tri-Dam Project		
ADDRESS	31885 Old Strawberry Road Strawberry, California 95375		
SHIP-TO ADDRESS	31885 Old Strawberry Road Strawberry, California 95375		
CONTACT NAME	Rich Ennis		
PHONE	+1 209-965-3996		

PROPOSED BY	Paul Britton	TITLE	Territory Manager
PHONE	209-531-8588	EMAIL	pbritton@papemh.com

DATE	2023-04-10	QUOTE EXPIRATION	2023-05-10
------	------------	------------------	------------



PAPE MATERIAL HANDLING  
 2410 GRAND AVENUE  
 SACRAMENTO, California 95838  
 Phone: 916-641-3434



## Quoted Model: GP050UX Available Features

Yale® GP050UX Lift Truck - 5,000 lb Nominal Capacity, Class V

### Proposal Summary

Included Items	Description	Quantity
Model	Yale® GP050UX Lift Truck - 5,000 lb Nominal Capacity, Class V	1
Construction	Key Switch Start	
Powertrain	<p>PSI 2.4L LPG EPA/CARB emissions certified engine with electronic fuel injection provides outstanding fuel economy and performance in a heavy-duty industrial grade design. Features two (2) individual performance modes to optimize productivity and fuel economy.</p> <p>Self energizing drum brakes provide excellent stopping power with minimal brake pedal effort.</p> <p>Electronically Controlled Powershift 1 Speed Transmission provides smooth directional changes for greater operator productivity, along with electronic inching, which eliminates the costs of inch/brake adjustments</p>	
Powertrain Options	<p>High Air Intake</p> <p>Counterweight rear exhaust exits through counterweight opening to reduce turbulence and dust.</p> <p>Swing out and rotating LPG Tank Bracket with Twin Metal Strap</p> <p>Counterweight Net</p>	
Powertrain Accessories	Prevents operation of the hydraulic system if the operator is not in the proper operating position. Also disables directional travel on Internal Combustion Engine (ICE) trucks.	
Mast	<p>3 Stage Full Free Lift Mast 189" Maximum Lift Height, 85" Lowered Height</p> <p>Mast Tilt - 6° Forward / 6° Back</p>	
Carriages & Attachments	<p>41" Hook Type Integral Sideshift Carriage</p> <p>37" High Load Backrest</p>	
Forks	48" Hook Type (1.6" x 4.8") Standard Tapered Forks	
Hydraulics	<p>3 Function (1 Auxiliary) Hydraulic Control Valve</p> <p>Cowl mounted mechanical lever hydraulic controls are conveniently located.</p>	
Hoses	1 Auxiliary Function Hose Group - 2 Hoses Internally Mounted	
Wheels & Tires	<p>7.00 x 12-12 PR Pneumatic-Shaped Solid Drive Tires (Standard Tread)</p> <p>6.00 x 9-10 PR Pneumatic-Shaped Solid Steer Tires</p>	
Operator Compartment	<p>86" High Overhead Guard</p> <p>Rear drive handle with horn button is mounted on the right side of the truck behind the operator to enhance operator comfort while driving in reverse. The ergonomically angled handle features a thumb-operated horn button to allow the operator to keep their left hand on the steering wheel and in control of the truck while sounding the horn to alert other trucks or pedestrians.</p>	
Directional Control	<p>Lever Shift Direction Control - Mounted on Left Hand Side of Steering Column</p> <p>Steering wheel with integral spinner knob to enhance operator comfort and control.</p>	



PAPE MATERIAL HANDLING  
 2410 GRAND AVENUE  
 SACRAMENTO, California 95838  
 Phone: 916-641-3434



Seat	Full Suspension Vinyl Seat (SC29) with Switch for OPS  Our No-Cinch ELR (Emergency Locking Retractor) seat belt system moves with the operator and improves operator comfort and safety without cinching, especially when driving in reverse. It locks only when necessary to assist in operator safety.
Lights & Alarms	Two Front LED Work Lights with Stop, Tail, Indicator, and Reverse Lights  Audible Alarm - Reverse Direction Activated  Visible Alarm - Amber LED Strobe - Keyswitch Activated - Does Not Increase Truck Height
Warranty	12 Months / 2,000 Hours Manufacturer's Warranty, 36 Months / 6,000 Hours Powertrain Warranty; please see full Warranty Statement for additional details.
Literature & Nameplate	English Literature Pack and Labels
Fees & Surcharges	Freight  Fees & Surcharges  Destination Charge

## Additional Items or Accessories Included

	Description	Quantity
PKB	Pre-Delivery Inspection & Prep	1
PKB	Local Delivery	1

## Total Investment

<b>Price GP050UX</b>	\$33,986.79	<b>Qty: 1</b>	
<b>Quoted Quantity</b>	1	<b>TOTAL:</b>	\$33,986.79

F.O.B. Factory (factory freight not included). Price is exclusive of any taxes. Due to volatility of supply chain, transportation, lead times etc., we reserve the right to revise our pricing in direct correlation to price surcharges/increases received from the OEM. Lease payment quotes are subject to possible interest rate indexing at time of delivery. This sales order/proposal is subject to Pape' Material Handling's Terms and Conditions of Sale effective on the date hereof, which are incorporated in full by this reference. The Terms and Conditions of Sale are available at [www.pape.com/terms](http://www.pape.com/terms), and will also be sent by mail or email to Buyer upon request.

<b>Proposal By:</b>	Paul Britton	<b>Accepted By:</b>	
	_____		_____
<b>Signature:</b>		<b>Signature:</b>	
	_____		_____
<b>Date Signed:</b>		<b>Date Accepted:</b>	
	_____		_____
		<b>PO Number:</b>	
			_____



55 S. Display Way  
Sacramento, CA 96538  
(209) 914-4180

April 11, 2023

Rich Ennis  
Tri-Dam Project  
31885 Old Strawberry Road  
Strawberry, CA 96375

Mr. Ennis,

Thank you for the opportunity to provide the following new equipment quotation:

**Make:** Yale                      **Model:** GP050UX                      **Serial Number:** A7S1A06731W

**Year:** 2023                      **Hours:** 0                      **Unit Number:** E25540 / 82838C

**Specifications:**

**Upright:** 189" 3' Stage  
**Engine:** PSI 2.4 LP  
**Carriage:** Integral Side Shift  
**Hydraulics:** 3x3 with cowl levers  
**Tires:** Pneumatic Shaped Solid



Price: \$34,762.00 (Plus Tax)

**Full Payout Lease, W/ 1<sup>st</sup> payment upon delivery**

<b>Term</b>	<b>Total Monthly Payment</b>
<b>24 Months</b>	<b>\$ N/A</b>
<b>36 Months</b>	<b>\$ N/A</b>
<b>48 Months</b>	<b>\$ N/A</b>

*This proposal is valid for 30 days and is subject to availability*

Sincerely,

PO# \_\_\_\_\_

Date \_\_\_\_\_

Thomas Weaver  
Warehouse Systems Specialist  
Engineered Products  
(209) 941-4180

Signature \_\_\_\_\_

# TERMS AND CONDITIONS OF SALE

**TERMS AND CONDITIONS OF SALE:** Offers of sale are based on the terms and conditions stated herein. Unless otherwise provided on the face hereof, offers are good for acceptance for a period of 30 days from the date hereof. An order by the Buyer shall constitute an acceptance of the terms and conditions herein proposed. If, and only if, no offer of sale is issued by Seller, then the invoice shall be deemed: an acceptance of the Buyer's order; a written confirmation; and a final, complete, and exclusive written expression of the agreement between Seller and Buyer. Buyer is hereby notified that additional or different terms from those contained herein are objectionable.

- 1. Prices.** Prices quoted by Seller are subject to change without notice. Seller's prices in effect at the date of delivery will govern at Seller's option. Buyer shall pay all local, state, and federal taxes arising from or related to any sale or lease to which this document relates, except for taxes upon or measured by net income of Seller.
- 2. Delivery.** Stated or promised delivery dates are estimates only based upon Seller's best judgment and Seller shall not be responsible for deliveries later than promised regardless of the cause. Delivery periods are projected from the date of receipt of any order by Seller, but if equipment to be furnished by Seller is to be manufactured specifically to fill a particular order, delivery periods will be projected from the date of Seller's receipt of complete manufacturing information. If the furnishing of equipment on orders accepted by Seller is hindered or prevented by public authority or by the existence of war or other contingencies, including, but not limited to, shortage of materials, fires, labor difficulties, accidents, delays in manufacture or transportation, acts of God, embargoes, inability to ship, inability to insure against war risks or substantially increased prices or freight rates, or other causes beyond Seller's control, the obligation to fill or complete such orders shall be excused by Seller's option.
- 3. Transportation and Claims.** Prices quoted are net F.O.B. point designated in writing by Seller. When no F.O.B. point is designated in writing by Seller, prices for new articles shall be deemed to be net F.O.B. point of manufacture and prices for all other articles shall be deemed to be F.O.B. Seller's place of business at which the order for the articles is accepted. When transportation is allowed, the price charged will be adjusted to reflect the lowest transportation rates in effect at the time of shipment even though such rates may differ from those quoted by Seller. Seller's responsibility for the articles shall cease and all risk of loss shall become the Buyer's upon delivery of the articles to the first carrier for shipment to the Buyer or his consignee, even though such delivery shall be made prior to the arrival of the articles at the F.O.B. point designated, and any and all claims for shortages, deliveries, damages or non-delivery must be made by the Buyer or his consignee to the carrier. Seller shall in no event be responsible for shortages in shipments unless notice of such shortage is given in writing to Seller within 15 days after receipt of shipment.
- 4. Payment and Security.** Buyer agrees to pay in full for the equipment at time of delivery. Buyer agrees to pay the late charge on any past due balance at the rate of 18% per annum. The signator warrants that he/she has authority to execute this order on behalf of any party for whom he/she signs, and that such party has the power to enter into this agreement and perform its terms. As security for all of Buyer's obligations to Seller, Buyer grants to Seller a security interest in the equipment and authorizes Seller to file all documents necessary to perfect Seller's security interest. The security interest granted hereunder is in addition to any other rights available to Seller, and Seller shall have all of the rights and remedies available to a secured party under the Uniform Commercial Code, all of which are cumulative. Throughout the duration of Seller's security interest, Buyer shall keep the equipment fully insured against theft and loss or damage by fire and other casualty.
- 5. Buyer to Furnish.** Performance by Seller is subject to the Buyer furnishing a satisfactory credit rating certificate, letter of credit, evidence of financing, or any other similar papers necessary for the satisfactory completion of such order.
- 6. Laws Governing.** All orders will be governed by the laws of the State of Oregon.
- 7. Assignment.** The right to any monies due or to become due hereunder may be assigned by Seller, and Buyer upon receiving notice of such assignment, shall make payment as directed.
- 8. Limitations of Warranties.** If "NEW" warranty is indicated on the reverse side or if new equipment is purchased hereunder, all warranties are strictly given only by the manufacturer. Copies of manufacturer's warranty can be obtained from Seller. If "USED" warranty is indicated on the reverse side, Seller hereby warrants to Buyer that the equipment or components thereof designated on the reverse side, shall be free under normal use and service from defects in material and workmanship for the period shown, commencing on the date of delivery. Buyer's exclusive remedy for breach of the limited warranty shall be the repair or replacement of the warranted equipment without charge to Buyer when returned at Buyer's expense to the Seller's facility where the equipment was purchased, with proof of purchase. Buyer must give notice of any warranty claim not later than 7 days after the expiration of the warranty period and must return the equipment to Seller for repair or replacement no later than 30 days after expiration of the warranty period. Any action against Seller for breach of the limited warranty must be commenced within one year after the date of delivery of the equipment. Seller's warranty does not extend to any defect, claim, or damage attributable to the failure to operate and /or maintain the equipment in accordance with the manufacturer's specifications, or due to the failure to operate or maintain the equipment in accordance with any recommendations of Seller. If "AS IS" is indicated on the reverse side, no warranty of any kind is being given and the equipment is being sold with all faults. **THE WARRANTIES IN THIS PARAGRAPH AND ON THE REVERSE SIDE ARE THE EXCLUSIVE WARRANTIES GIVEN BY SELLER AND SUPERCEDE ANY PRIOR, CONTRARY, OR ADDITIONAL REPRESENTATIONS, WHETHER ORAL OR WRITTEN. SELLER HEREBY DISCLAIMS AND EXCLUDES ALL OTHER WARRANTIES, WHETHER EXPRESS, IMPLIED, OR STATUTORY, INCLUDING THE IMPLIED WARRANTIES OF MERCHANTABILITY OR FITNESS FOR A PARTICULAR PURPOSE, AND ANY IMPLIED WARRANTIES OTHERWISE ARISING FROM COURSE OF DEALING OR USAGE OF TRADE. SELLER SHALL NOT BE LIABLE FOR ANY LOSS, INJURY, OR DAMAGE TO PERSONS OR PROPERTY RESULTING FROM THE FAILURE OR DEFECTIVE OPERATION OF THE EQUIPMENT; NOR WILL SELLER BE LIABLE FOR DIRECT, INDIRECT, SPECIAL, INCIDENTAL, OR CONSEQUENTIAL DAMAGES OF ANY KIND SUSTAINED FROM ANY CAUSE.** This exclusion applies regardless of whether such damages are sought for breach of warranty, breach of contract, negligence, or strict liability in tort or under any other legal theory.
- 9. Attorneys Fees.** In the event suit or action is instituted against Buyer on account of or in connection with or based upon the terms hereof, the Buyer agrees to pay, in addition to the costs and disbursements provided by law, such sum as the court may adjudge reasonable attorney's fees in both the trial and appellate courts, or in connection with any bankruptcy proceeding.
- 10. Entire Agreement.** The foregoing shall constitute the complete and exclusive agreement between the parties, and it is expressly understood and agreed that no promises, provisions, terms, warranties, conditions, guarantees, or obligations whatsoever, either expressed or implied, other than as herein set forth or provided for shall be binding on either party.



Company:	Tri Dam Project
Contact Name:	Rich Ennis
Contact Phone:	(209) 559-4963
Contact Email:	rennis@tridamproject.com

Bill To:	31885 Old Strawberry Road Strawberry, CA 95375
----------	---

Ship To:	31885 Old Strawberry Road Strawberry, CA 95375
----------	---

Unit Type:	
Make:	Yale
Model:	GP050UX
Serial Number:	A7S1A06731W
Unit ID:	E25540 / 82838C
Power Source:	LPG
Mast:	3 Stage
Lift / Lowered Ht:	189 / 82
Fork Length:	48"
Fork Length:	Side Shift
Carriage:	
Attachment:	Solid Pneumatic
Tires:	2022
Tires:	Zero
Unit Year:	
Unit Hours:	
Charger:	
Carriage Width:	



Additional photos here

--

Preparation Level:	
--------------------	--

Description:	Brand New in stock unit
--------------	-------------------------

Prep Time:	two weeks
------------	-----------

Warranty:	1 year two thousand hours
-----------	---------------------------



Trade-In Value: \_\_\_\_\_

Unit Description: \_\_\_\_\_

Add-On Item : \_\_\_\_\_

Add-On Description: \_\_\_\_\_

Add-On Item : \_\_\_\_\_

Add-On Description: \_\_\_\_\_

## Payment Details

<u>Finance Terms</u>	<u>Term Detail</u>	<u>Term Length</u>	<u>Payment</u>	<u>Initial</u>
Option 1: _____	_____	_____	_____ + Tax & Fees	_____
Option 2: _____	_____	_____	_____ + Tax & Fees	_____
Option 3: _____	_____	_____	_____ + Tax & Fees	_____

Price Per Unit: 35,025.32 + Tax & Fees      Quantity: 1.00

Notes/Comments:

Total Investment: \$ 35,025.32 (Tax & Fees Not Included)



Will Langley  
Industrial Equipment Sales  
Next Level Warehouse Solutions  
2410 Grand Avenue  
Sacramento, CA 95838

Customer Name: Rich Ennis

Customer Signature: \_\_\_\_\_

PMH Account #: \_\_\_\_\_ PO #: \_\_\_\_\_

Territory Manager:

## Terms & Conditions

- Price excludes tax and fees, quote valid 30 days from 04/11/2023
- F.O.B. on delivery, For Terms and Conditions see [www.papemh.com/terms](http://www.papemh.com/terms)
- Credit card payment will not be accepted for this sale.
- 20% restocking fee will be assessed on cancelled orders.

# BOARD AGENDA REPORT

Date: 4/20/2023  
Staff: Chris Tuggle

---

**SUBJECT: F450 Replacement**

---

**RECOMMENDED ACTION: Approve purchasing 2023 International truck to replace the F450.**

---

**BACKGROUND AND/OR HISTORY:**

The F450 multi-use vehicle currently owned and operated by Tri-Dam is a 2008 and does not meet CARB standards for emissions. The Equipment Mechanic must apply annually for a 'Low Mileage Exemption' for Tri Dam to continue to own and operate. This limits the annual usage to 1000 miles. The replacement vehicle is a 4x4 International medium duty truck with a dump bed and plow assembly installed. It remains a Class C vehicle so all Tri-Dam employees can operate it when needed.

**FISCAL IMPACT:** Budget \$120,000

<b>ATTACHMENTS:</b>	International Truck Stockton Quote	\$119,290.31
	International Truck Turlock Quote	\$120,363.25
	Commercial Truck Quote	\$123,055.43

---

**Board Motion:**

**Motion by:** \_\_\_\_\_ **Second by:** \_\_\_\_\_

**VOTE:**

**OID:** DeBoer (Yes/No) Doornenbal (Yes/No) Orvis (Yes/No) Santos (Yes/No) Tobias (Yes/No)

**SSJID:** Holbrook (Yes/No) Kamper (Yes/No) Roos (Yes/No) Spyksma (Yes/No) Weststeyn (Yes/No)

**Prepared For:**  
 TRI DAM PROJECT  
 ALEX FLUD  
 PO Box 1158  
 Pinecrest, CA 95364-0158  
 (209)965 - 3998  
 Reference ID: N/A

**Presented By:**  
 INTERSTATE TRUCK CENTER  
 Bill Dugo  
 2110 S Sinclair Ave  
 STOCKTON CA 95215 -  
 (209)944-5821

Thank you for the opportunity to provide you with the following quotation on a new International truck. I am sure the following detailed specification will meet your operational requirements, and I look forward to serving your business needs.

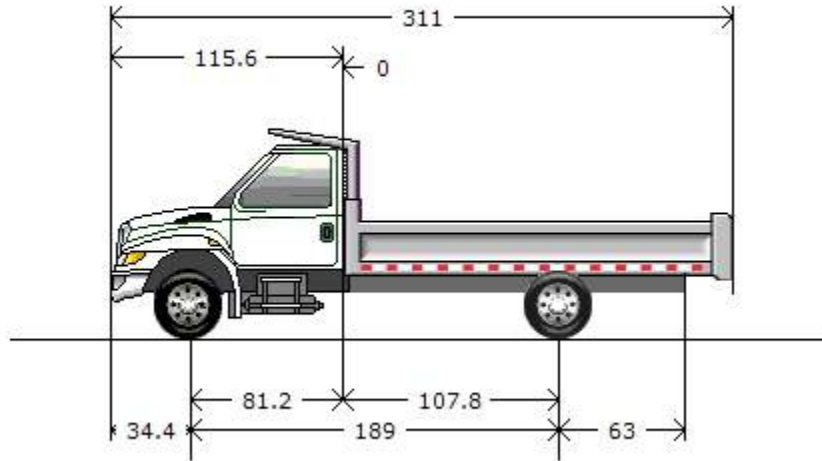

**Model Profile**  
**2023 CV515 SFA (CV515)**

<b>AXLE CONFIG:</b>	4X4
<b>APPLICATION:</b>	Landscape Dump
<b>MISSION:</b>	Requested GVWR: 23500. Calc. GVWR: 23000. Calc. GCWR: 37000 Calc. Start / Grade Ability: 34.24% / 2.21% @ 55 MPH Calc. Geared Speed: 103.2 MPH
<b>DIMENSION:</b>	Wheelbase: 189.00, CA: 107.80, Axle to Frame: 63.00
<b>ENGINE, DIESEL:</b>	{International 6.6} EPA 2021, 350HP @ 2700 RPM, 700 lb-ft Torque @ 1600 RPM, 2900 RPM Governed Speed, 350 Peak HP (Max)
<b>TRANSMISSION, AUTOMATIC:</b>	{Allison 2750 RDS} 6th Generation Controls, Close Ratio, 6-Speed with Double Overdrive, with PTO Provision, Less Retarder, Includes Park Pawl, with 23,500-lb GVW and 37,500-lb GCW Max, On/Off Highway
<b>AXLE, FRONT DRIVING:</b>	{Dana Spicer 60-256} Single Reduction, 7,500-lb Capacity, with Hub Piloted Wheel Mounting
<b>AXLE, REAR, SINGLE:</b>	{Dana Spicer S16-130} Single Reduction, 15,500-lb Capacity, 190 Wheel Ends Gear Ratio: 4.30
<b>CAB:</b>	Conventional, Day Cab
<b>TIRE, FRONT:</b>	(2) 225/70R19.5 Load Range H HDR+ (CONTINENTAL), 643 rev/mile, 87 MPH, Drive
<b>TIRE, REAR:</b>	(4) 225/70R19.5 Load Range H HDR+ (CONTINENTAL), 643 rev/mile, 87 MPH, Drive
<b>SUSPENSION, REAR, SINGLE:</b>	15,500-lb Capacity, Vari-Rate Springs
<b>PAINT:</b>	Cab schematic 100CX Location 1: 9219, Winter White (Std) Chassis schematic N/A

<u>Code</u>	<u>Description</u>	<u>List</u> (US DOLLAR)
CV51500	Base Chassis, Model CV515 SFA with 189.00 Wheelbase, 107.80 CA, and 63.00 Axle to Frame.	\$51,683.00
1570	TOW HOOK, FRONT (2) Frame Mounted	\$84.00
1AMM	SKID PLATE Steel, Frame Mounted, Protects the Transfer Case from the Ground	\$300.00
1ANB	AXLE CONFIGURATION {Navistar} 4x4	\$0.00
	<u>Notes</u> : Pricing may change if axle configuration is changed.	
1CGH	FRAME RAILS High Strength Low Alloy Steel (50,000 PSI Yield), Straight Top Flange with Contoured Bottom, Height Transitions from 7.375" (187.325mm) to 9.125" (231.775mm) to 7.625" (193.675mm); Width: 3.079" (78.21mm); Thickness: 0.3125" (7.94mm); 383.3" (9735.8mm) Max OAL	\$0.00
1LEG	LICENSE PLATE HOLDER Includes Upper & Lower Mounting Plate Hardware, Mounted in Existing Holes in Front Bumper	\$29.00
1LRZ	BUMPER, FRONT Contoured, Steel, Painted Black	\$0.00
1WEC	WHEELBASE RANGE 185" (470cm) Through and Including 236" (600cm)	\$579.00
1WND	AF RANGE 50" (128cm) Through and Including 75" (190cm)	\$100.00
2EWA	AXLE, FRONT DRIVING {Dana Spicer 60-256} Single Reduction, 7,500-lb Capacity, with Hub Piloted Wheel Mounting	\$1,400.00
2WLC	AXLE, FRONT DRIVING, LUBE {EmGard FE-75W-90} Synthetic Oil; 1 thru 29.99 Pints	\$147.00
3AJN	SUSPENSION, FRONT, SPRING Parabolic Taper Leaf, Shackle Type, 7,500-lb Capacity, with Shock Absorbers	\$9.00
3WAP	STABILIZER BAR, FRONT	\$360.00
4240	BRAKE SYSTEM, HYDRAULIC {Bosch} Split System, with Four Channel ABS, Traction Control, Electronic Stability Control, Hydromax Brake Booster with High Speed Master Cylinder and Trailer Sway Control	\$0.00
4EVD	DUST SHIELDS, FRONT BRAKE for Hydraulic Brakes	\$0.00
4EVE	DUST SHIELDS, REAR BRAKE for Hydraulic Brakes	\$0.00
4GBJ	BRAKE, PARKING {Bosch} DSSA Type, 12" x 3"; for Hydraulic Brake Chassis; Foot Operated in Cab; Differential Mounted	\$0.00
4XCU	BRAKES, FRONT {Meritor Quadraulic} Hydraulic Disc Type, with Four 64mm Diameter Pistons, 8,000-lb Capacity	\$0.00
4XCV	BRAKES, REAR {Meritor Quadraulic} Hydraulic Disc Type, with Four 64mm Diameter Pistons, 15,500-lb Capacity per Axle	\$0.00
5708	STEERING COLUMN Tilting	\$0.00
5CBG	STEERING WHEEL 4-Spoke; 15" Dia., Black	\$0.00
5PSS	STEERING GEAR {Bosch S2 8014 Plus} Power	\$0.00
6DHD	DRIVELINE SYSTEM {Dana Spicer} SPL100 Main Driveline, Direct Mount Transfer Case to Transmission, SPL70 Driveline to Front Axle, for 4x4	\$0.00
7BLL	EXHAUST SYSTEM Horizontal, Frame Mounted Right Side, Under Rail, for Single Exhaust	\$0.00
7SDS	ENGINE EXHAUST BRAKE for International 6.6 Engine	\$0.00

<u>Code</u>	<u>Description</u>	<u>List</u> (US DOLLAR)
7XAA	MANUAL REGEN Capability	\$0.00
8002	ELECTRICAL SYSTEM 12-Volt for CV Model	\$0.00
	<u>Includes</u> : HAZARD SWITCH Push On/Push Off, Located on Top of Steering Column Cover : HEADLIGHT DIMMER SWITCH Integral with Turn Signal Lever : PARKING LIGHT PARKING LIGHT Integral with Front Turn Signal and Rear Tail Light : TURN SIGNALS, FRONT Includes Reflectors and Solid State Flashers; Flush Mounted : WINDSHIELD WIPER SWITCH 2-Speed with Wash and Intermittent Feature, Integral with Turn Signal Lever	
8GJC	ALTERNATOR {Denso SC2/SC6} Dual, Brush Type, 12 Volt, 150 and 220 Amp Capacity	\$380.00
8HBW	TRAILER BRAKE CONTROL Integrated	\$275.00
8HXV	BODY BUILDER WIRING Back of Day Cab at Left Frame or Under Crew Cab at Left Frame; Includes One Sealed Connector for Separate Ground/Backup/Left and Right Hand Turn, Left and Right Hand Tail/Stop/Accessory Power and Combined for Left and Right Hand Stop/ Turn	\$100.00
8MWA	BATTERY SYSTEM {VARTA} Maintenance-Free, (2) 12-Volt 1300CCA Total, Top Threaded Stud	\$0.00
8RNM	RADIO AM/FM/Clock/Bluetooth, Seek/Scan, with 7" Color Touch Panel Display	\$353.00
8RNU	SPEAKERS (6)	\$37.00
8RNY	CAMERA SYSTEM, REAR VIEW Includes Camera, Mounting, Wiring and Interface to the Monitor, for the Back-up Camera System	\$415.00
8THB	BACK-UP ALARM Electric, 102 dBA	\$120.00
8TRA	TRAILER CONNECTION SOCKET Mounted at Rear of Frame, Wired for Turn Signals Combined with Stop, Compatible with Trailers with Combined Stop, Tail, Turn Lamps	\$94.00
8TUL	STOP, TURN, TAIL & B/U LIGHTS Multi-Function, Sealed, Incandescent Stop, Turn and Tail Lights, Backup Lights with Rear Reflex Reflector, Includes License Plate Light	\$0.00
8TUM	AUXILIARY HARNESS "Y" Harness for Auxiliary Front Head Lights (High/Low Beam), Marker Lights, and Turn Signals for Front Plow Applications	\$160.00
8TVV	SPECIAL WIRING HARNESS, BODY to Connect to Instrument Panel Electrical Center (ICEM) Connector X7, Provides Blunt Cuts for Standard Terminals 8, 11, 7, 17, 10, 19 Signals, Optional Terminals 1, 4, 14, 20 Signals	\$60.00
8VAY	HORN, ELECTRIC Disc Style	\$0.00
8VVB	BATTERY BOX Steel, with Plastic Cover, 2 Battery Capacity, Parallel to Rail, 28" Wide, Mounted Left Side Under Cab	\$0.00
8XJN	HEADLIGHTS Halogen, Composite Aero Design, Black Trim Bezel, with Daytime Running Lights	\$0.00
8XJP	SWITCH, AUXILIARY 1 to 4 Latching Switches with 30-Amp Fuses	\$0.00
8XJV	CLEARANCE/MARKER LIGHTS (5) Amber LED Lights, Flush Mounted on Cab	\$0.00
8XJW	STARTING MOTOR 12 Volt	\$0.00
9AAB	LOGOS EXTERIOR Model Badges	\$0.00
9HBZ	GRILLE Molded in Dark Gray	\$0.00
9WAC	BUG SCREEN Mounted Behind Grille	\$0.00

<u>Code</u>	<u>Description</u>	<u>List</u> (US DOLLAR)
9WAY	FRONT END Tilting, Fiberglass, with Three Piece Construction	\$0.00
9WBN	FENDER EXTENSIONS Painted	\$0.00
10060	PAINT SCHEMATIC, PT-1 Single Color, Design 100	\$0.00
10761	PAINT TYPE Base Coat/Clear Coat, 1-2 Tone	\$0.00
10SLV	PROMOTIONAL PACKAGE Government Silver Package	\$0.00
10WLR	GCWR RANGE GCWR Equal to or Less than 34,000-lb	\$0.00
10WUE	MUD FLAPS, FRONT WHEELS (2) Rubber, Mounted on Fender Extension	\$76.00
10XAX	GVWR WEIGHT CLASSIFICATION Class 6 (19,501-26,000 lbs)	\$2,394.00
12GAG	ENGINE, DIESEL {International 6.6} EPA 2021, 350HP @ 2700 RPM, 700 lb-ft Torque @ 1600 RPM, 2900 RPM Governed Speed, 350 Peak HP (Max)	\$0.00
	<u>Includes</u>	
	: GLOW PLUG Automatic with Indicator Light	
	: OIL FILTER, ENGINE Spin-On Type	
12TTM	FAN DRIVE Viscous Type, Screw On, Rear Tether, Electronically Controlled	\$0.00
12VGC	AIR CLEANER Single Element, with Water Separator	\$0.00
12VJP	EMISSION, CALENDAR YEAR {International 6.6} EPA, OBD and GHG Certified for Calendar Year 2023	\$0.00
12WGG	THROTTLE, HAND CONTROL Engine Speed Control for PTO; Electronic Controlled, On/Off Switch Mounted on Dash, with Steering Wheel Button Control	\$250.00
12WUT	GOVERNOR Electronic Road Speed Type; with 70 MPH Default	\$0.00
12WZJ	CARB IDLE COMPLIANCE Low NOx Idle Engine, Complies with California Clean Air Regulations; Includes "Certified Clean Idle" Decal located on Driver Door	\$97.00
12XBL	BLOCK HEATER, ENGINE 120V/800W	\$100.00
12XCU	CARB EMISSION WARR COMPLIANCE for International 6.6 Engines	\$0.00
12XZD	RADIATOR Aluminum, 3-Row, Down Flow, Front to Back System, 730 SqIn Louvered, with 578 SqIn Charge Air Cooler, Includes In-Tank Oil Cooler	\$0.00
13BCH	TRANSMISSION, AUTOMATIC {Allison 2750 RDS} 6th Generation Controls, Close Ratio, 6-Speed with Double Overdrive, with PTO Provision, Less Retarder, Includes Park Pawl, with 23,500-lb GVW and 37,500-lb GCW Max, On/Off Highway	\$2,455.00
13TLP	TRANSFER CASE {Meritor MTC-3203} 2-Speed, Gear Drive, 3,000 lb-ft Torque Rating, Less PTO Provision, Electric Shift Control	\$1,298.00
	<u>Notes</u>	
	: Transfer Case Includes 40W Synthetic Lube	
13TLS	PTO ACCOMMODATION PKG Includes Flex Section on Transmission Oil Cooler Lines to Enable PTO Lube Plumbing	\$30.00
13WVV	NEUTRAL AT STOP Allison Transmission Shifts to Neutral When Service Brake is Depressed and Vehicle is at Stop; Remains in Neutral Until Service Brake is Released	\$0.00
13WYY	SHIFT CONTROL PARAMETERS {Allison} 1000 or 2000 Series Transmissions, Performance Programming	\$0.00
13XAL	PTO LOCATION Customer Intends to Install PTO at Left Side of Transmission	\$0.00

<u>Code</u>	<u>Description</u>	<u>List</u> (US DOLLAR)
14897	DIFFERENTIAL, LOCKING {Dana Spicer Trac-Lok} Torque Proportioning Limited Slip	\$1,124.00
14AJE	AXLE, REAR, SINGLE {Dana Spicer S16-130} Single Reduction, 15,500-lb Capacity, 190 Wheel Ends . Gear Ratio: 4.30	\$207.00
14SAE	SUSPENSION, REAR, SINGLE 15,500-lb Capacity, Vari-Rate Springs	\$16.00
14WAP	SHOCK ABSORBERS, REAR (2)	\$171.00
14WMN	AXLE, REAR, LUBE {EmGard FE-75W-90} Synthetic Oil; 1 thru 29.99 Pints	\$92.00
15SZP	FUEL TANK Top Draw, Plastic, Rectangular, 17" Tank Depth, 25 US Gal (95L), Includes Auxiliary Draw Port and Fuel Filler Assembly, Mounted Between Frame Rails and Forward of Rear Axle	\$0.00
15WDZ	DEF TANK 6.75 US Gal (26L) Capacity, Frame Mounted Outside Right Rail, Under Cab	\$0.00
16030	CAB Conventional, Day Cab	\$0.00
	<u>Includes</u>	
	: CAB DOOR LOCKS Power Door Locks All Doors	
	: DOME LIGHT, CAB with OFF/DOOR/ON Settings; Located in Overhead Console	
	: READING LIGHT, CAB Located in Overhead Console	
	: STEP (2) One Per Door	
	: STORAGE POCKET, DOOR (2) Full Length, Driver and Passenger Door	
16ACA	MIRROR, INSIDE REAR VIEW Omit	\$0.00
16BBA	GLASS, ALL WINDOWS Solar Absorbing, Tint	\$0.00
16CEM	COLOR, INTERIOR Dark Ash	\$0.00
16HCT	GAUGE CLUSTER English Speedometer, Includes English Odometer; Includes 3.5" Monochromatic Display with Personalization, Warning Messages and Vehicle Information	\$0.00
16KVR	SEAT, DRIVER High Back with Integral Headrest, with Recline, Cloth, Manual Adjust Lumbar	\$22.00
16LVP	SEAT, TWO-MAN PASSENGER High Back with Integral Headrest in Outboard Position, Center Fold-Down Armrest with Storage, Cloth, with Recline	\$100.00
16STB	MIRRORS (2) Manual Folding, Power Adjust, Heated, Black Heads and Arms, for 102" Load Width	\$389.00
16VKB	CAB INTERIOR TRIM Classic, for Day Cab	\$0.00
	<u>Includes</u>	
	: SUN VISOR (2) Vinyl	
16WAK	WINDOW, POWER (2) in Left and Right Doors	\$247.00
16XCP	AIR BAG, FRONT, DRIVER SIDE	\$0.00
16XCR	AIR BAG, FRONT, PASSENGER SIDE	\$0.00
16XDE	AIR BAG, SIDE, DRIVER Seat Mounted, Outboard Side-Impact Airbag	\$0.00
16XDG	AIR BAG, SIDE, PASSENGER Seat Mounted, Outboard Side-Impact Airbag	\$0.00
16XDH	AIR BAG, SIDE CURTAIN Roof Mounted, for Front and Rear Outboard Seating Positions for Driver and Passenger Sides	\$0.00
16XZA	AIR CONDITIONER with Heater, Single Zone	\$0.00
27DTX	WHEELS, FRONT {Accuride 50180} DISC; 19.5x6.75 Rims, Powder Coat Steel, 4-Hand Hole, 8-Stud, 275mm BC, Hub-Piloted, Flanged Nut, with Steel Hubs	\$0.00

<u>Code</u>	<u>Description</u>	<u>List</u> (US DOLLAR)
28DTX	WHEELS, REAR {Accuride 50180} DUAL DISC; 19.5x6.75 Rims, Powder Coat Steel, 4-Hand Hole, 8-Stud, 275mm BC, Hub-Piloted, Flanged Nut, with Steel Hubs	\$0.00
7789445450	(2) TIRE, FRONT 225/70R19.5 Load Range H HDR+ (CONTINENTAL), 643 rev/mile, 87 MPH, Drive	\$170.00
7789445450	(4) TIRE, REAR 225/70R19.5 Load Range H HDR+ (CONTINENTAL), 643 rev/mile, 87 MPH, Drive	\$340.00
<b>Total of Product Features</b>		<b>\$66,263.00</b>
Cab schematic 100CX		
Location 1: 9219, Winter White (Std)		
Chassis schematic N/A		
<b>Services Section:</b>		
40131	WARRANTY Standard for CV515, Effective with Vehicles Built December 3, 2018 or Later, CTS-3000A	\$0.00
<b>Total of Service Features</b>		<b>\$0.00</b>
<b>Total List Price Including Options:</b>		<b>\$66,263.00</b> (US DOLLAR)
1	FUURNISH AND INSTALL 14'4" RUGBY CONTRACTOR DUMP BODY WITH RUGBY SF-28 ELECTRIC DOUBLE ACTING UNDERBODY SUBFRAME HOIST, 1/2" BUCK PLATE 15 TON COMBINATION PINTEL HITCH 2 5/16 BALL & 2-5/8 "D" RINGS, 36"X18"X18" STEEL TOOL BOX MOUNTED TO FRAME	\$24,386.00
2	FURNISH AND INSTALL MEYERS 9' ROAD PRO PLOW MODEL RP-32-9, PARK AND TURN SIGNAL CONTROL HARNESS	\$10,937.60
3	OPTIONAL ITEMS THAT TRI DAM MIGHT CONSIDER: SALT DOGG SPREADER INSTALLED \$9585.54	\$0.00
	MANUAL PULL TRARPING SYSTEM \$1749.00	
	EMERGENCY LIGHT \$2460.00	
<b>Total Body Allied:</b>		<b>\$35,323.60</b> (US DOLLAR)



<u>Description</u>	<u>(US DOLLAR)</u>	<u>Price</u>
Factory List Prices:		
Product Items	\$66,263.00	
Service Items	\$0.00	
Total Factory List Price Including Options:		\$66,263.00
Freight	\$1,950.00	
MY TIRE SURCHARGE @\$30.00 PER TIRE	\$180.00	
MY COMMODITY SURCHARGE	\$3,500.00	
Total Freight:		\$5,630.00
Total Factory List Price Including Freight:		\$71,893.00
Less Customer Allowance:		\$4,000.00
Total Vehicle Price:		\$75,893.00
Total Body/Allied Equipment:		\$35,323.60
Total Sale Price:		\$111,216.60
Total Per Vehicle Sales Price:		\$111,216.60
Total Net Sales Excluding Taxes:		\$111,216.60
CALIFORNIA TIRE TAX	\$10.50	
EXEMPT LICENSE PLATE N/C	\$0.00	
COUNTY SALES TAX @ 7.25%	\$8,063.21	
Total License, Title, & Taxes:		\$8,073.71
Net Sales Price:		\$119,290.31

Please feel free to contact me regarding these specifications should your interests or needs change. I am confident you will be pleased with the quality and service of an International vehicle.

**Approved by Seller:**

**Accepted by Purchaser:**

\_\_\_\_\_  
**Official Title and Date**

\_\_\_\_\_  
**Firm or Business Name**

\_\_\_\_\_  
**Authorized Signature**

\_\_\_\_\_  
**Authorized Signature and Date**

**This proposal is not binding upon the seller without Seller's Authorized Signature**

\_\_\_\_\_  
**Official Title and Date**

**The TOPS FET calculation is an estimate for reference purposes only. The seller or retailer is responsible for calculating and reporting/paying appropriate FET to the IRS.**

**The limited warranties applicable to the vehicles described herein are Navistar, Inc.'s standard printed warranties which are incorporated herein by reference and to which you have been provided a copy and hereby agree to their terms and conditions.**

**Prepared For:**  
 TRI DAM PROJECT  
 ALEX FLUD  
 PO Box 1158  
 Pinecrest, CA 95364-0158  
 (209)965 - 3998  
 Reference ID: N/A

**Presented By:**  
 INTERSTATE TRUCK CENTER  
 Todd Morganson  
 5843 N GOLDENSTATE BLVD  
 TURLOCK CA 95382 -  
 (209)669-5444

Thank you for the opportunity to provide you with the following quotation on a new International truck. I am sure the following detailed specification will meet your operational requirements, and I look forward to serving your business needs.

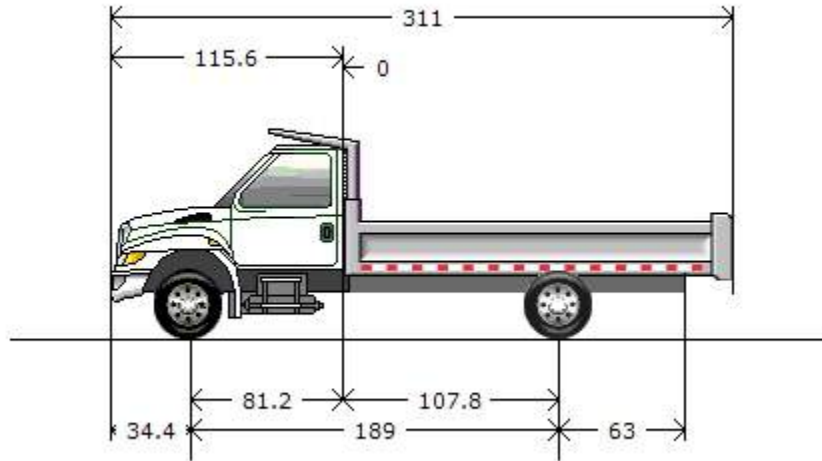

**Model Profile**  
**2023 CV515 SFA (CV515)**

<b>AXLE CONFIG:</b>	4X4
<b>APPLICATION:</b>	Landscape Dump
<b>MISSION:</b>	Requested GVWR: 23500. Calc. GVWR: 23000. Calc. GCWR: 37000 Calc. Start / Grade Ability: 34.24% / 2.21% @ 55 MPH Calc. Geared Speed: 103.2 MPH
<b>DIMENSION:</b>	Wheelbase: 189.00, CA: 107.80, Axle to Frame: 63.00
<b>ENGINE, DIESEL:</b>	{International 6.6} EPA 2021, 350HP @ 2700 RPM, 700 lb-ft Torque @ 1600 RPM, 2900 RPM Governed Speed, 350 Peak HP (Max)
<b>TRANSMISSION, AUTOMATIC:</b>	{Allison 2750 RDS} 6th Generation Controls, Close Ratio, 6-Speed with Double Overdrive, with PTO Provision, Less Retarder, Includes Park Pawl, with 23,500-lb GVW and 37,500-lb GCW Max, On/Off Highway
<b>AXLE, FRONT DRIVING:</b>	{Dana Spicer 60-256} Single Reduction, 7,500-lb Capacity, with Hub Piloted Wheel Mounting
<b>AXLE, REAR, SINGLE:</b>	{Dana Spicer S16-130} Single Reduction, 15,500-lb Capacity, 190 Wheel Ends Gear Ratio: 4.30
<b>CAB:</b>	Conventional, Day Cab
<b>TIRE, FRONT:</b>	(2) 225/70R19.5 Load Range H HDR+ (CONTINENTAL), 643 rev/mile, 87 MPH, Drive
<b>TIRE, REAR:</b>	(4) 225/70R19.5 Load Range H HDR+ (CONTINENTAL), 643 rev/mile, 87 MPH, Drive
<b>SUSPENSION, REAR, SINGLE:</b>	15,500-lb Capacity, Vari-Rate Springs
<b>PAINT:</b>	Cab schematic 100CX Location 1: 9219, Winter White (Std) Chassis schematic N/A

Electronic Parameters Data is Not Available.

<u>Code</u>	<u>Description</u>	<u>F/R Wt</u> (lbs)	<u>Tot Wt</u> (lbs)	<u>List</u> (US DOLLAR)
CV51500	Base Chassis, Model CV515 SFA with 189.00 Wheelbase, 107.80 CA, and 63.00 Axle to Frame.	4671/2886	7557	\$51,683.00
1570	TOW HOOK, FRONT (2) Frame Mounted	13/-1	12	\$84.00
1AMM	SKID PLATE Steel, Frame Mounted, Protects the Transfer Case from the Ground	49/15	64	\$300.00
1ANB	AXLE CONFIGURATION {Navistar} 4x4	0/0	0	\$0.00
	<u>Notes</u> : Pricing may change if axle configuration is changed.			
1CGH	FRAME RAILS High Strength Low Alloy Steel (50,000 PSI Yield), Straight Top Flange with Contoured Bottom, Height Transitions from 7.375" (187.325mm) to 9.125" (231.775mm) to 7.625" (193.675mm); Width: 3.079" (78.21mm); Thickness: 0.3125" (7.94mm); 383.3" (9735.8mm) Max OAL	61/101	162	\$0.00
1LEG	LICENSE PLATE HOLDER Includes Upper & Lower Mounting Plate Hardware, Mounted in Existing Holes in Front Bumper	2/0	2	\$29.00
1LRZ	BUMPER, FRONT Contoured, Steel, Painted Black	0/0	0	\$0.00
1WEC	WHEELBASE RANGE 185" (470cm) Through and Including 236" (600cm)	10/30	40	\$579.00
1WND	AF RANGE 50" (128cm) Through and Including 75" (190cm)	0/0	0	\$100.00
2EWA	AXLE, FRONT DRIVING {Dana Spicer 60-256} Single Reduction, 7,500-lb Capacity, with Hub Piloted Wheel Mounting	155/0	155	\$1,400.00
2WLC	AXLE, FRONT DRIVING, LUBE {EmGard FE-75W-90} Synthetic Oil; 1 thru 29.99 Pints	0/0	0	\$147.00
3AJN	SUSPENSION, FRONT, SPRING Parabolic Taper Leaf, Shackle Type, 7,500-lb Capacity, with Shock Absorbers	31/0	31	\$9.00
3WAP	STABILIZER BAR, FRONT	50/0	50	\$360.00
4240	BRAKE SYSTEM, HYDRAULIC {Bosch} Split System, with Four Channel ABS, Traction Control, Electronic Stability Control, Hydromax Brake Booster with High Speed Master Cylinder and Trailer Sway Control	0/0	0	\$0.00
4EVD	DUST SHIELDS, FRONT BRAKE for Hydraulic Brakes	0/0	0	\$0.00
4EVE	DUST SHIELDS, REAR BRAKE for Hydraulic Brakes	0/0	0	\$0.00
4GBJ	BRAKE, PARKING {Bosch} DSSA Type, 12" x 3"; for Hydraulic Brake Chassis; Foot Operated in Cab; Differential Mounted	0/0	0	\$0.00
4XCU	BRAKES, FRONT {Meritor Quadraulic} Hydraulic Disc Type, with Four 64mm Diameter Pistons, 8,000-lb Capacity	0/0	0	\$0.00
4XCV	BRAKES, REAR {Meritor Quadraulic} Hydraulic Disc Type, with Four 64mm Diameter Pistons, 15,500-lb Capacity per Axle	0/0	0	\$0.00
5708	STEERING COLUMN Tilting	0/0	0	\$0.00
5CBG	STEERING WHEEL 4-Spoke; 15" Dia., Black	0/0	0	\$0.00
5PSS	STEERING GEAR {Bosch S2 8014 Plus} Power	0/0	0	\$0.00

<u>Code</u>	<u>Description</u>	<u>F/R Wt</u> (lbs)	<u>Tot Wt</u> (lbs)	<u>List</u> (US DOLLAR)
6DHD	DRIVELINE SYSTEM {Dana Spicer} SPL100 Main Driveline, Direct Mount Transfer Case to Transmission, SPL70 Driveline to Front Axle, for 4x4	0/2	2	\$0.00
7BLL	EXHAUST SYSTEM Horizontal, Frame Mounted Right Side, Under Rail, for Single Exhaust	0/0	0	\$0.00
7SDS	ENGINE EXHAUST BRAKE for International 6.6 Engine	0/0	0	\$0.00
7XAA	MANUAL REGEN Capability	0/0	0	\$0.00
8002	ELECTRICAL SYSTEM 12-Volt for CV Model	0/0	0	\$0.00
	<u>Includes</u> : HAZARD SWITCH Push On/Push Off, Located on Top of Steering Column Cover : HEADLIGHT DIMMER SWITCH Integral with Turn Signal Lever : PARKING LIGHT PARKING LIGHT Integral with Front Turn Signal and Rear Tail Light : TURN SIGNALS, FRONT Includes Reflectors and Solid State Flashers; Flush Mounted : WINDSHIELD WIPER SWITCH 2-Speed with Wash and Intermittent Feature, Integral with Turn Signal Lever			
8GJC	ALTERNATOR {Denso SC2/SC6} Dual, Brush Type, 12 Volt, 150 and 220 Amp Capacity	18/0	18	\$380.00
8HXV	BODY BUILDER WIRING Back of Day Cab at Left Frame or Under Crew Cab at Left Frame; Includes One Sealed Connector for Separate Ground/Backup/Left and Right Hand Turn, Left and Right Hand Tail/Stop/Accessory Power and Combined for Left and Right Hand Stop/Turn	3/1	4	\$100.00
8MWA	BATTERY SYSTEM {VARTA} Maintenance-Free, (2) 12-Volt 1300CCA Total, Top Threaded Stud	0/0	0	\$0.00
8RNM	RADIO AM/FM/Clock/Bluetooth, Seek/Scan, with 7" Color Touch Panel Display	1/0	1	\$353.00
8RNU	SPEAKERS (6)	2/0	2	\$37.00
8RNY	CAMERA SYSTEM, REAR VIEW Includes Camera, Mounting, Wiring and Interface to the Monitor, for the Back-up Camera System	0/2	2	\$415.00
8THB	BACK-UP ALARM Electric, 102 dBA	1/5	6	\$120.00
8TUL	STOP, TURN, TAIL & B/U LIGHTS Multi-Function, Sealed, Incandescent Stop, Turn and Tail Lights, Backup Lights with Rear Reflex Reflector, Includes License Plate Light	0/0	0	\$0.00
8TUM	AUXILIARY HARNESS "Y" Harness for Auxiliary Front Head Lights (High/Low Beam), Marker Lights, and Turn Signals for Front Plow Applications	1/0	1	\$160.00
8TVV	SPECIAL WIRING HARNESS, BODY to Connect to Instrument Panel Electrical Center (ICEM) Connector X7, Provides Blunt Cuts for Standard Terminals 8, 11, 7, 17, 10, 19 Signals, Optional Terminals 1, 4, 14, 20 Signals	0/0	0	\$60.00
8VAY	HORN, ELECTRIC Disc Style	0/0	0	\$0.00

<u>Code</u>	<u>Description</u>	<u>F/R Wt</u> (lbs)	<u>Tot Wt</u> (lbs)	<u>List</u> (US DOLLAR)
8VVB	BATTERY BOX Steel, with Plastic Cover, 2 Battery Capacity, Parallel to Rail, 28" Wide, Mounted Left Side Under Cab	0/0	0	\$0.00
8XJN	HEADLIGHTS Halogen, Composite Aero Design, Black Trim Bezel, with Daytime Running Lights	0/0	0	\$0.00
8XJP	SWITCH, AUXILIARY 1 to 4 Latching Switches with 30-Amp Fuses	0/0	0	\$0.00
8XJV	CLEARANCE/MARKER LIGHTS (5) Amber LED Lights, Flush Mounted on Cab	0/0	0	\$0.00
8XJW	STARTING MOTOR 12 Volt	0/0	0	\$0.00
9AAB	LOGOS EXTERIOR Model Badges	0/0	0	\$0.00
9HBZ	GRILLE Molded in Dark Gray	0/0	0	\$0.00
9WAC	BUG SCREEN Mounted Behind Grille	0/0	0	\$0.00
9WAY	FRONT END Tilting, Fiberglass, with Three Piece Construction	0/0	0	\$0.00
9WBN	FENDER EXTENSIONS Painted	0/0	0	\$0.00
10060	PAINT SCHEMATIC, PT-1 Single Color, Design 100	0/0	0	\$0.00
10761	PAINT TYPE Base Coat/Clear Coat, 1-2 Tone	0/0	0	\$0.00
10SLV	PROMOTIONAL PACKAGE Government Silver Package	0/0	0	\$0.00
10WLR	GCWR RANGE GCWR Equal to or Less than 34,000-lb	0/0	0	\$0.00
10WUE	MUD FLAPS, FRONT WHEELS (2) Rubber, Mounted on Fender Extension	12/0	12	\$76.00
10XAX	GVWR WEIGHT CLASSIFICATION Class 6 (19,501-26,000 lbs)	0/0	0	\$2,394.00
12GAG	ENGINE, DIESEL {International 6.6} EPA 2021, 350HP @ 2700 RPM, 700 lb-ft Torque @ 1600 RPM, 2900 RPM Governed Speed, 350 Peak HP (Max)  <u>Includes</u> : GLOW PLUG Automatic with Indicator Light : OIL FILTER, ENGINE Spin-On Type	0/0	0	\$0.00
12TTM	FAN DRIVE Viscous Type, Screw On, Rear Tether, Electronically Controlled	0/0	0	\$0.00
12VGC	AIR CLEANER Single Element, with Water Separator	0/0	0	\$0.00
12VJP	EMISSION, CALENDAR YEAR {International 6.6} EPA, OBD and GHG Certified for Calendar Year 2023	0/0	0	\$0.00
12WGG	THROTTLE, HAND CONTROL Engine Speed Control for PTO; Electronic Controlled, On/Off Switch Mounted on Dash, with Steering Wheel Button Control	0/0	0	\$250.00
12WUT	GOVERNOR Electronic Road Speed Type; with 70 MPH Default	0/0	0	\$0.00
12WZJ	CARB IDLE COMPLIANCE Low NOx Idle Engine, Complies with California Clean Air Regulations; Includes "Certified Clean Idle" Decal located on Driver Door	0/0	0	\$97.00
12XBL	BLOCK HEATER, ENGINE 120V/800W	0/0	0	\$100.00

<u>Code</u>	<u>Description</u>	<u>F/R Wt</u> (lbs)	<u>Tot Wt</u> (lbs)	<u>List</u> (US DOLLAR)
12XCU	CARB EMISSION WARR COMPLIANCE for International 6.6 Engines	0/0	0	\$0.00
12XZD	RADIATOR Aluminum, 3-Row, Down Flow, Front to Back System, 730 SqIn Louvered, with 578 SqIn Charge Air Cooler, Includes In-Tank Oil Cooler	0/0	0	\$0.00
13BCH	TRANSMISSION, AUTOMATIC {Allison 2750 RDS} 6th Generation Controls, Close Ratio, 6-Speed with Double Overdrive, with PTO Provision, Less Retarder, Includes Park Pawl, with 23,500-lb GVW and 37,500-lb GCW Max, On/Off Highway	0/0	0	\$2,455.00
13TLP	TRANSFER CASE {Meritor MTC-3203} 2-Speed, Gear Drive, 3,000 lb-ft Torque Rating, Less PTO Provision, Electric Shift Control	158/30	188	\$1,298.00
	<u>Notes</u> : Transfer Case Includes 40W Synthetic Lube			
13TLS	PTO ACCOMMODATION PKG Includes Flex Section on Transmission Oil Cooler Lines to Enable PTO Lube Plumbing	0/0	0	\$30.00
13WVV	NEUTRAL AT STOP Allison Transmission Shifts to Neutral When Service Brake is Depressed and Vehicle is at Stop; Remains in Neutral Until Service Brake is Released	0/0	0	\$0.00
13WYY	SHIFT CONTROL PARAMETERS {Allison} 1000 or 2000 Series Transmissions, Performance Programming	0/0	0	\$0.00
13XAL	PTO LOCATION Customer Intends to Install PTO at Left Side of Transmission	0/0	0	\$0.00
14897	DIFFERENTIAL, LOCKING {Dana Spicer Trac-Lok} Torque Proportioning Limited Slip	0/0	0	\$1,124.00
14AJE	AXLE, REAR, SINGLE {Dana Spicer S16-130} Single Reduction, 15,500-lb Capacity, 190 Wheel Ends . Gear Ratio: 4.30	0/12	12	\$207.00
14SAE	SUSPENSION, REAR, SINGLE 15,500-lb Capacity, Vari-Rate Springs	0/41	41	\$16.00
14WAP	SHOCK ABSORBERS, REAR (2)	0/50	50	\$171.00
14WMN	AXLE, REAR, LUBE {EmGard FE-75W-90} Synthetic Oil; 1 thru 29.99 Pints	0/0	0	\$92.00
15SZP	FUEL TANK Top Draw, Plastic, Rectangular, 17" Tank Depth, 25 US Gal (95L), Includes Auxiliary Draw Port and Fuel Filler Assembly, Mounted Between Frame Rails and Forward of Rear Axle	28/-65	-37	\$0.00
15WDZ	DEF TANK 6.75 US Gal (26L) Capacity, Frame Mounted Outside Right Rail, Under Cab	0/0	0	\$0.00
16030	CAB Conventional, Day Cab	0/0	0	\$0.00
	<u>Includes</u> : CAB DOOR LOCKS Power Door Locks All Doors : DOME LIGHT, CAB with OFF/DOOR/ON Settings; Located in Overhead Console : READING LIGHT, CAB Located in Overhead Console			

<u>Code</u>	<u>Description</u>	<u>F/R Wt</u> (lbs)	<u>Tot Wt</u> (lbs)	<u>List</u> (US DOLLAR)
	: STEP (2) One Per Door : STORAGE POCKET, DOOR (2) Full Length, Driver and Passenger Door			
16ACA	MIRROR, INSIDE REAR VIEW Omit	0/0	0	\$0.00
16BBA	GLASS, ALL WINDOWS Solar Absorbing, Tint	0/0	0	\$0.00
16CEM	COLOR, INTERIOR Dark Ash	0/0	0	\$0.00
16HCT	GAUGE CLUSTER English Speedometer, Includes English Odometer; Includes 3.5" Monochromatic Display with Personalization, Warning Messages and Vehicle Information	0/0	0	\$0.00
16KVR	SEAT, DRIVER High Back with Integral Headrest, with Recline, Cloth, Manual Adjust Lumbar	0/0	0	\$22.00
16LVP	SEAT, TWO-MAN PASSENGER High Back with Integral Headrest in Outboard Position, Center Fold-Down Armrest with Storage, Cloth, with Recline	0/0	0	\$100.00
16STB	MIRRORS (2) Manual Folding, Power Adjust, Heated, Black Heads and Arms, for 102" Load Width	19/3	22	\$389.00
16VKB	CAB INTERIOR TRIM Classic, for Day Cab  <u>Includes</u> : SUN VISOR (2) Vinyl	0/0	0	\$0.00
16WAK	WINDOW, POWER (2) in Left and Right Doors	0/0	0	\$247.00
16XCP	AIR BAG, FRONT, DRIVER SIDE	0/0	0	\$0.00
16XCR	AIR BAG, FRONT, PASSENGER SIDE	0/0	0	\$0.00
16XDE	AIR BAG, SIDE, DRIVER Seat Mounted, Outboard Side-Impact Airbag	0/0	0	\$0.00
16XDG	AIR BAG, SIDE, PASSENGER Seat Mounted, Outboard Side-Impact Airbag	0/0	0	\$0.00
16XDH	AIR BAG, SIDE CURTAIN Roof Mounted, for Front and Rear Outboard Seating Positions for Driver and Passenger Sides	0/0	0	\$0.00
16XZA	AIR CONDITIONER with Heater, Single Zone	0/0	0	\$0.00
27DTX	WHEELS, FRONT {Accuride 50180} DISC; 19.5x6.75 Rims, Powder Coat Steel, 4-Hand Hole, 8-Stud, 275mm BC, Hub-Piloted, Flanged Nut, with Steel Hubs	0/0	0	\$0.00
28DTX	WHEELS, REAR {Accuride 50180} DUAL DISC; 19.5x6.75 Rims, Powder Coat Steel, 4-Hand Hole, 8-Stud, 275mm BC, Hub-Piloted, Flanged Nut, with Steel Hubs	0/0	0	\$0.00
7789445450	(2) TIRE, FRONT 225/70R19.5 Load Range H HDR+ (CONTINENTAL), 643 rev/mile, 87 MPH, Drive	6/0	6	\$170.00
7789445450	(4) TIRE, REAR 225/70R19.5 Load Range H HDR+ (CONTINENTAL), 643 rev/mile, 87 MPH, Drive	0/12	12	\$340.00
<b>Total of Product Features</b>				<b>\$65,894.00</b>

**Services Section:**



<b>Code</b>	<b>Description</b>	<b>F/R Wt</b> (lbs)	<b>Tot Wt</b> (lbs)	<b>List</b> (US DOLLAR)
40131	WARRANTY Standard for CV515, Effective with Vehicles Built December 3, 2018 or Later, CTS-3000A	0/0	0	\$0.00
<b>Total of Service Features</b>				<b>\$0.00</b>
<b>Total Component Weight:</b>		<b>5291/3124</b>	<b>8415</b>	
<b>Total List Price Including Options:</b>				<b>\$65,894.00</b>
		(lbs)	(lbs)	(US DOLLAR)
1	14.4 Rugby Contractor Body and Steel Toolbox Mounted	0/0	0	\$24,386.00
2	Install Meyers 9 Road Pro Plow Model RP-32-9 With lights	0/0	0	\$10,937.60
3	optional Tri Dam Salt Dogg Spreader \$9585.54	0/0	0	\$0.00
4	Manual Tarping System \$ 1749.00	0/0	0	\$0.00
5	Emergency Lighting System \$ 2460.00	0/0	0	\$0.00
<b>Total Body Allied:</b>		<b>0/0</b>	<b>0</b>	<b>\$35,323.60</b>
		(lbs)	(lbs)	(US DOLLAR)

The weight calculations included in this proposal are an estimate of future vehicle weight. The actual weight as manufactured may be different from the estimated weight. Navistar, Inc. shall not be liable for any consequences resulting from any differences between the estimated weight of a vehicle and the actual weight.

<u>Description</u>	<u>(US DOLLAR)</u>	<u>Price</u>
Factory List Prices:		
Product Items	\$65,894.00	
Service Items	\$0.00	
Total Factory List Price Including Options:		\$65,894.00
Freight	\$1,950.00	
Tire Surcharge	\$180.00	
Commodity Surcharge	\$3,500.00	
Total Freight:		\$5,630.00
Total Factory List Price Including Freight:		\$71,524.00
Less Customer Allowance:		\$5,750.00
Total Vehicle Price:		\$77,274.00
Total Body/Allied Equipment:		\$35,323.60
Total Sale Price:		\$112,597.60
Total Per Vehicle Sales Price:		\$112,597.60
Total Net Sales Excluding Taxes:		\$112,597.60
California Tire Tax	\$10.50	
California License Exempt	\$0.00	
Sales Tax County 7.25%	\$7,755.15	
Total License, Title, & Taxes:		\$7,765.65
Net Sales Price:		\$120,363.25

Please feel free to contact me regarding these specifications should your interests or needs change. I am confident you will be pleased with the quality and service of an International vehicle.

**Approved by Seller:**

**Accepted by Purchaser:**

\_\_\_\_\_  
Official Title and Date

\_\_\_\_\_  
Firm or Business Name

\_\_\_\_\_  
Authorized Signature

\_\_\_\_\_  
Authorized Signature and Date

**This proposal is not binding upon the seller without Seller's Authorized Signature**

\_\_\_\_\_  
Official Title and Date

**The TOPS FET calculation is an estimate for reference purposes only. The seller or retailer is responsible for calculating and reporting/paying appropriate FET to the IRS.**

**The limited warranties applicable to the vehicles described herein are Navistar, Inc.'s standard printed warranties which are incorporated herein by reference and to which you have been provided a copy and hereby agree to their terms and conditions.**

(US DOLLAR)

Description

Price

14.4 Rugby Contractor Body and Steel Toolbox Mounted	\$24,386.00
Install Meyers 9 Road Pro Plow Model RP-32-9 With lights	\$10,937.60
optional Tri Dam Salt Dogg Spreader \$9585.54	\$0.00
Manual Tarping System \$ 1749.00	\$0.00
Emergency Lighting System \$ 2460.00	\$0.00

Total Body Allied/Equipment: \$35,323.60

**Prepared For:**  
TRI DAM PROJECT  
Alex Flud  
PO Box 1158  
Pinecrest, CA 95364-0158  
(209)965 - 3998  
Reference ID: N/A

**Presented By:**  
COMMERCIAL TRUCK COMPANY  
Paul Arnaudo  
703 ABBOTT ST  
SALINAS CA 93901 -  
(831)424-2961

Thank you for the opportunity to provide you with the following quotation on a new International truck. I am sure the following detailed specification will meet your operational requirements, and I look forward to serving your business needs.

**Model Profile**  
**2024 CV515 SFA (CV515)**

<b>AXLE CONFIG:</b>	4X4
<b>APPLICATION:</b>	Landscape Dump
<b>MISSION:</b>	Requested GVWR: 19500. Calc. GVWR: 23000. Calc. GCWR: 37000 Calc. Geared Speed: 103.2 MPH
<b>DIMENSION:</b>	Wheelbase: 189.00, CA: 107.80, Axle to Frame: 63.00
<b>ENGINE, DIESEL:</b>	{International 6.6} EPA 2021, 350HP @ 2700 RPM, 700 lb-ft Torque @ 1600 RPM, 2900 RPM Governed Speed, 350 Peak HP (Max)
<b>TRANSMISSION, AUTOMATIC:</b>	{Allison 2750 RDS} 6th Generation Controls, Close Ratio, 6-Speed with Double Overdrive, with PTO Provision, Less Retarder, Includes Park Pawl, with 23,500-lb GVW and 37,500-lb GCW Max, On/Off Highway
<b>AXLE, FRONT DRIVING:</b>	{Dana Spicer 60-256} Single Reduction, 7,500-lb Capacity, with Hub Piloted Wheel Mounting
<b>AXLE, REAR, SINGLE:</b>	{Dana Spicer S16-130} Single Reduction, 15,500-lb Capacity, 190 Wheel Ends Gear Ratio: 4.30
<b>CAB:</b>	Conventional, Day Cab
<b>TIRE, FRONT:</b>	(2) 225/70R19.5 Load Range H HDR+ (CONTINENTAL), 643 rev/mile, 87 MPH, Drive
<b>TIRE, REAR:</b>	(4) 225/70R19.5 Load Range H HDR+ (CONTINENTAL), 643 rev/mile, 87 MPH, Drive
<b>SUSPENSION, REAR, SINGLE:</b>	15,500-lb Capacity, Vari-Rate Springs
<b>PAINT:</b>	Cab schematic 100CX Location 1: 9219, Winter White (Std) Chassis schematic N/A

**Description**

Base Chassis, Model CV515 SFA with 189.00 Wheelbase, 107.80 CA, and 63.00 Axle to Frame.

TOW HOOK, FRONT (2) Frame Mounted

SKID PLATE Steel, Frame Mounted, Protects the Transfer Case from the Ground

AXLE CONFIGURATION {Navistar} 4x4

**Notes**

: Pricing may change if axle configuration is changed.

FRAME RAILS High Strength Low Alloy Steel (50,000 PSI Yield), Straight Top Flange with Contoured Bottom, Height Transitions from 7.375" (187.325mm) to 9.125" (231.775mm) to 7.625" (193.675mm); Width: 3.079" (78.21mm); Thickness: 0.3125" (7.94mm); 383.3" (9735.8mm) Max OAL

LICENSE PLATE HOLDER Includes Upper & Lower Mounting Plate Hardware, Mounted in Existing Holes in Front Bumper

BUMPER, FRONT Contoured, Steel, Painted Black

WHEELBASE RANGE 185" (470cm) Through and Including 236" (600cm)

AF RANGE 50" (128cm) Through and Including 75" (190cm)

AXLE, FRONT DRIVING {Dana Spicer 60-256} Single Reduction, 7,500-lb Capacity, with Hub Piloted Wheel Mounting

AXLE, FRONT DRIVING, LUBE {EmGard FE-75W-90} Synthetic Oil; 1 thru 29.99 Pints

SUSPENSION, FRONT, SPRING Parabolic Taper Leaf, Shackle Type, 7,500-lb Capacity, with Shock Absorbers

STABILIZER BAR, FRONT

BRAKE SYSTEM, HYDRAULIC {Bosch} Split System, with Four Channel ABS, Traction Control, Electronic Stability Control, Hydromax Brake Booster with High Speed Master Cylinder and Trailer Sway Control

DUST SHIELDS, FRONT BRAKE for Hydraulic Brakes

DUST SHIELDS, REAR BRAKE for Hydraulic Brakes

BRAKE, PARKING {Bosch} DSSA Type, 12" x 3"; for Hydraulic Brake Chassis; Foot Operated in Cab; Differential Mounted

BRAKES, FRONT {Meritor Quadraulic} Hydraulic Disc Type, with Four 64mm Diameter Pistons, 8,000-lb Capacity

BRAKES, REAR {Meritor Quadraulic} Hydraulic Disc Type, with Four 64mm Diameter Pistons, 15,500-lb Capacity per Axle

STEERING COLUMN Tilting

STEERING WHEEL 4-Spoke; 15" Dia., Black

STEERING GEAR {Bosch S2 8014 Plus} Power

DRIVELINE SYSTEM {Dana Spicer} SPL100 Main Driveline, Direct Mount Transfer Case to Transmission, SPL70 Driveline to Front Axle, for 4x4

EXHAUST SYSTEM Horizontal, Frame Mounted Right Side, Under Rail, for Single Exhaust

ENGINE EXHAUST BRAKE for International 6.6 Engine

MANUAL REGEN Capability

ELECTRICAL SYSTEM 12-Volt for CV Model

**Includes**

: HAZARD SWITCH Push On/Push Off, Located on Top of Steering Column Cover

: HEADLIGHT DIMMER SWITCH Integral with Turn Signal Lever

: PARKING LIGHT PARKING LIGHT Integral with Front Turn Signal and Rear Tail Light

: TURN SIGNALS, FRONT Includes Reflectors and Solid State Flashers; Flush Mounted

: WINDSHIELD WIPER SWITCH 2-Speed with Wash and Intermittent Feature, Integral with Turn Signal Lever

**Description**

ALTERNATOR {Denso SC2/SC6} Dual, Brush Type, 12 Volt, 150 and 220 Amp Capacity

BODY BUILDER WIRING Back of Day Cab at Left Frame or Under Crew Cab at Left Frame; Includes One Sealed Connector for Separate Ground/Backup/Left and Right Hand Turn, Left and Right Hand Tail/Stop/Accessory Power and Combined for Left and Right Hand Stop/Turn

BATTERY SYSTEM {VARTA} Maintenance-Free, (2) 12-Volt 1300CCA Total, Top Threaded Stud

RADIO AM/FM/Clock/Bluetooth, Seek/Scan, with 7" Color Touch Panel Display

SPEAKERS (6)

CAMERA SYSTEM, REAR VIEW Includes Camera, Mounting, Wiring and Interface to the Monitor, for the Back-up Camera System

BACK-UP ALARM Electric, 102 dBA

STOP, TURN, TAIL & B/U LIGHTS Multi-Function, Sealed, Incandescent Stop, Turn and Tail Lights, Backup Lights with Rear Reflex Reflector, Includes License Plate Light

AUXILIARY HARNESS "Y" Harness for Auxiliary Front Head Lights (High/Low Beam), Marker Lights, and Turn Signals for Front Plow Applications

SPECIAL WIRING HARNESS, BODY to Connect to Instrument Panel Electrical Center (ICEM) Connector X7, Provides Blunt Cuts for Standard Terminals 8, 11, 7, 17, 10, 19 Signals, Optional Terminals 1, 4, 14, 20 Signals

HORN, ELECTRIC Disc Style

BATTERY BOX Steel, with Plastic Cover, 2 Battery Capacity, Parallel to Rail, 28" Wide, Mounted Left Side Under Cab

HEADLIGHTS Halogen, Composite Aero Design, Black Trim Bezel, with Daytime Running Lights

SWITCH, AUXILIARY 1 to 4 Latching Switches with 30-Amp Fuses

CLEARANCE/MARKER LIGHTS (5) Amber LED Lights, Flush Mounted on Cab

STARTING MOTOR 12 Volt

LOGOS EXTERIOR Model Badges

GRILLE Molded in Dark Gray

BUG SCREEN Mounted Behind Grille

FRONT END Tilting, Fiberglass, with Three Piece Construction

FENDER EXTENSIONS Painted

PAINT SCHEMATIC, PT-1 Single Color, Design 100

PAINT TYPE Base Coat/Clear Coat, 1-2 Tone

PROMOTIONAL PACKAGE Government Silver Package

GCWR RANGE GCWR Equal to or Less than 34,000-lb

MUD FLAPS, FRONT WHEELS (2) Rubber, Mounted on Fender Extension

GVWR WEIGHT CLASSIFICATION Class 6 (19,501-26,000 lbs)

ENGINE, DIESEL {International 6.6} EPA 2021, 350HP @ 2700 RPM, 700 lb-ft Torque @ 1600 RPM, 2900 RPM Governed Speed, 350 Peak HP (Max)

**Includes**

: GLOW PLUG Automatic with Indicator Light

: OIL FILTER, ENGINE Spin-On Type

FAN DRIVE Viscous Type, Screw On, Rear Tether, Electronically Controlled

**Description**

AIR CLEANER Single Element, with Water Separator

EMISSION, CALENDAR YEAR {International 6.6} EPA, OBD and GHG Certified for Calendar Year 2023

THROTTLE, HAND CONTROL Engine Speed Control for PTO; Electronic Controlled, On/Off Switch Mounted on Dash, with Steering Wheel Button Control

GOVERNOR Electronic Road Speed Type; with 70 MPH Default

CARB IDLE COMPLIANCE Low NOx Idle Engine, Complies with California Clean Air Regulations; Includes "Certified Clean Idle" Decal located on Driver Door

BLOCK HEATER, ENGINE 120V/800W

CARB EMISSION WARR COMPLIANCE for International 6.6 Engines

RADIATOR Aluminum, 3-Row, Down Flow, Front to Back System, 730 SqIn Louvered, with 578 SqIn Charge Air Cooler, Includes In-Tank Oil Cooler

TRANSMISSION, AUTOMATIC {Allison 2750 RDS} 6th Generation Controls, Close Ratio, 6-Speed with Double Overdrive, with PTO Provision, Less Retarder, Includes Park Pawl, with 23,500-lb GVW and 37,500-lb GCW Max, On/Off Highway

TRANSFER CASE {Meritor MTC-3203} 2-Speed, Gear Drive, 3,000 lb-ft Torque Rating, Less PTO Provision, Electric Shift Control

**Notes**

: Transfer Case Includes 40W Synthetic Lube

PTO ACCOMMODATION PKG Includes Flex Section on Transmission Oil Cooler Lines to Enable PTO Lube Plumbing

NEUTRAL AT STOP Allison Transmission Shifts to Neutral When Service Brake is Depressed and Vehicle is at Stop; Remains in Neutral Until Service Brake is Released

SHIFT CONTROL PARAMETERS {Allison} 1000 or 2000 Series Transmissions, Performance Programming

PTO LOCATION Customer Intends to Install PTO at Left Side of Transmission

DIFFERENTIAL, LOCKING {Dana Spicer Trac-Lok} Torque Proportioning Limited Slip

AXLE, REAR, SINGLE {Dana Spicer S16-130} Single Reduction, 15,500-lb Capacity, 190 Wheel Ends . Gear Ratio: 4.30

SUSPENSION, REAR, SINGLE 15,500-lb Capacity, Vari-Rate Springs

SHOCK ABSORBERS, REAR (2)

AXLE, REAR, LUBE {EmGard FE-75W-90} Synthetic Oil; 1 thru 29.99 Pints

FUEL TANK Top Draw, Plastic, Rectangular, 17" Tank Depth, 25 US Gal (95L), Includes Auxiliary Draw Port and Fuel Filler Assembly, Mounted Between Frame Rails and Forward of Rear Axle

DEF TANK 6.75 US Gal (26L) Capacity, Frame Mounted Outside Right Rail, Under Cab

CAB Conventional, Day Cab

**Includes**

: CAB DOOR LOCKS Power Door Locks All Doors

: DOME LIGHT, CAB with OFF/DOOR/ON Settings; Located in Overhead Console

: READING LIGHT, CAB Located in Overhead Console

: STEP (2) One Per Door

: STORAGE POCKET, DOOR (2) Full Length, Driver and Passenger Door

MIRROR, INSIDE REAR VIEW Omit

GLASS, ALL WINDOWS Solar Absorbing, Tint

COLOR, INTERIOR Dark Ash

**Description**

GAUGE CLUSTER English Speedometer, Includes English Odometer; Includes 3.5" Monochromatic Display with Personalization, Warning Messages and Vehicle Information

SEAT, DRIVER High Back with Integral Headrest, with Recline, Cloth, Manual Adjust Lumbar

SEAT, TWO-MAN PASSENGER High Back with Integral Headrest in Outboard Position, Center Fold-Down Armrest with Storage, Cloth, with Recline

MIRRORS (2) Manual Folding, Power Adjust, Heated, Black Heads and Arms, for 102" Load Width

CAB INTERIOR TRIM Classic, for Day Cab

**Includes**

: SUN VISOR (2) Vinyl

WINDOW, POWER (2) in Left and Right Doors

AIR BAG, FRONT, DRIVER SIDE

AIR BAG, FRONT, PASSENGER SIDE

AIR BAG, SIDE, DRIVER Seat Mounted, Outboard Side-Impact Airbag

AIR BAG, SIDE, PASSENGER Seat Mounted, Outboard Side-Impact Airbag

AIR BAG, SIDE CURTAIN Roof Mounted, for Front and Rear Outboard Seating Positions for Driver and Passenger Sides

AIR CONDITIONER with Heater, Single Zone

WHEELS, FRONT {Accuride 50180} DISC; 19.5x6.75 Rims, Powder Coat Steel, 4-Hand Hole, 8-Stud, 275mm BC, Hub-Piloted, Flanged Nut, with Steel Hubs

WHEELS, REAR {Accuride 50180} DUAL DISC; 19.5x6.75 Rims, Powder Coat Steel, 4-Hand Hole, 8-Stud, 275mm BC, Hub-Piloted, Flanged Nut, with Steel Hubs

(2) TIRE, FRONT 225/70R19.5 Load Range H HDR+ (CONTINENTAL), 643 rev/mile, 87 MPH, Drive

(4) TIRE, REAR 225/70R19.5 Load Range H HDR+ (CONTINENTAL), 643 rev/mile, 87 MPH, Drive

**Services Section:**

WARRANTY Standard for CV515, Effective with Vehicles Built December 3, 2018 or Later, CTS-3000A

14' Rugby Dump Body with Plow



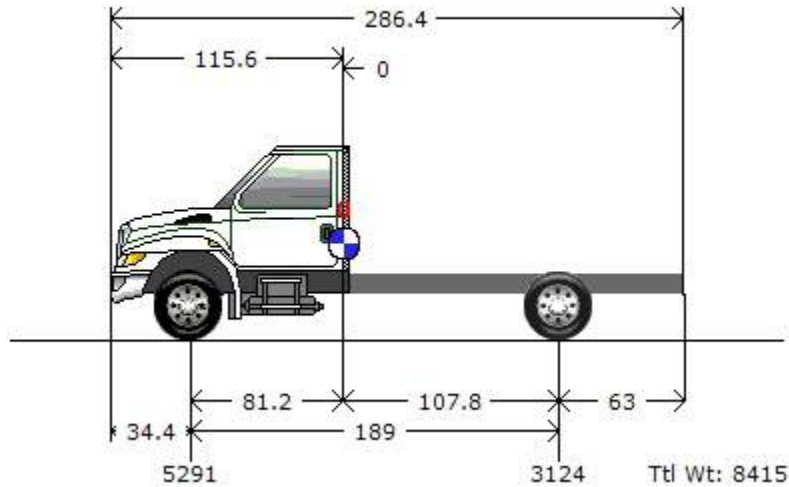

Graphics are provided as visual aids only and are not intended to represent the actual scale, shape, or color of the truck or its components. All weights are represented in lbs.

Truck			Body/Trailer			Chassis/Empty Weights	
Bumper to Axle	(BA)	34.4	Body Length	(BL)	N/A	Tractor Front Axle:	5,291
Wheelbase	(WB)	115.6				Tractor Rear Axle:	3,124
Axle to Frame	(AF)	63.0					
Axle to Back Cab	(ABC)	81.2					
Cab to Axle	(CA)	107.8					
Usable CA		107.8					
CA Reduction Adjustment		0.00					
Fuel-Diesel(Gals)		0					
DEF(Gals)		0					

Before the Cab			Cab			Payloads Chassis			Body			After the Body		
#	Weight	CG	#	Weight	CG	#	Weight	CG	#	Weight	CG	#	Weight	CG
						1	0	1						

Loads	
Payload Weight:	0
Driver:	0
Fuel-Diesel(Lbs):	0
DEF(Lbs):	0

Weight Distribution	
Total Front Axle:	5,291
Total Rear Axle:	3,124
Total Weight:	8,415

Weights and clearances in this proposal are estimates only. Navistar, Inc. is not liable for any consequences resulting from any differences between the estimated weights and clearances and the actual manufactured weights and clearances.

**Weight Distribution**

All weights are represented in lbs.

	<u>Truck</u>		<b>Total</b>
	Front	Rear	
<b><u>Chassis Weight</u></b>			
Chassis Weight:	5,291	3,124	<b>8,415</b>
Fuel:	0	0	<b>0</b>
DEF:	0	0	<b>0</b>
<b>(Curb Weight):</b>	<b>5,291</b>	<b>3,124</b>	<b>8,415</b>

**Loads**

Payloads:	0	0	<b>0</b>
Driver:	0	0	<b>0</b>
<b>Axle Totals (Gross Weight):</b>	<b>5,291</b>	<b>3,124</b>	<b>8,415</b>

**Weight Ratings**

	<u>Truck</u>	
	Front	Rear
Axle(axle capacity)	7,500	15,500
Tire(tire capacity)	8,380	16,760
Suspension(suspension capacity)	7,500	15,500
Spring:	0	
Fed Bridge Law (axle spread):	20,000	20,000

<b>Wheel Combination</b>	<b>Load</b>	<b>Limit</b>
1 - 2	8,415	45,000

Federal Total Vehicle Weight Limit: 80,000

Maximum Gross Vehicle Weight Rating (GVWR) 23,000 - Gross Vehicle Weight(GVW) 8,415 = 14,585 Reserves

**Weight Summary**

\* Distributed weights are within capacity limits

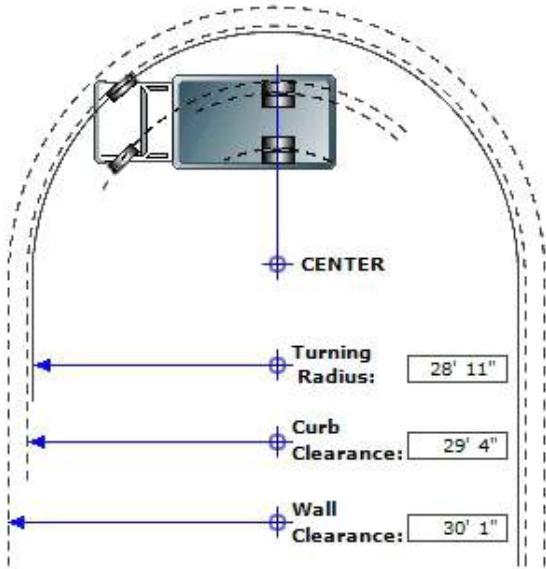

Series: CV  
 Model: CV515  
 Description: CV515 SFA  
 Model Year: 2024

**Calculation Factors**

Wheelbase: 189  
 Front Axle: 0002EWA  
 Description: AXLE, FRONT DRIVING, {Dana Spicer 60-256} Single Reduction, 7,500-lb Capacity, with Hub Piloted Wheel Mounting  
 Front Wheel: 0027DTX  
 Description: WHEELS, FRONT, {Accuride 50180} DISC; 19.5x6.75 Rims, Powder Coat Steel, 4-Hand Hole, 8-Stud, 275mm BC, Hub-Piloted, Flanged Nut, with Steel Hubs  
 Front Tire: 07789445450  
 Description: TIRES, 225/70R19.5 Load Range H HDR+ (CONTINENTAL), 643 rev/mile, 87 MPH, Drive  
 Steering Gear: 0005PSS  
 Description: STEERING GEAR, {Bosch S2 8014 Plus} Power

**Turning Radius Statistics**

General Information

Inside Turn Angle: 42 Degrees  
 Radial Overhang: 14.3

Axle Information

KingPin Inclination: 11.76 Degrees  
 KingPin Center: 60.96

**Turning Radius - Curb View**

C - Curb Contact Length: 13.21  
 CI - Curb Clearance Increment: 4.60  
 CR - Curb Clearance Radius: 29'4"  
 CH - Curb Height: 6"  
 TR - Turning Radius: 28'11"  
 TW - Tire Width: 08.70

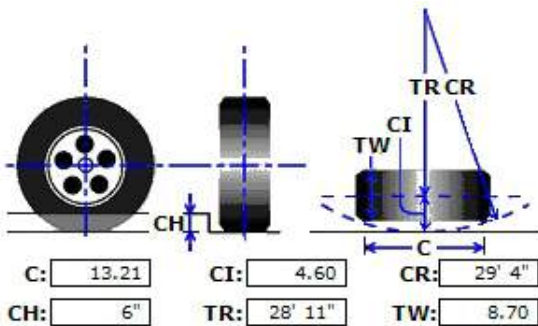

\* All Measurements are in inches, unless otherwise specified.

This information is based on engineering information available at this time. Actual figures may vary. Navistar, Inc. cannot accept liability for consequences due to this variance.

<u>Description</u>	<u>(US DOLLAR)</u>	<u>Price</u>
Total Factory List Price Including Options:		\$75,538.00
Total Freight:		\$1,950.00
Total Factory List Price Including Freight:		\$77,488.00
Total Vehicle Price:		\$77,488.00
Total Body/Allied Equipment:		\$37,249.00
Total Sale Price:		\$114,737.00
Total Per Vehicle Sales Price:		\$114,737.00
Total Net Sales Excluding Taxes:		\$114,737.00
San Benito	\$8,318.43	
Total Taxes:		\$8,318.43
Net Sales Price:		\$123,055.43

Please feel free to contact me regarding these specifications should your interests or needs change. I am confident you will be pleased with the quality and service of an International vehicle. This vehicle IS NOT available for Export. This quotation DOES NOT include license fees. These will be calculated after the vehicle is completed and weighed.

**Approved by Seller:**

**Accepted by Purchaser:**

\_\_\_\_\_  
**Official Title and Date**

\_\_\_\_\_  
**Firm or Business Name**

\_\_\_\_\_  
**Authorized Signature**

\_\_\_\_\_  
**Authorized Signature and Date**

**This proposal is not binding upon the seller without Seller's Authorized Signature**

\_\_\_\_\_  
**Official Title and Date**

**The TOPS FET calculation is an estimate for reference purposes only. The seller or retailer is responsible for calculating and reporting/paying appropriate FET to the IRS.**

**The limited warranties applicable to the vehicles described herein are Navistar, Inc.'s standard printed warranties which are incorporated herein by reference and to which you have been provided a copy and hereby agree to their terms and conditions.**

# BOARD AGENDA REPORT

Date: 4/20/2023  
Staff: Chris Tuggle

---

**SUBJECT: MNI Support Contract**

---

**RECOMMENDED ACTION:** Discussion and possible action to approve the Microwave Networks Bronze Lifecycle Support Services Program

---

**BACKGROUND AND/OR HISTORY:**

The Proteus MX radios cover 6 critical links that carry our security, control and business networks. Strawberry Operations to Strawberry Peak, Strawberry Peak to Donnells PH, Strawberry Peak to Beardsley PH, Strawberry Peak to Sandbar PH, Strawberry Peak to Mt. Elizabeth, Mt Elizabeth to Tulloch PH.

This support contract covers return and repair warranty in the event of a component defect, phone support for diagnosing radio link outages or issues. This contract covers us from today until 5-26-2024.

This is a sole source quote because it is manufacturer support.

Upcoming quote for Tri-Dam personal training in progress.

**FISCAL IMPACT:** Unbudgeted

**ATTACHMENTS:** Microwave Networks Quote \$15,223

---

**Board Motion:**

**Motion by:** \_\_\_\_\_ **Second by:** \_\_\_\_\_

**VOTE:**

**OID:** DeBoer (Yes/No) Doornenbal (Yes/No) Orvis (Yes/No) Santos (Yes/No) Tobias (Yes/No)

**SSJID:** Holbrook (Yes/No) Kamper (Yes/No) Roos (Yes/No) Spyksma (Yes/No) Weststeyn (Yes/No)



4000 Greenbriar Stafford, TX 77477  
 Ph.: 281-263-6500; Fx: 281-263-6406

**Lifecycle Support Services**

Customer: Tri-Dam  
 Contact: Eric Everhart

Sales Contact: Itai Farchi  
 System Engineer: AA  
 Quote: IF21010-50  
 Date: 3/29/2023  
 Currency: US Dollars  
 PRICE AND MATERIAL LIST

Location: CA  
 EXW: Stafford, Texas  
 Validity: 90 days  
 Delivery:  
 Payment Terms: Per Contract

Item	Model	Description	Unit Price	Total Qty	Extended Price
<b>1.00 Bronze Lifecycle Support Services Program</b>					
1.01	LSSBRONZE04	Microwave Networks Bronze Lifecycle Support Services Program for Tri-Dam Project for Year-04 (Radios purchased under Sales Order # 420208A)  Includes: Proteus MX Radios Return & Repair Warranty Proteus MX 8x5 Phone Support Proteus MX Network Health Check	\$15,223	1	\$15,223
<b>Grand Total - Bronze Lifecycle Support Services Program</b>					<b>\$15,223</b>

<b>Payment Schedule:</b>		Year Start	Year End		
BRONZELSS3	Bronze LSS for all quoted MNI Microwave Radio Products-Year 3	5/27/2022 to 5/26/2023	Included		Included
BRONZELSS4	Bronze LSS for all quoted MNI Microwave Radio Products-Year 4	5/27/2023 to 5/26/2024	\$15,223	1	\$15,223
BRONZELSS5	Bronze LSS for all quoted MNI Microwave Radio Products-Year 5	5/27/2024 to 5/26/2025			
BRONZELSS6	Bronze LSS for all quoted MNI Microwave Radio Products-Year 6	5/27/2025 to 5/26/2026			
BRONZELSS7	Bronze LSS for all quoted MNI Microwave Radio Products-Year 7	5/27/2026 to 5/26/2027			
BRONZELSS8	Bronze LSS for all quoted MNI Microwave Radio Products-Year 8	5/27/2027 to 5/26/2028			
BRONZELSS9	Bronze LSS for all quoted MNI Microwave Radio Products-Year 9	5/27/2028 to 5/26/2029			
BRONZELSS10	Bronze LSS for all quoted MNI Microwave Radio Products-Year 10	5/27/2029 to 5/26/2030			
<b>Grand Total</b>					<b>\$15,223</b>

- Notes:
- 1) Extended repair and return maintenance covers only equipment manufactured by Microwave Networks Inc.
  - 2) Warranty on all OEM or 3<sup>rd</sup> party manufactured equipment is the original manufacturer's warranty or 1 year, unless otherwise stated.
  - 3) Customer pays for freight to MNI. MNI pays for return freight. All repairs are returned ground freight service. If you require the unit returned overnight customer is responsible for the freight charges.
  - 4) This extended repair and return maintenance is for a standard repair.
  - 5) MNI will make best commercialefforts to repair or replace returned product. If a product is determined to be unrepairable, customer will be notified and product will be returned with no further obligations to MNI.
  - 6) All other terms and conditions as per Microwave Networks Inc. (MNI) Standard Terms and Conditions of Trade
  - 7) All payments are due annually, due before start date of each support year.

# BOARD AGENDA REPORT

Date: 4/20/23  
Staff: Chris Tuggle

---

**SUBJECT:** Milling machine replacement

---

**RECOMMENDED ACTION:** Discussion and possible action to approve the purchase of a new milling machine.

---

**BACKGROUND AND/OR HISTORY:**

Tri-Dam Project employs a Machinist full time that fabricates precision parts on various pieces of equipment on a regular basis and the milling machine is the most frequently used. Due to the age of equipment at Tri Dam Project many parts need to be custom fabricated in order to maintain a high level of unit reliability. Recently the milling machine experienced a breakdown and critical parts were altered/manufactured in order to return the equipment to service. Repair parts have not been available for the current machine for over 20 years according to suppliers. Bridgeport milling machines have been manufactured since 1929. They have proven to be reliable with excellent availability of parts and support.

**FISCAL IMPACT:** Budget \$30,000

**ATTACHMENTS:**

Hardinge Quote	\$28,575 includes tax & freight
WorldWide Machine Tool Quote	\$35,361 includes tax & freight
Penn Tool Company Quote	\$35,921 includes tax & freight

---

**Board Motion:**

**Motion by:** \_\_\_\_\_ **Second by:** \_\_\_\_\_

**VOTE:**

**OID:** DeBoer (Yes/No) Doornenbal (Yes/No) Orvis (Yes/No) Santos (Yes/No) Tobias (Yes/No)

**SSJID:** Holbrook (Yes/No) Kamper (Yes/No) Roos (Yes/No) Spyksma (Yes/No) Weststeyn (Yes/No)





Hardinge  
One Hardinge Drive  
Elmira, New York 14903

[www.hardinge.com](http://www.hardinge.com)

Quotation to: TRI DAM PROJECT  
Quotation Number: QUO-16048-5SJOG8  
Contact: GARY SAWYER  
Address:

Date: 4/3/2023  
Prices Valid for 30 Days

Your Hardinge Representative  
*Rachael Martin*

*[Rachael.Martin@hardinge.com](mailto:Rachael.Martin@hardinge.com)*

## **BRIDGEPORT® by HARDINGE SERIES I STANDARD MILLING MACHINES**

The Bridgeport® name is synonymous with the world's finest turret milling machines. This reputation has been established since 1938 when the first Bridgeport® Milling Machine was produced. The Series I Standard continues to fulfill the industry's need for a machine that is accurate, reliable, versatile, and easy to operate. In just over seventy years, Bridgeport® craftsmen have produced over 370,000 Series I Standard Mills. Hardinge Inc. stands behind every machine it builds with parts, service, and applications support. With these traditions in mind we are pleased to present the following quotation for your consideration and look forward to the favor of your order.



### **The Bridgeport® by Hardinge Series I Standard (Features and Specifications)**

- 3-hp (30-minute duty rated) head, 2-hp (continuous)
- Infinitely variable: Low gear: 60-500 rpm; High gear: 500-4,200 rpm
- R-8 spindle taper; Collet capacity up to 3/4"
- Inch Screws and Dials
- 360-degree rotation of Ram/Turret
- Worm and gear controls used for angular settings of the head: 90 degrees left & right; 45 degrees front & back
- 9" x 49" precision ground and hand spotted table with dual locks
- 36" of table travel; X-axis (Note 'X' axis travel is reduced to 33.5" with power feed option)
- 12" of saddle travel, Y-axis
- 16" of knee travel, Z-axis (Reduced by 1." with Chip Pan)
- 5" of quill travel with built-in power quill feed (.0015, .003, .006 IPR) Quill is 3 3/8" Dia, hard chrome plated, and hand lapped for extreme accuracy and long life. Quick release micrometer depth adjustment.
- Chrome/Nickel alloy spindle is heat treated and ground with precision bearings, preloaded and accurately spaced for maximum radial and thrust capability
- Manual feed on table, saddle, and knee
- Large, graduated, easy reading dials
- Metered, One-Shot lubrication system
- Spindle guard included standard
- Color: Bridgeport® machine tool gray
- Space & weight: 7 x 10' (2.13 x 3m) 1,930 Lbs.
- Standard electrics: 208V / 230V / 460V, 60 Hz

Hardinge Inc. stands behind every Bridgeport® by Hardinge Series I Standard Machine it builds with a full one-year parts warranty. Nationwide parts are available through Hardinge Inc. directly at 1-800-843-880 or online at [www.kneemills.com](http://www.kneemills.com).

# Series I Options

## **Machine Package:**

- Inch Screws & Dials, R-8 Spindle, Chrome Ways & Gibs, One-Shot Lube
- Inch Screws & Dials, R-8 Spindle, Chrome Ways & Gibs, One-Shot Lube, X-Axis Servo Power Feed
- Inch Screws & Dials, R-8 Spindle, Chrome Ways & Gibs, One-Shot Lube X & Y Axis Servo Power Feed  
**(Y-Axis travel stop is not available for this model)**
- Inch Screws & Dials, Erickson #30 Quick Change Spindle, Chrome Ways & Gibs One-Shot Lube
- Inch Screws & Dials, Erickson #30 Quick Change Spindle, Chrome Ways & Gibs One-Shot Lube, X-Axis Servo Power Feed
- Inch Screws & Dials, Erickson #30 Quick Change Spindle, Chrome Ways & Gibs One-Shot Lube, X & Y Axis Servo Power Feed

## **Coolant System:** (Installed Prior to Shipment)

Accu-Lube Mist Coolant System (pneumatic operations)  
Accu-Lube Mist Coolant System (w/NFPA Electrics)

## **Spindle Tooling:**

R8-Tooling Package 1 – Most Popular (see page 5)  
R8 Tooling Package 2 (see page 5)  
CoroMill 390 ½" Indexable End Mill 5/8" Shank (see page 5)  
CoroMill 390 All Purpose Inserts (Sold Individually) – Most Popular (see page 5)  
CoroMill 300 ½" Indexable End Mill 5/8" Shank (see page 5)  
CoroMill 300 All Purpose Inserts (Sold Individually) (see page 5)  
Set of R-8 Collets (11 collets, 1/8" to ¾" (1/16" increments)  
#3-2J Right-Angle Attachment (accommodates R-8 collets)

## **Power Drawbars:** (Installed Prior to Shipment)

Power Drawbar for R-8 Spindle without NFPA Electrics  
Power Drawbar for R-8 Spindle for use with NFPA Electrics  
Power Drawbar for QC#30 Spindle for use with NFPA Electrics  
Power Drawbar for QC#30 Spindle without NFPA Electrics

**NOTE:** DOES NOT INCLUDE NFPA ELECTRICS

## **Digital Readouts:**

XY Axis Acu-Rite Digital Readout 200 S (.0002" minimum Resolution)  
XYZ Axis Acu-Rite Digital Readout 200 S (.0002" minimum Resolution)

## **Hardinge 5C Indexing:**

5C Indexer w/ Control Box, Brushless Motor and Manual Closer

### **Optional Accessories:**

6" Machine Kurt Vise  
Vise Step Key Kit (11/19"x5/8")  
Swivel Base for Machine Vise  
Work Light  
Work Light (Twist-Loc Plug, used with NFPA Electrics)  
R-8 Collet Tray (Installed Prior to Shipment)  
Y-Axis Travel Stop (Can't be sold with Y-Axis Power Feed or on X&Y axis machines) (Installed Prior to Shipment)  
  
NFPA Electrics 208-234-460V, 60Hz (Installed Prior to Shipment)  
Additional Installation, Operation and Maintenance Manuals  
(One Set Included with each machine)  
Export Crating

### **R8 Tooling Package By:**



### **Package 1- Light Cutting Face Mill Package w/ Med. Sized Tools **(Most Popular)****

RA390-051R19-11M - CoroMill 390: Indexable Shoulder Face Mill – 2" ([more details](#))  
RA245-051R19-12M - CoroMill 245: Indexable Face Mill – 2" ([more details](#))  
A392.R8.05-19 020 – R8 Tooling Adapter (Arbor)  
R390-11 T3 08E-PL 1030 – Sold Individually – All Purpose Grade Inserts for CoroMill 390  
R245-12 T3 E-PL 1130 – Sold Individually - All Purpose Grade Inserts for CoroMill 245



CoroMill 390

CoroMill 245

R8 Adapter

390 Inserts

245 Inserts

### **Package 2- Edge Economy Face Mill Package w/ Med. Sized Tools**

A345-051R19-13M - CoroMill 345: Indexable Face Mill ([more details](#))  
A490-051R19-08M - CoroMill 490: Indexable Shoulder Face Mill ([more details](#))  
A392.R8.05-19 020 – R8 Tooling Adapter (Arbor)  
345R-1305E-PL 1130 - Sold Individually - All Purpose Grade Inserts for CoroMill 345  
490R-08T308E-ML 1130 – Sold Individually - All Purpose Grade Inserts for CoroMill 490



CoroMill 345

CoroMill 490

R8 Adapter 345 Inserts

245 Inserts

## Individual End Mills:

RA390-013M16-11L - CoroMill 390: ½" Indexable End Mill 5/8" Shank – **(Most Popular)**  
R390-11 T3 08E-PL 1030 - Sold Individually - All Purpose Grade Insert for CoroMill 390



RA300-013M16-07L – CoroMill 300: ½" Indexable Profile Mill -Used for  
Profiling/3D Contour 5/8" Shank  
R300-0720E-PM 1030 – Sold Individually - All Purpose Grade Insert for CoroMill 300



**TO:** TRI DAM PROJECT

**ISSUED:** 4/3/2023 1:36 PM

**EXPIRATION:** 5/3/2023

**Quote Number:** QUO-16048-5SJOG8

**Quote Revision:** 1

**ATTN:** GARY SAWYER

**SALES CONTACT:** Rachael Martin

**PHONE:** 1-209-743-2730

**DIRECT:**

**E-MAIL:** GSAWYER@TRIDAMPROJECT.COM

**E-MAIL:** Rachael.Martin@hardinge.com

Machine	Qty	Price	Total Price
SERIES I KNEE MILL-R8 SPIN-XPF Part Number: BPKMR8PF	1	\$21,000.00	\$21,000.00
<b>Installed Kneemill Options</b>	<b>Qty</b>	<b>Price</b>	<b>Total Price</b>
DRO 200S SYS 48 X&Y AXIS INSTL Part Number: BP 11810521INS	1	\$3,229.00	\$3,229.00
<b>Other</b>	<b>Qty</b>	<b>Price</b>	<b>Total Price</b>
MANUAL VISE 6 W/ 9.0 OPENING Part Number: DX6	1	\$743.00	\$743.00
			<b>\$24,972.00</b>

**Configuration Total Amount** **\$24,972.00**

**Customer Specific Items Total Amount** **\$0.00**

**Total Amount** **\$24,972.00**

Net terms: 10% down payment / Net 30 days / UCC filings may apply / Subject to Credit Approval

To accept this quotation, sign, date and return with Purchase Order: \_\_\_\_\_ DATE: \_\_\_\_\_

## HARDINGE INC. TERMS AND CONDITIONS OF SALE FOR NEW PRODUCTS

All sales of Products are subject to the following Terms and Conditions of Sale ("Terms").

**1. Definitions.** The word "**Seller**" as used herein shall mean Hardinge Inc. and its subsidiaries and the word "**Buyer**" shall mean the Party to whom the Product is sold. Seller and Buyer are collectively the "Parties". The term "**Product**" means new machines, parts and any other new equipment sold by Seller to Buyer. The word "**Contract**" means collectively (i) these Terms, (ii) any additional "Supplement to Terms and Conditions of Sale" provided by Seller to Buyer from time to time, (iii) the Buyer's purchase order (but solely with respect to quantity and identity of Products ordered and expressly excluding all other terms), (iv) any written quotation provided by Seller to Buyer and (v) invoice(s) issued by Seller to Buyer and any documentation included therewith by Seller.

**2. Contract Formation.** No agreement between the Parties shall exist until the Contract has been accepted in writing by Seller. The Contract constitutes the only agreement between the Seller and the Buyer governing the purchase of Products. Any other terms and conditions originating with the Buyer (including but not limited to any terms and conditions of the Buyer in a purchase order or referenced on the Buyer's website or in any documentation or correspondence submitted by the Buyer or any terms implied by trade custom, practice or course of dealing) are all hereby expressly rejected and shall not become part of the Contract even if Seller effected delivery of Products or rendered services without reservation. The availability of Products identified in Seller's quotation is made subject to prior sales to third parties. In any event, said quotation will become void if not accepted by the Buyer by issuing a purchase order either (i) 30 days from the date of the quotation or (ii) the date for acceptance indicated in the quotation. Seller reserves the right to hold shipment of Products until a Contract has been entered into with the Buyer. The Buyer assumes full responsibility for inaccurate or incomplete data supplied in any Contract.

**3. Prices. All prices in the Contract are subject to change by Seller without notice at any time and are based in part on market prices for Seller at the time of quotation and the applicability of the Terms set forth herein.** Without limiting the foregoing, in the event Seller incurs increased costs for component parts of the Products in order to perform the Contract of more than two percent (2%) from the market price of such component parts as of the date of quotation, Seller shall have the right to add a surcharge to reflect such actual increase in the price of producing the relevant Product under the Contract (the "**Surcharge**"). The Surcharge covers any increased costs to Seller for component parts including, without limitation, as a result of increases in the cost of raw materials, the cost of components or sub-assemblies, the cost of premium freight or expedited delivery to ensure supply from suppliers, and the cost of labor. Should the Buyer desire other or different terms, the prices may be subject to adjustment by Seller in its sole discretion. All Prices are

F.O.B. Seller's plants (either Elgin, IL 60123 or Elmira, NY 14902) for equipment boxed, crated or skidded for domestic shipment (export packing charges are extra). Prices are those in effect at the time the Contract is accepted by Seller. IF THE BUYER DELAYS SHIPMENT BEYOND THE ORIGINAL SHIPMENT DATE SPECIFIED IN THE CONTRACT, ALL OUTSTANDING AMOUNTS FROM THE BUYER UNDER THE CONTRACT ARE IMMEDIATELY DUE AND PAYABLE; THE BUYER WILL BE LIABLE FOR ALL COSTS OF STORAGE, INSURANCE, HANDLING AND OTHER COSTS AS DETERMINED BY SELLER; AND SELLER RESERVES THE RIGHT TO AMEND THE PRICES CHARGED UNDER THE CONTRACT TO MATCH THOSE IN EFFECT AT THE TIME THE SHIPMENT IS MADE. Seller reserves the right to cancel the Contract in the event that (a) any government price regulation, schedule or ceiling prescribes a price lower than Seller's price as set forth in the Contract, or in any way prevents Seller from purchasing or otherwise acquiring any commodity or service necessary to the performance of the Contract, or in any way prevents Seller from adjusting its prices when the cost of any such commodity or service is increased and, (b) in the event any major change in economic conditions renders Seller's performance of the Contract unprofitable. A Surcharge, if applicable, will be added to the invoice by Seller (and will become part of the price under the Contract) without the obligation to revise or amend the Contract or any purchase order with Buyer.

**4. Taxes.** Prices do not include any sales, use, excise, property or other taxes that may be levied on the transaction by local, state, federal or foreign governments. Any taxes Seller is required to collect from Buyer will be added to the invoice or billed separately to the Buyer.

**5. Terms of Payment (Domestic).** Unless otherwise specified in the Contract, the terms of payment will be net cash seven (7) days from date of invoice and are subject to credit approval by Seller's credit department. Unless otherwise agreed in the Contract, the terms of payment will be forty percent (40%) upon Seller's written confirmation of its acceptance of the Contract with sixty percent (60%) upon shipment from the Seller's facility. If the Contract specifically provides for acceptance testing after shipment, the terms of payment will be thirty percent (30%) upon Seller's written confirmation of its acceptance of the Contract, sixty percent (60%) prior to shipment from the Seller's facility and ten percent (10%) upon acceptance as provided in Paragraph "9". The Seller reserves the right to file a Uniform Commercial Code (UCC) Financing Statement for all machine purchases not fully paid for prior to shipment from Seller's premises. Late charges at the rate of 1.5% per month (18% annually) may be charged on past due accounts.

**6. Terms of Payment (Foreign).** Unless otherwise specified in the Contract, the terms of payment shall be as stated herein for domestic purchases and all payments to be made in United States Dollars. Seller reserves the right

to require the Buyer to post an irrevocable Letter of Credit to be established through and confirmed by a New York bank providing for payment against Seller's sight draft accompanied by a commercial invoice and Buyer's forwarding agent's receipt acknowledging pick up of shipment FOB location stated in the Contract. The Seller also reserves the right to file the applicable country equivalent of a United States Uniform Commercial Code (UCC) Financing Statement for all machine purchases not fully paid for prior to shipment from Seller's premises.

**7. Production Estimates.** Any projected production figures and performance data are estimates based on Seller's understanding of the machinability of material, amount of material to be removed, accuracy desired, available facilities, operator skill, and other specified factors affecting Production, and do not constitute a guarantee of production.

**8. Delivery; Risk of Loss; Title.** Any quoted delivery dates are approximate and only the delivery date specified in the Contract will be binding; provided, however, delivery dates are subject to revision at any time due to causes beyond the Seller's control (as notified to Buyer) including without limitation delay in receipt of Buyer's signature to the Contract or Buyer's complete specifications; fire, shortages of material, transportation delays, strikes, failure of suppliers or subcontractors to meet delivery schedules, war, riots, acts of God, epidemics, pandemics, any action by any government agency and any priority or rationing system imposed by authority of any government agency. Delivery to a common carrier or licensed trucker shall constitute tender of delivery, passing of risk of loss to the Buyer and all risk of loss or damage in transit shall be borne by the Buyer. Seller shall not be liable to Buyer for any costs, damages or expenses arising, in any way, from any late delivery or non-delivery. Seller reserves the right to stoppage in transit and to repossess equipment notwithstanding delivery to the carrier until payment in full has been made to Seller. Title to the Products will not pass to Buyer, and Buyer hereby grants a security interest to Seller in such Products (together with all of the rights and remedies of a secured party under the Uniform Commercial Code), until all Seller invoices have been paid in full. During the period of reservation of title, Buyer must, at its own cost, maintain the Products and insure them for the benefit of Seller against all risks. No claim relating to quantity, condition, loss or damage to the Products made by Buyer will be accepted by Seller unless Seller is given written notice of said claim within thirty (30) days after date of shipment and Buyer establishes that such condition, loss or damages to the Products existed prior to shipment.

**9. Acceptance.** Where the Contract expressly provides for acceptance of the Product by the Buyer (whether at Seller's plant or Buyer's facility), Seller shall notify Buyer that the Product is available for acceptance testing and Buyer shall: (i) test where appropriate and evaluate the Product to determine whether it substantially conforms to the specifications and performance requirements specifically set forth in the Contract; and (ii) will provide a written notice to Seller of its acceptance of the Product, or provide a written notice of nonconformity specifying why and how the Product does not substantially

conform to the specifications and performance requirements set forth in the Contract. Buyer will use commercially reasonable efforts to complete this acceptance testing within five (5) calendar days from Product being made available by Seller for testing, but, in any event, will provide written notice of its acceptance or rejection of the Product within ten (10) calendar days (unless another time period is specified in the Contract). If Buyer does not respond within the ten (10) calendar days' period, then the Product will be deemed accepted. If Seller receives a notice of nonconformity from Buyer, it shall promptly: (a) take such steps as are necessary to remedy the error or deficiency to ensure that the Product does substantially conform to the applicable description and criteria as set forth above; and (b) provide to Buyer a written notice of remedy. Upon receipt of a notice of remedy, Buyer may, within a subsequent ten (10) calendar day period, conduct such further tests and evaluations on the Product as necessary to determine whether the Product substantially conforms with the specifications set forth in the Contract and either finally accept or reject such Product as non-conforming. If the Product is rejected as non-conforming, Seller's maximum liability shall not exceed an obligation to either (a) repair or replacement of the defective part or Product, or, at the Seller's option, (b) accept the return of the Product and make a full refund of the amount paid by Buyer for the relevant Product. In either case, such remedy shall be the Buyer's sole and exclusive legal and equitable remedy for a Product that does not pass acceptance testing. Any return of the Product will be subject to the provisions of Paragraph "12".

**10. Material sent for Repair.** Buyer's material sent to Seller for modernization or repair or being returned pursuant to the provisions of these Terms will be delivered by Buyer, at its expense, to the repair or manufacturing plant designated by Seller where the work is to be performed. Title to the Buyer's material will remain at all times with Buyer. Risk of loss or damage to material will transfer to Seller upon its arrival at the repair or manufacturing plant and will transfer back to Buyer upon its delivery by Seller to the carrier at the repair or manufacturing plant after the work is performed. When repair work is performed by Seller at Buyer's site, title and risk of loss or damage to the Buyer's material and other property shall remain at all times with the Buyer.

**11. Warranty, Disclaimer and Remedy.** Subject to payment in full by Buyer in accordance with the terms of the Contract, Seller warrants to the original Buyer only that new Products manufactured by the Seller and sold directly by the Seller or through an authorized representative and used by the original Buyer within limits of rated and normal usage will be free from defects which are not commercially acceptable in material and workmanship for the following periods, measured from the date of shipment: (i) six (6) months for repair parts purchased after the original machine warranty expires; and (ii) twelve (12) months for all new grinding machines. Wear parts such as bearings, bellows, belts, cables, contactors, perishable tooling (quills, wheels, etc.), relays, switches and the like are not covered. For vendor supplied Products on Hardinge Grinding Group



Contracts, the warranty will be the vendor warranty or one year, whichever is shorter. This warranty shall apply only to new Products sold, installed and maintained in the forty eight (48) continental United States. Installation must take place no later than 3 months from the date of shipment. Any Product not so sold, installed and maintained shall be sold "as is" and any repairs or service shall be provided in accordance with Paragraph "15" unless otherwise expressly agreed to in writing by Seller. In no event shall the Buyer have any rights greater hereunder than if all components were manufactured by Seller. The terms of this warranty do not in any way extend to any Product or part thereof which has a life under normal usage inherently shorter than one year, secondhand Products or Products which were not manufactured by the Seller and not sold under the Hardinge Inc. trade name. Different terms and conditions are applicable to secondhand Products. Seller's obligation and liability with respect to components not manufactured by the Seller shall be limited to the extent of express warranties received by Seller from such component manufacturers unless said components are sold under the Hardinge Inc. trade name, in which case, the new machine warranty shall be applicable. This warranty is void and of no effect and Seller shall not be liable for any breach of warranty, express or implied, if the equipment or any part or component thereof shall have been repaired or altered by persons other than the Seller (unless expressly authorized in writing by Seller), or if the equipment is operated or installed contrary to Seller's instruction or subjected to misuse, negligence or accident. Written notice of any claimed defect within the warranty period must be presented to the Seller immediately upon Buyer's discovery of the defect. Seller shall have the option to inspect any parts claimed to be defective either at the Buyer's place of business or at the Seller's place of manufacture while the Product is in the claimed defective condition. No return shall be accepted unless Seller has had an opportunity to inspect the equipment or has expressly authorized the return. If the equipment defect constitutes a safety hazard, operation of the Product must be suspended until corrective action is completed. Seller, upon receipt of written notice of a claimed defect, will proceed without unreasonable delay to remedy any defect coming within the warranty which is found to exist. During the warranty period, parts found to be defective by Seller's inspection will be furnished free of charge, shipment F.O.B. Point of Origin. **THERE ARE NO OTHER WARRANTIES THAT EXTEND BEYOND THE WARRANTY HEREIN CONTAINED. THE WARRANTY STATED HEREIN IS IN LIEU OF ALL OTHER WARRANTIES EXPRESS OR IMPLIED, INCLUDING BUT NOT LIMITED TO, ANY IMPLIED WARRANTY OF MERCHANTABILITY OR FITNESS FOR A PARTICULAR PURPOSE AND IS IN LIEU OF ANY AND ALL OTHER OBLIGATIONS OR LIABILITIES ON SELLER'S PART.** No statement, oral or written, inconsistent with this warranty is binding on the Seller. No agent, employee or representative of the Seller, other than a duly authorized officer, has any authority to bind the Seller to any confirmation, representation or warranty concerning the Product beyond that specifically included in the warranty contained herein. **UNDER NO**

**CIRCUMSTANCES WILL THE SELLER BE LIABLE FOR ANY INCIDENTAL OR CONSEQUENTIAL DAMAGE OR EXPENSE OF ANY KIND, INCLUDING, BUT NOT LIMITED TO, PERSONAL INJURIES AND LOSS OF PROFITS, ARISING IN CONNECTION WITH ANY CONTRACT OR WITH THE USE, ABUSE, UNSAFE USE OR INABILITY OF BUYER TO USE THE PRODUCTS.**

Seller's maximum liability shall not exceed an obligation to either (a) repair or replacement of the defective part or Product, or, (b) at the Seller's option, accept the return of the Product and make a full refund of the purchase price. In either case, such remedy shall be the Buyer's sole and exclusive legal and equitable remedy. If the Buyer and the Seller agree that it would be in the best interest of both Parties to return the Product and refund the purchase price, the Buyer shall be liable for the rental cost of the Product for the period from the date of shipment to the date the Product is returned to Seller (the "Rental Period"). The rental cost of Product shall be based on the latest Seller rental price for renting a similar product as the Product being returned for the Rental Period. This cost shall be deducted from the purchase price refunded to the Buyer. The sole purpose of the stipulated exclusive remedy shall be to provide the Buyer with free repair or replacement of defective Products, or refund of the purchase price, in the manner provided herein. This exclusive remedy shall not be deemed to have failed of its essential purpose so long as Seller is willing and able to repair or replace defective Products, or to refund the purchase price, in the prescribed manner.

**12. Returns Procedure.** All Products returned to Seller require a Return Material Authorization (RMA) to be issued by Seller. The RMA number must be clearly printed on each returned container. Any container received by Seller without an RMA number shall be returned to sender collect. Made-to-order items, special collets, items with special bore sizes, batteries, altered or etched items are not accepted for return. Products which are returned in new and unused condition in the original package within thirty (30) days of the shipment date will be eligible for full refund less a ten percent (10%) restocking charge (minimum restocking charge of \$30.00). Returned parts must be shipped prepaid by Buyer. After thirty (30) days, new and unused parts will be accepted for return for up to three (3) months from the original shipment date with a thirty percent (30%) restocking charge applicable. After three (3) months from the original shipment date, Seller will not accept any returned Product. If the returned item is not what the Buyer ordered (as set forth in the RMA), Seller will replace the item, pay any additional shipping charges incurred and waive any restocking charge. If the seal is broken on returned printed circuit boards and the machine is out of warranty, or if the Seller's service technician did not perform the service, a two hundred dollar (\$200) testing fee shall be applicable. Before returning out of warranty printed circuit boards, Seller must be contacted for information. Not all circuit boards will be accepted for return. Seller reserves the right to inspect returned Products and to reject the return of Products in accordance with these policies. All rejected returns shall be reshipped to the Buyer at Buyer's

expense. For all returns within the U.S., call 800-843-8801 Option 2 or 607-734-2281 or fax 607-734-3886. For all other returns, call 607-734-2281 or fax 607-734-3886.

**13. Limitation of Liability. NOTWITHSTANDING ANY OTHER PROVISIONS OF THE CONTRACT AND TO THE EXTENT PERMITTED BY APPLICABLE LAW, SELLER, AND ITS SUBCONTRACTOR(S) AND SUPPLIERS AT ANY TIER, SHALL NOT BE LIABLE IN CONTRACT, IN TORT (INCLUDING NEGLIGENCE AND STRICT LIABILITY), OR OTHERWISE FOR ANY SPECIAL, INDIRECT, INCIDENTAL OR CONSEQUENTIAL DAMAGES WHATSOEVER INCLUDING, BUT NOT LIMITED TO, LOSS OF PROFITS OR REVENUE, LOSS OF USE OF EQUIPMENT OR SYSTEM, COST OF CAPITAL, COST OF TEMPORARY EQUIPMENT, CLAIMS OF CUSTOMERS OF THE BUYER, PERSONAL INJURY OR DAMAGE OR LOSS OF PROPERTY OR EQUIPMENT NOT SUPPLIED BY SELLER UNDER THE CONTRACT. THE REMEDIES OF THE BUYER SET FORTH HEREIN ARE EXCLUSIVE, AND THE TOTAL AGGREGATE LIABILITY OF SELLER, ITS AFFILIATES, AND ITS SUBCONTRACTOR(S) AND SUPPLIER(S) AT ANY TIER, WITH RESPECT TO THE CONTRACT, OR ANYTHING DONE IN CONNECTION THEREWITH SUCH AS THE PERFORMANCE, FAILURE TO PERFORM, OR BREACH THEREOF, OR FROM ANY ACTIVITY UNDERTAKEN BY SELLER WITH RESPECT TO THE PRODUCT BUYER'S MATERIAL, OR TECHNICAL ASSISTANCE, INCLUDING, BUT NOT LIMITED TO, THE MANUFACTURE, SALE, DELIVERY, RESALE, INSTALLATION, MAINTENANCE, FIELD ENGINEERING SERVICE, FIELD ADVISORY SERVICE, REPAIR OR USE OF ANY PRODUCT COVERED BY OR FURNISHED UNDER THE CONTRACT, WHETHER IN CONTRACT, IN TORT (INCLUDING NEGLIGENCE AND STRICT LIABILITY) OR OTHERWISE, SHALL NOT EXCEED THE PURCHASE PRICE FOR THE RELEVANT PRODUCT.**

**14. Indemnification.** Buyer agrees to indemnify, defend and hold Seller harmless from any and all liability, loss or damages which Seller may suffer as a result of claims, demands, costs or judgments made against Seller arising out of any use whatsoever of the Products sold pursuant to the Contract, which liability, loss or damages, claims, demands or judgments are based upon or result from (a) any alteration or modification of the Product by Buyer, Buyer's officers, agents or employees; or (b) the failure of Buyer, Buyer's officers, agents or employees to follow manufacturer's instructions, warnings or recommendations which are communicated by Seller to Buyer in any form before, during or after the date of the Contract; or (c) the failure of Buyer, Buyer's officers, agents or employees to comply with federal, state, local or foreign laws or regulations applicable to the use of such machinery or equipment, including but not limited to, the 1970 Occupational Safety and Health Act as amended; or (d) the failure of Buyer, Buyer's officers, agents or employees to properly train and instruct anyone using the Product.

**15. Repairs and Service Non-Warranty.** The cost of all servicing of Products not provided for in preceding sections of these Terms may be charged for by the Seller at a per diem rate per worker per working day plus transportation and living expenses.

**16. Cancellation.** Upon written request from Buyer to cancel all or part of a Contract, the Seller will stop all work as promptly as possible. All cancellations shall be assessed a minimum cancellation fee of 15% of the quoted purchase price to cover the cost of order processing. In addition, Seller may recover a further cancellation fee based on percentage of completion of the Product with such further cancellation charge computed on the basis of the Seller's full cost plus 15% (for all engineering work, all work in process and raw materials, all supplies and commitments made by the Seller in connection with the Contract), less such allowances as the Seller may be in a position to make for any standard components and for the balance of the material as scrap. Products that are complete on date of notification in writing to stop work or cancel shall be invoiced and paid in full and Buyer shall promptly instruct Seller as to the disposition of the Product and the Seller, if instructed, shall hold the Product for Buyer's account. All costs of storage, insurance, handling, boxing or other costs in connection therewith shall be borne by the Buyer.

**17. Property Rights.** Seller retains for itself any and all intellectual property rights in and to all designs, engineering details and other data pertaining to any Product or materials designed in connection herewith and to all rights of discovery, invention or patent rights arising out of work done for Buyer. The Buyer expressly agrees that it will not assert any intellectual property rights therein, except the rights for itself and subsequent owners to use the Product. Any prints, brochures, drawings or other information furnished to the Buyer by the Seller are intended solely for the confidential use by the Buyer and shall remain the property of the Seller and shall not be used by Buyer for any commercial purpose, including to the detriment of the Seller's competitive position.

**18. Patent Indemnity.** If any Product furnished by the Seller is rightfully claimed to infringe any United States Patent issued at the time the Contract is accepted, Seller agrees at its option: (1) to procure for Buyer the right to use the Product, or (2) to modify or replace the Product so as to avoid infringement, or (3) to accept redelivery of the Product and reimburse Buyer for the purchase price and any transportation expenses incurred by Buyer. Should any litigation be instituted against Buyer based on a claim that any Product in the condition as shipped by Seller infringes any United States Patent, Seller will undertake the defense thereof in Buyer's behalf and pay any damages and costs awarded therein against Buyer, provided Seller is given prompt written notice and is furnished with copies of all demands, process and pleadings and Buyer cooperates fully in giving Seller authority, information and assistance at Seller's expense for such defense, as well as control over the defense and any negotiations with regard to settlement. **THE**

**FOREGOING REPRESENTS SELLER'S ENTIRE AND EXCLUSIVE OBLIGATION WITH RESPECT TO ANY CHARGE OF INFRINGEMENT AND IS IN LIEU OF ANY EXPRESS, IMPLIED OR STATUTORY WARRANTY RELATING TO INFRINGEMENT. SELLER SHALL HAVE NO RESPONSIBILITY INSOFAR AS ANY PRODUCT MODIFIED BY BUYER OR MADE OR MODIFIED BY SELLER IN ACCORDANCE WITH THE CONTRACT AND BUYER SHALL INDEMNIFY SELLER IN ACCORDANCE WITH THE INDEMNITY IN PARAGRAPH "14" ABOVE FOR ANY CLAIM WHICH ARISES OUT OF SELLER'S COMPLIANCE WITH BUYER'S SPECIFICATIONS. SELLER SHALL ALSO HAVE NO RESPONSIBILITY WITH REGARD TO ANY SETTLEMENT, ADMISSION OR PROMISE MADE BY BUYER WITHOUT SELLER'S PRIOR WRITTEN CONSENT, NOR SHALL SELLER BE LIABLE FOR ANY INDIRECT, SPECIAL OR CONSEQUENTIAL DAMAGES OF ANY NATURE WHATSOEVER, INCLUDING LOSS OF PROFITS, CLAIMED TO HAVE BEEN SUSTAINED BY BUYER OR ANY USER OF THE PRODUCT ARISING OUT OF ANY CLAIM OF INFRINGEMENT.** Seller is entitled to indemnity from certain of its suppliers and the rights and options vested in Seller shall extend to such suppliers and may be exercised by them.

**19. Confidentiality Agreement.** Buyer agrees to treat in confidence any information that may be received from Seller in connection with this Contract and designated by Seller as confidential or proprietary. Buyer shall have the limited right to use such Seller proprietary information for system maintenance and operations purposes and agrees not to disclose such Seller proprietary information to any third party without prior written consent from Seller. Buyer further agrees to make such Seller proprietary information available to its employees only on a need to know basis. Where consent is granted by Seller for disclosure of any of its proprietary information, Buyer shall require the recipient to execute a confidentiality agreement approved in advance by Seller.

**20. Reservation of Rights.** Seller reserves the right to make subsequent improvements and changes in design in its Products without imposing any obligation to make such changes or improvements upon Products sold to the Buyer.

**21. Limitation of Action.** Any action based upon an alleged breach of warranty must be commenced within twelve (12) months from the date that Buyer knew or should have known of the alleged defect or breach. Any other action against Seller must be commenced within twelve (12) months from the time the cause of action accrues unless the period for action shall be extended by Seller in writing. In the interpretation of this limitation of action for breach of Seller's warranty it is expressly agreed that there are no warranties of future performance of the equipment that would extend the period of limitation herein contained for bringing an action. IT IS EXPRESSLY UNDERSTOOD THAT ANY EFFORT BY BUYER, SELLER OR AGENTS TO REPAIR ANY PRODUCT SHALL NOT EXTEND THE TWELVE (12) MONTH

PERIOD OF LIMITATION UNLESS SELLER AGREES IN WRITING. THE WARRANTY SET FORTH IN PARAGRAPH "11" APPLIES TO REPLACEMENT PARTS AS WELL AS PRODUCTS ORIGINALLY SOLD, AND NOTHING EXCEPT SELLER'S WRITTEN CONSENT SHALL EXTEND ITS OBLIGATION IN WARRANTY MORE THAN THE PERIOD SPECIFIED IN PARAGRAPH "11".

**22. Installation Costs.** All costs associated with Product installation and/or erection shall be borne solely by Buyer.

**23. Unnecessary Delay.** If the Buyer causes unnecessary delay to the Seller's turnkey, installation process or warranty service calls, the Buyer shall be liable for all costs associated with Seller's waiting time including, but not limited to, time and material costs, travel expenses and any other costs associated with Seller's requirement to wait due to unnecessary delay. This cost shall be charged at the standard service or turnkey rates and shall be added to the first invoice sent to the Buyer following the occurrence of the unnecessary delay.

**24. Interpretation.** The Contract shall be governed by and construed in accordance with the substantive and procedural laws of the State of Illinois, USA. The Parties agree to specifically exclude the application of the United Nations Convention on Contracts for the International Sale of Goods. All references to "Dollars" are to "U.S. Dollars."

**25. Reformation.** In the event that any provision of these Terms is held illegal or unenforceable under applicable law by a court of competent jurisdiction, the validity or enforceability of the remaining provisions will not be affected, provided that the fundamental terms and conditions of these Terms (including without limitation Paragraphs 2, 3, 5, 6, 8, 11, 13, 14, 18, 19, 21 and 24) remain legal and enforceable. To the extent that any non-fundamental terms and conditions of these Terms are determined by a court of competent jurisdiction to be unenforceable, the unenforceable provision or provisions may be reformed to as closely as possible effectuate the intent of Seller and Buyer.

**26. Alternate Dispute Resolution.** In the event a dispute between the Parties cannot be resolved, an appeal shall be made to a committee consisting of a corporate officer or other legal representative authorized to act on behalf of the respective Party under local law. The corporate officers or legal representatives authorized to act on behalf of the respective Party under local law shall negotiate in good faith to properly assign the disputed cost to or between the Party(s). If an amicable settlement cannot be reached after thirty (30) days, either Party may request that the issue be decided through mediation in accordance with the procedure set forth in the following Paragraph "27".

**27. Mediation:** The Parties agree that any dispute or controversy arising out of this Contract or any interpretation of this Contract which the Parties are not able to resolve themselves through negotiation shall be submitted to non-binding mediation before any other legal

action is taken. The Parties shall mutually agree upon a single third party mediator. The costs and expenses of the mediation shall be borne equally by the Parties. Mediation shall take place at Elgin, Illinois, within two (2) weeks after notification by the aggrieved Party of a request for mediation unless extended by the mediator. If the mediation does not result in an agreement acceptable to all Parties, any Party may take such other further action as it deems advisable under law or equity.

**28. VENUE. WITHOUT LIMITING THE MANDATORY ALTERNATE DISPUTE RESOLUTION AND MEDIATION PROVISIONS CONTAINED IN PARAGRAPHS 26 AND 27 OF THESE TERMS, ANY LITIGATION BASED ON THE CONTRACT, TORT, OR ANY COURSE OF ACTIONS, CONDUCT, COURSE OF DEALING OR STATEMENTS (WHETHER ORAL OR WRITTEN) OF BUYER OR SELLER, SHALL BE BROUGHT AND MAINTAINED EXCLUSIVELY IN THE STATE COURTS OF THE STATE OF NEW YORK THAT ARE LOCATED IN CHEMUNG COUNTY, NEW YORK, AND FEDERAL COURTS IN THE WESTERN DISTRICT OF NEW YORK. BUYER AND SELLER EACH IRREVOCABLY CONSENTS TO THE SERVICE OF PROCESS OF ANY OF THE AFOREMENTIONED COURTS IN ANY SUCH LITIGATION BY THE MAILING OF COPIES THEREOF BY CERTIFIED MAIL, POSTAGE PREPAID, RETURN RECEIPT REQUESTED, TO SUCH PARTY'S ADDRESS SET FORTH IN THE CONTRACT, SUCH SERVICE SHALL BECOME EFFECTIVE 10 DAYS AFTER SUCH MAILING.**

**29. WAIVER OF JURY TRIAL. BUYER AND SELLER HEREBY EACH KNOWINGLY, VOLUNTARILY AND INTENTIONALLY WAIVES TO THE EXTENT PERMITTED BY APPLICABLE LAW ANY RIGHTS IT MAY HAVE TO A TRIAL BY JURY IN RESPECT OF ANY LITIGATION ARISING UNDER THE CONTRACT.**

**30. Assignment of Contract.** Neither Party shall assign, transfer or convey the Contract or its rights, title, interest, obligations or responsibilities hereunder without the prior written consent of the other Party, which consent shall not be unreasonably withheld.

**31. Entire Agreement.** The Contract replaces all previous agreements and any course of dealing between Seller and Buyer and embodies the entire agreement between Buyer and Seller. The Parties shall not be bound by or be liable for any statement, representation, promise, inducement or understanding of any kind or nature not set forth therein. No changes, amendments or modifications of any of the terms or conditions of the Contract shall be valid unless reduced to writing and signed by both Parties.

**32. Canadian Sales.** (1) Each reference to "United States port" could be deemed to be "Canadian port"; (2) Each reference to "Uniform Commercial Code" shall be deemed to be "Personal Property Security Act"; (3) Each reference to "forty eight (48) continental United States" shall be deemed to be "Canada"; (4) Each reference to "1970 Occupational Safety and Health Act" shall be deemed to be "applicable Canadian, Provincial, and

Territorial occupational, safety, and health laws and regulations"; (5) Each reference to "United States Patent" shall be deemed to be "Canadian or United States Patents."

**33. Mexican Sales.** (1) Each reference to "United States port" shall be deemed to be "Mexican port"; (2) Each reference to "Uniform Commercial Code" shall be deemed to be "Codigo DeComerico"; (3) Each reference to "forty-eight (48) continental United States" shall be deemed to be "Mexico"; (4) Each reference to "1970 Occupational Safety and Health Act" shall be deemed to be "applicable Mexican, Territorial occupational, safety, and health laws and regulations"; (5) Each reference to "United States Patent" shall be deemed to be "Mexican or United States Patents."

**34. European Sales.** (1) Each reference to "United States port" shall be deemed to be a port in the relevant European country; (2) Each reference to "Uniform Commercial Code" shall be deemed to be a reference to comparable European legislation protecting the interests of creditors; (3) Each reference to "forty-eight (48) continental United States" shall be deemed to be a reference to the relevant European country; (4) Each reference to "1970 Occupational Safety and Health Act" shall be deemed to be comparable European legislation regarding occupational, safety, and health laws and regulations; (5) Each reference to "United States Patent" shall be deemed to be to United States Patents or patents in the relevant European country (if applicable).

**35. Asian Sales.** (1) Each reference to "United States port" shall be deemed to be a port in the relevant Asian country; (2) Each reference to "Uniform Commercial Code" shall be deemed to be a reference to comparable legislation protecting the interests of creditors in the relevant Asian country; (3) Each reference to "forty-eight (48) continental United States" shall be deemed to be a reference to the relevant Asian country; (4) Each reference to "1970 Occupational Safety and Health Act" shall be deemed to be comparable legislation regarding occupational, safety, and health laws and regulations in the relevant Asian country; (5) Each reference to "United States Patent" shall be deemed to be to United States Patents or patents in the relevant Asian country (if applicable).

**HARDINGE INC.**

**One Hardinge Drive, Elmira, NY 14903 USA**

# WORLDWIDE MACHINE TOOL

614-255-9000  
9000 Cotter St. - Lewis Center, Ohio 43035  
worldwidemachinetool.com

March 2023

## New Bridgeport Series 1 Vertical Milling Machine

### FEATURES:

- Chrome Plated Ways & Gibs
- One Shot Lube
- Variable Speed Drive System
- Back Gear For Heavy Milling
- Dovetail Ways
- Manual Draw Bar
- Power Down Feed To Spindle



### SPECIFICATIONS:

Table Size .....	9" x 49"
Longitudinal Travel .....	36"
Cross Travel .....	12"
Knee Travel .....	16"
Quill Travel .....	5"
Spindle Taper .....	R-8
Spindle Speeds .....	60-4,200 RPM
Table Weight Capacity ....	750 Lbs.
Spindle Motor .....	2 H.P.
Machine Weight .....	1,950 Lbs

### Optional Accessories:

A. 2 Axis Digital Readout - Installed ...	\$3,075.00
B. X Axis Servo Power Feed - Installed	\$1,300.00
C. 6" Kurt Vise	\$895.00
D. Shipping To Strawberry, CA 95375	\$2,950.00

Note: Machine ships on a flat bed, air ride, tarped truck

MODEL:  
Series 1

BASE PRICE:  
\$24,950.00

Terms: Check With Order  
F.O.B. Factory

**Total Package Price ... \$33,170.00**



**\* \* \* Q U O T E   O R D E R \* \* \***

PENN TOOL COMPANY  
 1776 SPRINGFIELD AVENUE  
 MAPLEWOOD NJ 07040-2965  
 Phone: 800-526-4956  
 Fax : 973-761-1494

Quote # : Q29325  
 Quoted : 04/11/2023  
 Required: 04/12/2023  
 Division: 1  
 Branch : 1  
 Page : 1  
 Tr Type : QO

<b>SOLD TO:</b> 270290 TRI DAM PROJECT 31885 OLD STRAWBERRY RD STRAWBERRY, CA 95375	<b>SHIP TO:</b> RICH ENNIS TRI DAM PROJECT 31885 OLD STRAWBERRY RD STRAWBERRY, CA 95375
--	---

Via: TRUCK SHIP	Taken By: terry	Cust PO#:
FOB:	Sls Rep : NONE	Terms : PREPAID
Frt: Prepaid and Add	Job No. :	
Taxable: N	Tax ID : EXP	Required: 04/12/2023

LINE	ITEM / DESCRIPTION	QTY	UM	UNIT PRICE	PC	EXTENSION
10	RL30-3061101CS BRIDGEPORT 9 X48 VAR SPD MILL PACKAGE 3 PHASE 230 VOLT RL30C-3061101CS	1	EA	32495.00	EA	32495.00
MID TO END OF MAY AVAILABILITY (MACHINE 230 VOLT)						
SUB TOTAL						32495.00
FREIGHT						1070.00
-----						-----
TOTAL						33565.00

QUOTE EXPIRES: 05/11/2023	BUYER:	DATE:
---------------------------	--------	-------



Your Partner In Precision Since 1968

Search by Keyword, Part Number, etc...

866-270-3568



SHOP / PRODUCTS

MANUFACTURERS

CUSTOMER SERVICE

REQUEST A QUOTE

AVIS DE NOS CLIENTS



Hover to zoom

3.8 Google Customer Reviews



1

ADD TO CART



Get \$5 Off

Bridgeport Series I - 9" x 49" 3HP Variable Speed Milling Machine Package

Bridgeport Milling Machine with Accessory Package as Shown:

- Acu-Rite® new 203 Series, 2 axis digital readout
- Kurt DX6 6" , Kurt DX6 Anglock Machine Vise 6" x 9" Opening
- 11 Pc. R8 collet set with holder
- Power Table Feed "X" Axis

Series I Standard Features Include:



# BOARD AGENDA REPORT

Date: 4/20/23  
Staff: Summer Nicotero

---

**SUBJECT:** Cybersecurity Audit Preparation

---

**RECOMMENDED ACTION:** Discussion and possible action to authorize the General Manager to sign the Professional Services Agreement with Archer Energy Solutions, LLC.

---

**BACKGROUND AND/OR HISTORY:**

Tri Dam Project was notified by FERC that we will be subject to a Cybersecurity audit. Documentation requests have been sent and are due to FERC by the end of July. An on-site audit is scheduled to follow in late August. Staff has reached out to a well-known consulting firm comprised of former NERC and FERC staff who are highly specialized in the cyber-audit requirements. They have submitted a phased proposal to help staff prepare documents, conduct a gap analysis, and train for ongoing compliance.

Staff anticipates that this investment in our cybersecurity program will set Tri Dam up with the knowledge and ability to remain compliant within the cybersecurity realm as FERC rolls out the next phase of their standards later this year.

**FISCAL IMPACT:** Unbudgeted

**ATTACHMENTS:** Archer Energy Solutions Proposal \$67,600

---

**Board Motion:**

**Motion by:** \_\_\_\_\_ **Second by:** \_\_\_\_\_

**VOTE:**

**OID:** DeBoer (Yes/No) Doornenbal (Yes/No) Orvis (Yes/No) Santos (Yes/No) Tobias (Yes/No)

**SSJID:** Holbrook (Yes/No) Kamper (Yes/No) Roos (Yes/No) Spyksma (Yes/No) Weststeyn (Yes/No)



# ARCHER

Archer Energy Solutions, LLC



**PREPARED FOR:** Tri-Dam Project

**SUBMITTAL:** April 10, 2023

**PROPOSAL –** Gap Assessment and Audit Support

CONTACT

Roslyn Barranca

Account Manager

416.779.4337

[r.barranca@archerint.com](mailto:r.barranca@archerint.com)

## Table of Contents

Transmittal Letter.....	2
Qualifications.....	3
Firm Introduction.....	3
Company Experience .....	3
Experience .....	4
Critical Infrastructure Protection (CIP) Reliability Standards.....	4
Internal Controls.....	4
Audit Readiness .....	4
Gap Assessment and Audit Support – Our Approach .....	6
Project Kick-off.....	7
Task 1 – Gap Analysis.....	7
Task 2 – Gap Analysis Written Report.....	8
Task 3 – Work Plan Development.....	8
Archer Project Staffing .....	9
Investment .....	11
Appendix A: Team Resumes .....	12

## Transmittal Letter

April 10, 2023  
31885 Old Strawberry Rd  
Strawberry, CA 95375  
United States

Dear Ms. Nicotero,

Thank you for the opportunity to submit a proposal in response to your expressed need for professional services to support The Tri-Dam Project (Tri-Dam) with your gap assessment and audit preparation. Archer is confident we can provide exceptional compliance documentation support to your team.

First and foremost, our core tenets: **Honesty, Integrity, and Value**. We give you the straight story in plain terms with actionable advice customized for your organization and specific needs.

Archer Energy Solutions, LLC (Archer) has extensive experience providing regulatory compliance services to electric utilities throughout North America. We have assisted many companies in becoming “audit ready” and maintaining the NERC/Regional Entity compliance required management activities through practical approaches to achieve, maintain and sustain compliance. Further, we take the time to get to know your corporate culture and evaluate the existing skillsets as well as in-house tools to deliver custom-fit and cost-effective approaches for your distinct organization. We emphasize that our methods are not solely focused on regulatory checkboxes. Archer is the only firm with the expertise and insight to successfully advance your organization to a state that is both compliant, more resilient, and secure.

**We stand by our reputation as the most qualified firm to carry out the proposed tasks and we take immense pride in our staff.** Ours is the sole consultancy managed by, and stocked with, former Federal Energy Regulatory Commission (FERC), Regional Entity, and utility staff with over 150 combined years immersed in the NERC Regulatory standards, and **over 450 NERC audits on the record**. Most of our compliance consultants have participated in the NERC CIP and/or O&P drafting teams, implemented the standards at utilities (Registered Entities), or held responsible for auditing the standards as the compliance enforcement authority (Regional Entities). All our specialists are carefully selected for their complementary skill sets, deep knowledge of the industry and respective regulations as well as their ability to maintain the highest degree of integrity in their professional conduct. You simply will not find a more experienced firm in the business. *The resumes of the proposed consultants can be found in Appendix A.*

We appreciate this opportunity to put our unique blend of experience, knowledge, and professionalism to work for TriDam. Our goal is to provide you with such high-value service and deliverables that you will not only bring us back as a long-term partner, but you will recommend us to your peers. If you have questions about this proposal or our qualifications, please feel free to email me anytime.

Sincerely,

***Roslyn Barranca***

Roslyn Barranca  
Account Manager  
416.779.4337  
r.barranca@archerint.com

## Qualifications

### Firm Introduction

Archer's roots go back to 2001, when our founding Partners crossed paths at a large electric utility in the Pacific Northwest. At that time, mandatory reliability standards were just starting to form for the electric sector. This was at the beginning of the shift in attention the electric sector received from executive management, government officials, and other interested parties. Security practices in general, particularly in operations, were all in their infancy and reliability regulations were at a rapid pace of maturity. In 2014, the partnership that would establish Archer was formed.

The electric sector, critical infrastructure, along with the world of reliability and security has grown greatly since then. Today, Archer continues its service through unrivaled strategic and tactical advice in, but not limited to, **cyber security, physical security, regulatory compliance, electrical engineering, government affairs, witness preparation, disaster recovery, continuity of operations, emergency management, information technology, industrial controls systems, and workforce development**. Archer is the leader in NERC Compliance for both the Critical Infrastructure Protection (CIP) and Operations and Planning (O&P) Reliability Standards practices.

### Company Experience

We lead the industry through several advantages over our competition:

#### 1. We manage the largest living NERC compliance knowledge base

Using Archer to support your organization means you have direct access to all of Archer's consultants through a live knowledge base network in use as part of our standard operating procedures. Even though we like to think we know it all, none of us possibly could! With that in mind, Archer developed a means for our consultants to stay connected to get consensus-based answers to questions that make us put on our thinking caps from time to time. Through this strong interconnection of all our consultants, Archer is greater than the sum of its parts.

#### 2. Our methods lead to sustainable success for our clients

The output of security and on-going operations should be in a compliant state but with the NERC Reliability Standards that is not always the case. We have been working with utilities since the beginning of the CIP Reliability Standards (even before the Urgent Action Standards 1200) and the O&P Reliability Standards to help address the associated complexities and often found, evidentiary burden. The work efforts Archer has performed are numerous and have helped many utilities through exceedingly demanding situations including recovery from poor audit results, negotiations with settlement proceedings, self-report/mitigation plan support, audit preparedness at the "11th hour" and many other compliance-related challenges.

Archer utilizes the current NERC Compliance Monitoring and Enforcement Program (CMEP) and reviews the client's compliance history (e.g., repeat violations, number of audits, risk impact rating, previous Areas of Concern) and apply our knowledge of the Region's historic approach and known approaches to provide the best possible forecast of which Reliability Standards will be most susceptible to audit.

Archer reviews and stays abreast of enforcement analysis and violation statistics as published by NERC and is abreast of the Inherent Risk Assessment (IRA) process to further assist clients in their Reliability Standard evaluations.

## Experience

### Critical Infrastructure Protection (CIP) Reliability Standards

Archer has conducted numerous gap analyses and mock audits, both off-site and on-site, that reviewed clients' compliance evidentiary material associated with the CIP family of Reliability Standards.

Archer Understands that TriDam is looking to partner with a firm that is an expert in NERC CIP and NERC O&P compliance and has demonstrated its success with other companies similar in scope and size to TriDam. Archer also understands that TriDam is looking for a partner that has the availability, and leadership and will prioritize the work of TriDam. Archer has put together a team of professionals that look forward to partnering with TriDam to continue to mature and improve the overall compliance, resiliency, and security of its important assets.

The best way to ensure your document content at all levels will exceed the scrutiny of an audit is to have it reviewed by individuals, which are former auditors, have been through many audits, and have spent time working for utilities in varying compliance roles. Archer employs more former auditors than anyone else and can center a team around the individual needs of TriDam. We know that excellent documentation is the staple of all compliance programs. Archer's proven approach, template, and style will help make sure that your content is exactly what your team will need to work through an audit

No other firm has Archer's experience regarding NERC Compliance. **Archer has nine (9) former NERC/FERC regulators on our team to support you.** Individually and technically, our team is experienced and credentialed as engineers, technical experts, and hands-on experience. Most of our resources have been auditors, utility security and compliance employees, and long-term consultants, giving them the experience and expertise needed to partner with TriDam.

Prior to forming Archer, Archer leadership and other team members have held high-level positions in many utility companies developing and leading cyber, physical, and compliance teams to deliver and execute organizational strategies.

### Internal Controls

Over the last two years, the compliance enforcement teams have been increasing their focus and conversations on internal control programs. Specifically, the ERO has made internal controls an integral part of the overall compliance expectations. While having a good internal controls program is part of a mature cybersecurity focus, it is now expected as part of the compliance conversation including compiling the Internal Controls Data Collection Template (ICDCT). Archer has extensive experience with the following tasks and work efforts:

- Internal Control Program Review
- Internal Control Evaluation and Gap Assessment
- Internal Control Template Development for documenting, testing, and evaluating controls as needed
- Development of Project Plan
- Assist in the creation of evidentiary artifacts for those identified in the Gas Assessment
- Conduct an Internal Control Evaluation (ICE) for the internal controls
- Provide any recommendations to management for processes and tools for Internal Controls
- Train the team and subject matter experts on internal controls

### Audit Readiness

Archer works with organizations across North America to help them develop their compliance strategy, mature their organization, and ensure they work towards a state of always being audit ready. Archer leverages former auditors, FERC staffers, and other specialized resources to work with our clients on a tailored approach. We assist our clients through a variety of engagements based solely on their needs and thorough risk assessment.

With over 450 actual audits performed as auditors for a compliance enforcement authority (CEA) and mock audits all over North America, we have the experience and working knowledge to help you. Our NERC O&P and CIP services include diverse options, including but not limited to the following:

- Gap Analysis
- Mock Audits
- Procedure/Process development
- Standard-specific compliance guides development
- Internal Controls Evaluations (ICE)
- Internal Control development
  - Including the development of client's Internal Controls Data Collection Template (ICDCT)
- Staff augmentation for CIP and/or O&P
- Engineering Support
- Compliance program development
- Self-report, mitigation plan, self-certification management/support
- Reliability Standard Audit Worksheet (RSAW) preparation (review, re-write or creation)
- Audit preparation (evidence collection and packaging)
- Training: Reliability Standards; Subject Matter Expert (SME)/Witness interview; security awareness; hands-on security
- Inherent Risk Assessment (IRA)
- Audit Support (during an actual audit)
- Version transition planning
- Documentation only reviews
- Enforcement settlement consultation and support
- Cybersecurity vulnerability assessments (IT/OT assessment, pen-testing)
- Inventory management (initial and ongoing maintenance)
- Secure network design; network implementation; network diagraming
- Security project/program management
- Security gap assessments
- Disaster recovery & incident response exercises
- Security program documentation reviews/creation
- Security maturity assessments
- NIST Cyber Security Framework Alignment

## Gap Assessment and Audit Support – Our Approach

This statement of work expresses Archer’s commitment to providing Tri-Dam with compliance documentation support and guidance in the coming year ahead. The Archer team proposes a holistic and staged approach to support Tri-Dam with a comprehensive gap assessment, in-person training and audit preparation support.

Stage	Hours
<b>On-Site Gap Assessment</b>	<b>48</b>
<b>Live NERC Compliance Training On-Site</b>	<b>32</b>
<b>Deliver Gap Assessment Report and Roadmap</b>	<b>20</b>
<b>Review Internal Audit Checklist from WECC</b>	<b>40*</b>
<b>TOTAL ESTIMATED HOURS</b>	<b>140</b>

\* This number of hours is an estimate of the time needed, however there may be less time or more time needed and will be communicated to Tri-Dam.



For the most comprehensive support, the Archer team has proposed a secondary project focused on audit preparations and remediation based on the findings of the gap assessment.

Stage	Estimate Number of Hours
<b>Preliminary Audit Preparations/Remediation</b>	120*
<b>TOTAL ESTIMATED HOURS</b>	<b>120*</b>

\* This number of hours is an estimate of the time needed, however, there may be less time or more time needed and will be communicated to Tri-Dam.

## Methodology: Technical Approach and Project Plan

Archer will perform a third-party gap analysis that will include a sufficient review of TriDam registration policies, programs, plans, procedures, and evidence in order to evaluate strict compliance with the NERC CIP Standards. The analysis period for this assessment will be determined by TriDam and communicated to Archer prior to the commencement of services.

Archer's role in this work is to assist TriDam in its review of internal compliance associated with applicable NERC Standards, and to perform the work described above in the time allotted and is not intended to guarantee TriDam's conformity. As such, Archer accepts no liability for violations that result from NERC, WECC, or other regulatory actions against TriDam.

### Project Kick-off

#### Joint Kick-Off Conference Call

TriDam and Archer will hold a kick-off webinar/teleconference to discuss Archer's gap analysis process, including how file transfer will take place and set all expectations both from a consultant and client perspective as well as confirm the planning at a date to be determined. Catrina Martin of Archer will work with TriDam to schedule this kick-off teleconference at a time mutually acceptable to both parties.

#### Data Submittal via Secure File Transfer

TriDam will provide a secure method to transfer all documentation. This information will be stored securely at all times (i.e., in transit and at rest) during the engagement. Archer currently has a secure electronic exchange site, Citrix ShareFile, which can be utilized for all data transmission and storage if preferred by TriDam.

#### Gap Analysis Data Submittal

TriDam will upload all evidentiary material it has to demonstrate compliance with the above Reliability Standards. TriDam will include registration policies, programs, plans, procedures, etc. TriDam should provide all relevant evidentiary material it feels demonstrates compliance without providing excessive evidence (i.e., dump trucking). It is envisioned that this material will be uploaded within fifteen (15) business days of project kick-off.

### Task 1 – Gap Analysis

#### Evidentiary Material Review

Archer will review RSAWs, policies, procedures, and other documentation ("evidence") TriDam will provide to show compliance. It is envisioned that this off-site review will be conducted over five (5) business days.

#### Data Requests

Since this is a gap analysis and not a true mock audit, in lieu of issuing formal data requests, Archer will reach out to appropriate TriDam compliance team members to obtain further direction/answers, as needed.

## Task 2 – Gap Analysis Written Report

Archer will provide TriDam each with one (1) electronic version of a report and any additional documentation as applicable. Archer shall deliver this draft report within five (5) business days following the conclusion of the off-site gap analysis. The report will be in Word format and will contain the following:

### An Executive Summary

An assessment and gap analysis for each in-scope Reliability Standard and requirement. This will include comments on the completeness of the documentation and evidence provided to support compliance with the Reliability Standard, specific recommendations for closing gaps, improving evidence presentation and organization, and process improvement.

## Task 3 – Work Plan Development

Once Archer has delivered “final” reports to TriDam, Archer will immediately proceed with developing a work plan with associated cost estimates and schedule for completion to address any deficiencies found through the NERC CIP Gap Analysis process.

### Draft Work Plan

Once Archer has developed a draft Work Plan, it will be delivered to TriDam via the secure file transfer method agreed upon at the beginning of this project. Catrina Martin of Archer will work with TriDam’s POC to schedule a teleconference/webinar to discuss the draft Work Plan.

### Draft Work Plan Teleconference/Webinar

TriDam and Archer will hold a webinar/teleconference to discuss Archer’s draft work plan, associated cost estimates, and schedule for completion. Archer and TriDam will discuss and agree upon whether this work will be conducted off-site or on-site during this teleconference.

Any remediation assistance provided to TriDam will be conducted on a timely and material basis so only actual hours worked will be billed to TriDam for this phase.

### Deficiency Remediation Efforts

Once the Work Plan has been approved by TriDam, Archer will proceed as follows:

- Work closely with TriDam staff to ensure approval and implementation of any work plan or task.
- Develop revisions to existing policies, procedures, and forms as required.
- Enhance administrative processes and procedures as required to collect and maintain objective evidence.
- Work with TriDam staff on an ad-hoc basis for any questions that may arise relating to compliance with new or current NERC CIP/O&P requirements.

### Audit Preparation

At Archer, we value a collaborative approach in every training we deliver. We understand that each client has unique experiences and varying degrees of exposure to audits. We will work closely with you to determine the most suitable delivery format, whether it's through joint and individual sessions or a combination of both. Our team of experienced former auditors will assess your team's skills and knowledge and develop a tailored training program that meets your specific needs. By leveraging our expertise and insights, we can equip your team with the necessary tools and knowledge to excel in their roles, improve compliance posture, and better protect critical infrastructure.

### Joint SME Witness Preparation Session

Archer's team will conduct a comprehensive Joint SME Witness Preparation Session to provide guidance on how to prepare for audits, including dos and don'ts and what to expect during questioning by an auditor. This session will also cover WECC's current approach to handling off-site interviews. The training will be conducted via webinar/teleconference and is expected

to last for approximately 2 hours. Our experienced trainers will work with your team to ensure that they are fully prepared and equipped to handle any potential audit-related challenges.

### **Individual SME Witness Preparation Sessions**

Archer understands the importance of providing individualized training to each Subject Matter Expert (SME) for CIP and O&P Reliability Standards to ensure a successful formal WECC compliance audit. Our experienced auditors will conduct individual SME Witness Preparation Training sessions for each standard outlined in the formal WECC audit. During each session, our auditors will take on the role of the auditor and provide questioning that SMEs can expect during a formal audit. This approach enables our SMEs to be well-prepared and confident during the audit.

Archer's training sessions are designed to be comprehensive and thorough. We believe that feedback is essential for improvement and will take off our "auditor hat" during the last 10 minutes of each interview session. This will allow us to provide constructive feedback to each SME, highlighting areas where they excelled, such as being well-prepared and knowledgeable on the subject, and areas where they need improvement, such as being unclear or lacking knowledge on a particular topic. Our approach to individualized training will ensure that each SME is equipped with the necessary skills and knowledge to succeed during the formal WECC compliance audit.

## Archer Project Staffing

The most impressive aspect of Archer aside from the leadership team is the knowledge, talent, and experience of our staff. When you hire Archer, you are hiring the collective knowledge and "brain trust" of the entire team! With our identified resources, we have put together a team that has a proven track record of success at many utilities across the country. You simply will not find another company out there that has the talent that Archer has amassed with the success we repeatedly deliver to all clients.

Archer staff have managed and supported various compliance and security projects for NERC Registered Entities within the Texas RE, MRO, RF, WECC, SERC, and NPCC. Archer has a strong and diverse team of consultants. Our key differentiator is the quality and skill of our consultants, all of whom are very carefully selected for their integrity, experience, and professionalism. Archer proposes the following possible project team members for this project (resumes are included in Appendix A).

### **Gap Assessment and Audit Preparation Team**

- **Bryan Carr**, Managing Partner | Project Lead

Bryan Carr is a Senior Security Consultant to the energy industry with eight years of experience in physical and cyber security compliance and auditing, also representing Archer Security Group in Portland, Oregon. Mr. Carr is a Subject Matter Expert for all CIP v5 compliance standards with emphasis on BES Cyber System classification, physical security, access control and monitoring, incident response, disaster recovery, and physical security for substations. Having performed 100+ performance audits, Mr. Carr's has a vast knowledge of infrastructure, software, and cyber security capabilities of industrial processes, SCADA, and distributed control systems.



For four years, Mr. Carr was Senior Compliance Auditor, Cyber & Physical Security at the Western Electricity Coordinating Council (WECC), a regional entity responsible for coordinating and promoting Bulk Electric System security and reliability in the Western Interconnection. It is the largest and most diverse of the eight regional entities that have Delegation Agreements with the North American Electric

Reliability Corporation (NERC). Mr. Carr led and participated in over 100 CIP v3 audits and 10 CIP v5 transition audits, including spot checks and investigations, of electric utilities across the Western region of the U.S. and British Columbia. He observed, evaluated, and documented compliance practices, methods, and results for over 100 transmission substations, transmission control centers, and generation facilities, and was selected to represent WECC on joint audits with other NERC regions.

- **DJ McCarty, Senior Compliance Consultant**

DJ McCarty is a seasoned business professional with experience in regulatory compliance, risk identification, and internal controls evaluations since 2014. He is able to develop policies and procedures companies need to demonstrate compliance with applicable regulations and laws. He is effective at performing compliance assessments, internal audits, investigations into violations, inherent risk assessments, internal controls evaluations, and compliance program development.



### **Project Coordinator**

- **Catrina Martin, Chief of Staff | Project Management**

Catrina Martin is an accomplished administrative professional with a strong background in management, oversight, and administrative assistance. Ms. Martin has over 19 years of experience in the industry. Ms. Martin was previously employed by Utility System Efficiencies, Inc. (USE) from 2007 through 2016 and Western Electricity Coordinating Council (WECC) from 2002 through 2007. Ms. Martin joined Archer Energy Solutions, LLC (Archer) in October 2016. At Archer Ms. Martin is directing and coordinating a team of industry experts and assisting electric utilities and other stakeholders in the electric power industry achieve and document their compliance with mandatory NERC and Regional Entity Reliability Standards through overall project management and client support. Ms. Martin's experience in the compliance area was achieved through her years of involvement with WECC.

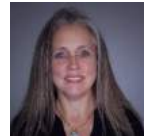

## Investment

Archer is pleased to offer the services listed below:

Project	Estimated Investment from TriDam
Gap Assessment	<u>\$ 36,400</u>
Preliminary Audit Preparations and Remediation	<u>\$ 31,200</u>

Archer anticipates a blend of hybrid and on-site work, but if travel is requested, Tri-Dam shall reimburse Archer for all reasonable and necessary expenses that Archer incurs in performing the services in this proposal, including travel expenses incurred by Archer. Tri-Dam shall pay lodging, airfare and ground transportation expenses at actual cost to Archer, receipts for which shall be provided to Tri-Dam. If Archer incurs mileage, it shall be paid by Tri-Dam, at current IRS rate<sup>1</sup> as of the time Services are rendered. Archer calculates meals and incidentals at GSA *per diem* rates<sup>2</sup> for the location where services are rendered. Any applicable taxes or third-party service charges incurred in connection with the services (except for taxes imposed on income) will be billed to, and paid by, Tri-Dam in addition to fees and expenses.

<sup>1</sup> <http://www.irs.gov/pub/irs-drop/n-12-01.pdf>

<sup>2</sup> <http://www.gsa.gov/portal/category/21287>

## Appendix A: Team Resumes

**BRYAN CARR**

Senior Security Consultant

**ACADEMIC BACKGROUND**

Bachelor of Science – Construction Management Technology, Weber State University, Ogden, Utah - 2007

**PROFESSIONAL EXPERIENCE**

Bryan has more than 10 years of experience in physical and cyber security compliance and auditing. He holds the Certified Information Systems Auditor (CISA) credential and the Certified Information Systems Security Professional (CISSP) certificate.

**Archer Security Group****2016-Present**

- **Senior Security Consultant.** A Subject Matter Expert for all CIP v5 compliance standards with emphasis on BES Cyber System classification, physical security, access control and monitoring, incident response, disaster recovery, and physical security for substations. Having performed 100+ performance audits has a vast knowledge of infrastructure, software and cyber security capabilities of industrial processes, SCADA and distributed control systems.

**Western Electricity Coordinating Council****2012-2016**

- **Senior Compliance Auditor – Cyber & Physical Security.** Led and participated in over 100 CIP v3 audits and 10 CIP v5 transition audits, including spot checks and investigations, of electric utilities across the Western region of the United States and British Columbia. Visited over 100 transmission substations, transmission control centers, and generation facilities to observe, evaluate, and document compliance practices, methods, and results. Developed subject matter expertise across all CIP v3 and v5 compliance standards with emphasis on BES Cyber System classification, physical security, access control and monitoring, incident response, disaster recovery, and physical security for substations.
  - **Audit Expertise** – Conducting and leading performance audits, understanding and evaluating compliance cultures, identifying risks and weaknesses within a compliance organization and the solutions necessary to remedy those risks and weaknesses. Responsible for audit scheduling & resource planning, CIP v3 and v5 audit approach development and documentation, and presentation development. Key team member for Inherent Risk Assessments, Internal Controls Evaluations, and other risk-based monitoring processes while providing input and feedback to improve processes. Selected to represent WECC during joint audits with other NERC regions.
  - **Additional Duties** – Review of and input to department budget; serve as a member of the enterprise risk management team; interviewing and providing hiring decision input for potential employees; training and mentoring new employees; annual resource planning and scheduling; national-level participant in initiatives to draft, implement, and audit new compliance standards and requirements; led and implemented initiatives to increase efficiency and effectiveness of audits by streamlining audit processes, procedures, and approach; created and delivered over 30 presentations on both technical and non-technical topics to large meetings (250+) of external stakeholders.

**PacifiCorp****2008-2012**

- **Compliance Program Manager – NERC CIP Compliance.** Responsible for the development, implementation and maintenance of a NERC CIP v3 compliance program encompassing 12 critical assets and over 1,500 critical cyber assets. Developed and maintained a suite of policy, process and procedure documentation. Established as a subject matter expert for all CIP Standards and their application to industrial process, SCADA and distributed control systems. Actively involved in securing and documenting new and existing critical cyber assets through the application of cyber security hardening procedures and physical security measures. Routinely travel to critical asset facilities to conduct training, perform assessments and promote a culture of compliance.
  - **Assessment and Audit for Generation and Control Center Facilities** – Responsible for: performing routine hardware and software audits of critical systems to ensure compliance with established standards, policies, procedures, and requirements; overseeing vulnerability and other internal assessments to determine audit readiness and overall compliance position; developing remediation and mitigation plans to address deficiencies and monitor progress of such plans; reviewing and maintaining storage of

- documentation and evidence required to demonstrate compliance and ensure that the retention of all documentation meets regulatory requirements. Actively monitor regulators and their audit approach, including implementation plans for the NERC Compliance Monitoring and Enforcement Program.
- **Compliance Program Administration and Oversight** – Responsible for: filing and maintaining technical feasibility exceptions; tracking critical cyber asset configuration data; addressing tactical compliance issues as they arise, participating in RSAW development; translating technical requirements into actionable tasks for operations personnel; performing annual reviews, updates and approvals of required documentation; contract administration and project management of vendors performing compliance-related scopes of work.
  - **Control System Expertise and Cyber Security** – Strong working knowledge of the infrastructure, software and cyber security capabilities of industrial process and distributed control systems, including those manufactured by Emerson, Honeywell, ABB, Allen Bradley, Siemens, GE Energy, Metso, Alstom, Toshiba and others. Forged strong working relationships with control system vendors in an effort to strengthen the cyber security posture of the company's control systems and establish best practices.

### PROFESSIONAL CERTIFICATIONS/TRAINING

- Certified Information Systems Auditor (CISA) awarded by ISACA
- Project Management Professional (PMP) awarded by the Project Management Institute (PMI)
- Physical Security Professional (PSP) awarded by ASIS International
- Certified Business Resilience Auditor (CBRA) awarded by BRCCI
- Candidate for: Certified Information Systems Security Professional (CISSP)
- Eagle Scout awarded by the Boy Scouts of America

Expertise in all Microsoft, Mac & other Common Corporate Applications, such as:

Word, Excel, Project, PowerPoint, Outlook, Visio, Adobe



**DJ MCCARTY**

Senior Security Consultant

**SUMMARY**

DJ McCarty is a seasoned business professional with experience in regulatory compliance, risk identification, and internal controls evaluations since 2014. He is able to develop policies and procedures companies need to demonstrate compliance with applicable regulations and laws. He is effective at performing compliance assessments, internal audits, investigations into possible violations, inherent risk assessments, internal controls evaluations, and compliance program development.

**SKILLS**

- Compliance Programs – developed, evaluated, and improved internal compliance programs, policies, and procedures
- Risk and Controls Frameworks – designed and implemented frameworks allowing companies to identify risks and develop controls to address risks
- Internal Controls – identified, evaluated, and improved
- Risk Assessments – identified and assesses company-specific and regulatory risks
- Regulatory Standards – experience in NERC CIP and O&P
- Compliance Gap Assessments – designed and performed compliance gap assessments
- Executive and business area communications – implemented and managed

**PROFESSIONAL EXPERIENCE****Archer Energy Solutions, LLC**      **2022-Present**

- **Senior Security Consultant.** Project work includes providing direct support to CIP clients in the areas of internal controls evaluations, risk identification, investigations into possible violations, and support of CIP compliance efforts for regulated utilities.

**Guidehouse, Inc.****2016-2022**

- **Associate Director**
  - Compliance Program Development and Implementation – collaborated with utilities of all sizes to understand reliability, compliance, and security needs and challenges. Developed processes, tools, and procedures to assist organizations in creating proactive compliance solutions to reduce compliance gaps and shortcomings. Developed training programs and delivered training to compliance and regulatory staff.
  - Risk and Controls Framework Design and Implementation – developed customized risk and controls frameworks to support utilities in the identification, assessment, and ongoing management of risks associated with compliance, reliability, and security. Evaluated and analyzed NERC requirements, change management, and program-level internal controls through a review of existing documents and interviews with compliance and regulatory staff.
  - Program Assessments – performed gap assessments to understand the current state of compliance programs and identified areas to improve the integration of NERC compliance. Assessed formal and informal internal compliance program practices and advised clients on organizational structure and operations improvements.
  - Mock Audits – assisted clients in audit preparation by facilitating and coordinating audit activities across the organization. Conducted mock audits and reviewed evidence to determine compliance with NERC requirements. Provided advice and guidance on the NERC CMEP to clarify processes for audits, spot checks, and mitigation

**Western Electricity Coordinating Council****2014-2016**

- **Enforcement Analyst.** Drafted WECC's Inherent Risk Assessment and Internal Controls Evaluations procedure documents and ensured WECC procedures were consistent with NERC's Reliability Assurance Initiative. Collaborated with Registered Entities in developing tailored improvements to foster a reliable bulk electric system. Advised Registered Entities on strategies to improve Mitigation Plans and Internal Compliance Programs. Improved WECC's settlement process to meet NERC requirements and streamline WECC's settlement efforts.

**Kristopher K. Greenwood, LC****2009-2011**

- **Attorney.** Consulted clients and provided guidance on legal matters. Interviewed witnesses, prepared and responded to interrogatories, and drafted motions in preparation for mediations and hearings. Presented findings and represented clients at mediations and hearings. Researched case law and code sections.

**EDUCATIONAL HISTORY**

Texas A&M University, Mays Business School, M.B.A. – 2011-2012

Pepperdine School of Law, J.D. – 2006-2009

University of Utah, B.A. Political Science – 2002-2005

# BOARD AGENDA REPORT

Date: 4/20/2023  
Staff: Chris Tuggle

---

**SUBJECT: SF6 Scale**

---

**RECOMMENDED ACTION:** Discussion and possible action to approve the purchase of an SF6 Gas Scale

---

**BACKGROUND AND/OR HISTORY:**

SF6 gas is utilized in several of our locations. This gas is classified as a greenhouse gas and requires strict processes in handling and refilling. In order to meet the requirements, a scale designed specifically for this purpose is required. The scale is used to measure the weight of our SF6 gas cylinders so we can properly report our usage to the State. In addition to the scale, we are purchasing a case so we can safely transport the scale from site to site. The purchase also includes and annual calibration within the first twelve months of use.

There are limited vendors available who are certified to offer SF6 equipment that meets State reporting requirements. This vendor offers a very comprehensive selection of SF6 equipment as well as the required annual calibration. Staff would like to create an account with this vendor so we can utilize their training and ongoing support.

**FISCAL IMPACT:** \$5,100

**ATTACHMENTS:** DILO Quote \$5,070.19

---

**Board Motion:**

**Motion by:** \_\_\_\_\_ **Second by:** \_\_\_\_\_

**VOTE:**

**OID:** DeBoer (Yes/No) Doornenbal (Yes/No) Orvis (Yes/No) Santos (Yes/No) Tobias (Yes/No)

**SSJID:** Holbrook (Yes/No) Kamper (Yes/No) Roos (Yes/No) Spyksma (Yes/No) Weststeyn (Yes/No)



# DILO Company, Inc.

11642 Pyramid Dr  
Odessa, FL 33556

# QUOTATION

Date of Issue	<b>Quotation #</b>	<b>Revision #</b>	Valid until:
3/2/2023	<b>Q-51056</b>	<b>REV01</b>	6/1/2023
<b>Customer Delivery Address &amp; Contact</b>			
Tri-Dam Project 31885 Old Strawberry Road Strawberry, CA 95375			
INCO Terms		FOB - Odessa, FL (origin)	
Ship Via:		Prepay & Add LTL	
Collect Account #		TBD	
<b>Estimated Lead Time</b>		<b>1-2 weeks</b>	

<b>Customer Billing Address &amp; Contact</b>	
Billing Information: Must be provided upon placement of order along with submission of customer form	
DILO Client Account #	TBD-upon placement of order
Payment Terms	Prepay

Responsible Regional Manager	Chris@dilo.com
Representing Agent	N/A

Item	Description	Qty	Price	Total
K091R65 + case	<p>SF6 Safety Cylinder Scale</p> <p>Includes: - Calibration Certificate - Printed Manual *English - Transport Case</p> <p>*LTL shipping is required</p> <p>Prepaid maintenance cycle for K091 service</p> <p>FIRST CYCLE services *valid for use within 12 months of initial delivery. (30) day grace period if not used after 12 months after initial delivery</p> <p>Customer contact: • Name:                      • Phone:                      • E-mail:</p> <p>Note: unit must be shipped to/from DILO. Pricing does not include shipping charges.</p>	1	4,244.25	<b>4,244.25</b>

Client full name	Chris Tuggle
Client phone	209-648-6230
Client email	ctuggle@tridamproject.com



# DILO Company, Inc.

11642 Pyramid Dr  
Odessa, FL 33556

# QUOTATION

Date of Issue	Quotation #	Revision #	Valid until:
3/2/2023	Q-51056	REV01	6/1/2023
<b>Customer Delivery Address &amp; Contact</b>			
Tri-Dam Project 31885 Old Strawberry Road Strawberry, CA 95375			
INCO Terms		FOB - Odessa, FL (origin)	
Ship Via:		Prepay & Add LTL	
Collect Account #		TBD	
<b>Estimated Lead Time</b>		<b>1-2 weeks</b>	

Customer Billing Address & Contact	
Billing Information: Must be provided upon placement of order along with submission of customer form	
DILO Client Account #	TBD-upon placement of order
Payment Terms	Prepay

Responsible Regional Manager	Chris@dilo.com
Representing Agent	N/A

Item	Description	Qty	Price	Total
S&H-Outgoing (LTL)	Shipping and Handling (LTL) <ul style="list-style-type: none"> <li>Common Carrier listed above</li> <li>Declared value: \$4,244.25</li> <li>Estimated Weights and Dims: 48 L x 40 W x H 18 / Weight 100 lbs.</li> <li>Carrier will have offloading capability: YES</li> </ul> Note: <ul style="list-style-type: none"> <li>All shipping charges are Estimated and Subject to change upon shipment date.</li> <li>Pricing does not include expedited handling fees.</li> <li>Actual street address including city, state/province, zip code must be provided. DILO is not responsible for delays as a result of incorrect delivery/site address.</li> </ul> ATTENTION: Packing NOT suitable for storage purposes. Please unpack immediately after receipt. Device must be stored clean and dry. DELIVERY: Please note, special provisions may be required for off-loading. Customer is responsible to offload and receive equipment and/or materials received from DILO Company Inc.		518.23	<b>518.23</b>

Client full name	Chris Tuggle
Client phone	209-648-6230
Client email	ctuggle@tridamproject.com

<b>Sales Tax (7.25%)</b>	USD 307.71
<b>Total</b>	<b>USD 5,070.19</b>

**Signature:** \_\_\_\_\_

Signing this quote and submitting a PO accepts DILO's Terms & Conditions at <https://us.dilo.com/contact-us/terms-and-conditions/> as well as any additional terms. DILO's terms supersede any terms submitted.  
 DILO also accepts payment via Check, Credit Card, ACH, Wire-Transfer, or Secure Payment Portal.  
 \*\*DILO quote and revision # must be referenced on the customer purchase order\*\*

GENERAL MANAGER BOARD REPORT  
Summer Nicotero  
April 20, 2023

1. FERC has notified us that we have been selected for a Cybersecurity audit. The fieldwork is scheduled to take place at the end of August. The team will be compiling the requested documentation for submission to FERC by the end of July. I will be working closely with Michael Ballinger and Michael O'Leary in the coming months as we prepare for the audit.
2. FEMA is coming on-site as I write this to do a site visit and assessment of our rock fall. I hope to have more information to report at the meeting.
3. I am continuing the work on our insurance renewals. Chris and his team have gathered the requested documents relating to our generation assets and I am working on the administrative reporting. As previously reported, it is expected that our renewal will come at an increased cost, with very preliminary estimates at 22% over prior year. The majority of the increases are related to liability and worker's compensation policies.
4. Our Finance Manager, Vera, started at the beginning of April. She has worked with Sharon and I as we submit the audit documents to our Auditor. The field audit will begin on May 1 and should be completed within the week. This has been an intense training for Vera and we are happy she has joined the team during such a critical period.
5. Maintenance and Operations flew out to Donnells to make necessary repairs and assess the storm damage last week. The road had some tree-falls, which we anticipate we can clear ourselves. There were some slide areas that we will have to assess further to determine the level of damage and prepare a plan to repair. While meeting with FEMA today I plan to discuss this as something we may need to add to our damage claim.
6. Our Maintenance Lead, Rich Ennis, has accepted a position with NCPA. We will miss Rich as he was a solid leader who was willing to take on any challenge, complete any task, and support Tri-Dam in all his efforts. We will begin the internal recruiting process, according to our MOU.

OPERATIONS AND MAINTENANCE MANAGER BOARD REPORT

Chris Tuggle  
April 20, 2023

**OPERATIONS:**

**Reservoir Data (A/F):**

<b>FACILITY</b>	<b>STORAGE</b>	<b>MONTH CHANGE</b>
Donnells	12,944	2,659
Beardsley	78,423	4,227
Tulloch	56,420	(1,238)
New Melones	1,393,412	295,887

**Outages:**

<b>Plant</b>	<b>Dates</b>	<b>Duration</b>	<b>Cause</b>
SPH	March 1	19:00Min	Requested shut down from SVP
BPH	March 1	26:00Min	Requested shut down form SVP
DPH	March 31	3:39 Hr	PGE transmission line fault
BPH	March 31	3:47 Hr	PGE transmission line fault
SPH	March 31	1:48 Hr	PGE transmission line fault

**Operations Report:**

**New Melones Inflows:**

Total inflows for water year 22/23 as of March 31: 921,102 A/F.

**District Usage:**

Total District usage for the water year 22/23 as of March 31: 34,950 A/F.

**Precipitation:**

Total precipitation for the month of March: 15.48 inches.

**Other Activities:**

1. Conducted the Beardsley penstock tunnel inspection.
2. Goodwin site visit for the tunnel project.
3. Daily checks all powerhouse.
4. Hired two Powerplant Operators.
5. Calibrated stilling wells and prepared division for irrigation.
6. Started irrigation season.

# OPERATIONS AND MAINTENANCE MANAGER BOARD REPORT

Chris Tuggle  
April 20, 2023

## **MAINTENANCE:**

### **Donnell:**

1. Equipment in service.
2. March 31, PG&E transmission line fault tripped DPH, BPH and SPH. The desk operator called in two operators to restore the powerhouses.

### **Beardsley:**

1. Equipment in service.
2. On April 6, we will remove the Beardsley Spillway Bridge to protect it from expected high runoffs.
3. On March 1 Beardsley governor controls were not responding. The desk operator called in an operator and technician to troubleshoot the problem.

### **Sandbar:**

1. Equipment in service.
2. Due to all the rain and snow, a portion of Sandbar Road, just before the PG&E fish screen, is sliding down the hillside. PG&E Engineers are assessing the road.

### **Tulloch:**

1. Equipment in service.

### **Goodwin:**

1. Equipment in service.

### **Division:**

1. Replaced the Division microwave radio battery bank.

## **Future Projects:**

1. Peeled Onion rockslide.
2. Beardsley gate 1 trunnion pin.
3. Division communications tower.
4. Donnells E-Gen replacement.
5. Goodwin E-Gen replacement.
6. Donnells solar power.



**BEARDSLEY PRECIPITATION**

YEAR	JUL	AUG	SEPT	OCT	NOV	DEC	JAN	FEB	MAR	APR	MAY	JUNE	TOTAL
1958-59	0.00	0.00	0.00	0.00	0.00	0.00	0.00	7.40	1.39	1.40	1.04	0.00	11.23
1959-60	0.00	0.03	3.09	0.00	0.00	1.92	5.74	8.38	4.68	2.45	0.35	0.00	26.64
1960-61	0.05	0.00	0.44	0.63	5.33	2.43	1.60	3.04	4.96	1.49	1.84	0.29	22.10
1961-62	0.21	1.12	0.77	0.70	3.39	2.98	2.04	15.32	6.13	1.12	1.04	0.02	34.84
1962-63	0.30	0.16	0.35	2.98	1.05	2.66	5.91	8.37	6.08	8.24	3.70	0.74	40.54
1963-64	0.00	0.44	0.59	2.63	7.81	0.81	5.84	0.21	3.02	2.01	2.44	1.64	27.44
1964-65	0.00	0.00	0.34	2.08	7.40	17.93	5.90	1.34	2.44	5.27	0.32	0.29	43.31
1965-66	0.00	1.47	0.60	0.47	12.38	4.59	1.68	2.33	1.00	2.39	0.43	0.10	27.44
1966-67	0.13	0.00	0.28	0.00	7.55	8.48	8.77	0.67	10.02	10.25	2.04	1.05	49.24
1967-68	0.00	0.39	0.90	0.54	2.47	3.35	4.94	4.81	3.48	0.73	1.44	0.02	23.07
1968-69	0.10	0.65	0.00	2.12	6.22	8.28	19.45	8.35	1.88	3.39	0.21	0.39	51.04
1969-70	0.00	0.00	0.55	3.41	2.98	6.46	17.06	3.11	3.43	2.50	0.00	3.17	42.67
1970-71	0.00	0.00	0.00	0.91	10.71	8.44	2.83	1.16	4.87	1.49	1.80	0.77	32.98
1971-72	0.00	0.02	0.29	1.22	6.22	10.31	2.39	2.78	1.01	4.03	0.10	1.62	29.99
1972-73	0.00	0.58	0.17	1.85	6.27	5.57	12.08	12.06	5.31	1.11	0.72	0.74	46.46
1973-74	0.05	0.18	0.07	3.65	9.88	9.10	5.08	1.84	8.18	5.15	0.02	0.07	43.27
1974-75	2.57	0.10	0.00	2.82	2.38	4.95	4.25	10.16	9.90	5.41	0.84	0.63	44.01
1975-76	0.03	2.02	0.15	6.75	2.04	0.74	0.49	3.03	2.66	2.42	0.91	0.05	21.29
1976-77	0.10	2.43	1.00	0.93	1.54	0.24	2.50	2.68	2.06	0.25	4.65	0.38	18.76 RECORD LOW
1977-78	0.00	0.00	0.58	0.24	4.76	9.72	10.85	8.31	8.67	7.97	0.19	0.23	51.52
1978-79	0.08	0.00	3.98	0.07	3.17	4.43	8.45	7.60	6.05	1.86	2.88	0.02	38.59
1979-80	0.17	0.03	0.00	4.66	4.63	5.22	14.62	13.03	3.61	3.09	4.33	0.77	54.16
1980-81	0.43	0.02	0.03	0.71	0.58	3.04	8.05	2.69	6.26	1.67	1.42	0.00	24.90
1981-82	0.06	0.00	0.15	5.27	8.76	8.39	6.08	8.08	11.23	8.19	0.12	1.34	57.67
1982-83	0.03	0.02	4.02	8.78	11.30	7.32	10.83	14.34	12.86	6.29	0.74	0.12	76.65 RECORD HIGH
1983-84	0.01	0.09	3.86	1.35	16.44	12.75	0.27	5.51	3.56	2.70	0.84	1.31	48.69
1984-85	0.00	0.05	0.73	3.97	10.28	2.58	1.52	3.13	5.84	0.86	0.07	0.28	29.31
1985-86	0.30	0.12	2.64	3.09	7.71	4.52	4.70	21.98	8.43	2.37	1.58	0.00	57.44
1986-87	0.02	0.00	2.18	0.00	0.49	0.73	3.42	5.89	5.21	0.79	1.63	0.15	20.51
1987-88	0.00	0.00	0.00	2.19	2.22	5.79	5.42	0.88	0.73	3.15	1.66	0.79	22.83
1988-89	0.00	0.00	0.05	0.07	6.96	4.29	1.45	2.73	10.08	1.41	0.74	0.02	27.80
1989-90	0.00	0.33	3.28	4.30	3.02	0.00	4.75	3.40	2.75	1.66	3.46	0.21	27.16
1990-91	0.00	0.11	0.59	0.41	1.62	1.30	0.40	1.79	16.08	1.74	2.54	1.54	28.12
1991-92	0.17	0.10	0.32	5.54	2.32	3.10	1.97	7.68	4.58	0.45	0.45	1.66	28.34
1992-93	3.26	0.35	0.00	3.05	0.44	9.61	12.19	8.74	6.29	2.07	1.24	2.43	49.67
1993-94	0.00	0.00	0.00	1.25	2.11	1.97	2.93	7.08	0.86	3.71	2.22	0.00	22.13
1994-95	0.00	0.00	0.77	2.82	7.92	3.68	18.32	1.14	18.76	6.98	6.72	1.02	68.13
1995-96	0.05	0.00	0.00	0.00	0.35	9.13	10.32	11.17	6.81	3.94	5.51	1.24	48.52
1996-97	0.05	0.01	0.23	2.55	7.14	16.19	18.16	0.80	0.53	0.82	0.51	1.24	48.23
1997-98	0.17	0.00	0.33	1.39	4.99	3.70	12.86	16.30	6.69	4.94	6.46	1.35	59.18
1998-99	0.00	0.00	2.84	0.49	5.12	3.13	8.93	9.71	2.63	3.03	1.28	1.03	38.19
1999-00	0.00	0.13	0.18	1.05	3.51	0.51	11.68	14.13	2.58	3.70	2.72	1.06	41.25
2000-01	0.00	0.07	0.96	3.17	1.01	1.59	4.69	4.70	3.08	5.39	0.00	0.07	24.73
2001-02	0.02	0.00	0.60	1.17	6.97	9.75	2.56	2.13	6.88	2.29	2.02	0.00	34.39
2002-03	0.00	0.00	0.09	0.00	7.42	11.17	1.12	3.50	3.81	9.36	2.69	0.00	39.16
2003-04	0.09	1.32	0.06	0.00	2.88	9.97	2.79	8.52	1.07	0.17	0.55	0.02	27.44
2004-05	0.02	0.00	0.19	7.66	2.93	6.67	10.52	6.95	9.35	3.35	5.76	0.80	54.20
2005-06	0.00	0.11	0.71	1.70	3.34	17.72	7.75	5.26	10.14	10.55	1.97	0.10	59.35
2006-07	0.08	0.00	0.01	1.53	3.56	5.25	2.08	8.70	1.30	2.61	1.33	0.10	26.55
2007-08	0.01	0.17	0.34	1.02	0.95	5.01	10.15	6.69	0.87	0.26	2.85	0.00	28.32
2008-09	0.00	0.00	0.00	1.65	6.17	5.08	5.88	6.98	6.78	1.97	3.37	0.79	38.67
2009-10	0.00	0.10	0.00	4.37	1.31	5.89	7.97	5.86	4.92	6.66	3.65	0.06	40.79
2010-11	0.00	0.00	0.00	8.67	7.15	14.21	2.15	5.76	15.22	1.94	2.94	3.21	61.25
2011-12	0.00	0.00	1.56	3.13	1.77	0.00	6.25	1.62	5.96	4.76	0.37	0.92	26.34
2012-13	0.00	0.00	0.00	1.27	5.78	12.56	0.64	0.93	3.26	1.11	1.48	0.80	27.83
2013-14	0.00	0.00	0.72	0.56	1.80	1.22	1.59	9.23	6.17	3.43	0.98	0.05	25.75
2014-15	0.52	0.03	1.03	0.15	3.72	7.25	0.13	4.49	0.43	3.08	2.75	0.80	24.38
2015-16	0.39	0.00	0.11	2.26	5.36	9.74	9.53	1.74	9.19	3.13	1.82	0.34	43.61
2016-17	0.00	0.00	0.00	7.26	3.19	8.30	22.25	20.47	5.49	8.06	0.59	0.46	76.07
2017-18	0.00	0.09	1.44	0.50	7.34	0.42	5.20	0.76	14.50	3.70	1.02	0.00	34.97
2018-19	0.00	0.00	0.00	1.92	8.21	3.07	9.84	15.37	8.97	2.07	7.43	0.46	57.34
2019-20	0.00	0.00	0.63	0.00	1.39	10.58	2.09	0.08	7.50	3.87	3.09	0.33	29.56
2020-21	0.00	0.23	0.10	0.00	2.38	3.40	7.28	2.44	2.83	1.31	0.18	0.00	20.15
2021-22	0.09	0.00	0.18	7.51	0.95	13.37	0.04	0.36	0.96	4.14	0.39	0.31	28.30
2022-23	<b>0.00</b>	<b>0.29</b>	<b>2.27</b>	<b>0.02</b>	<b>3.83</b>	<b>12.65</b>	<b>21.85</b>	<b>5.43</b>	<b>15.48</b>	<b>0.17</b>	<b>0.00</b>	<b>0.00</b>	<b>61.99</b> Current Year
Average	0.15	0.21	0.74	2.23	4.70	6.18	6.74	6.15	5.88	3.38	1.87	0.62	38.83
2021-22 +/-	(0.15)	0.08	1.53	(2.21)	(0.87)	6.47	15.11	(0.72)	9.60	(3.21)	(1.87)	(0.62)	23.16

ANNUAL AVERAGE

**38.83**

INCHES +/- ANNUAL AVERAGE

23.16

Updated as of 13-Apr-23

PERCENT OF ANNUAL AVERAGE

160%

April 4, 2023	DRAINAGE AREA SQ. MILES	DRAINAGE AREA ACRES	WATER IN FEET	WATER CONTENT AC-FT	RECOVERY AT 75%	RECOVERY AT 70%	RECOVERY AT 65%	RECOVERY AT 60%	RECOVERY AT 55%	RECOVERY AT 50%
NO. FORK NEAR AVERY	163	104,320	8.167	851,981	638,986	596,387	553,788	511,189	468,590	425,991
SO. FORK	67	42,880	8.167	350,201	262,651	245,141	227,631	210,121	192,611	175,100
MIDDLE FORK AT DONNELLS	230	147,200	8.167	1,202,182	901,637	841,528	781,419	721,309	661,200	601,091
MIDDLE FORK AT BEARDSLEY	309	197,760	8.167	1,615,106	1,211,329	1,130,574	1,049,819	969,064	888,308	807,553
TOTAL		344,960		2,817,288	2,112,966	1,972,102	1,831,237	1,690,373	1,549,509	1,408,644
MELONES DRAINAGE AREA	904	578,560					MELONES INFLOW TO DATE	921,102	April 4, 2023	
							PROJECTED SNOW RUNOFF (65% RECOVERY)	1,831,237	Projected April to July runoff	
STORAGE ON APRIL 1, 2023	MAX STOR	DIFFERNCE					UPSTREAM STORAGE RETENTION	50,000		
NEW MELONES	1,393,412	2,419,523	(1,026,111)				PROJECTED MELONES INFLOW	2,702,339		
DONNELLS	12,944	64,325	(51,381)							
BEARDSLEY	78,423	97,802	(19,379)							
NEW SPICER	51,751	189,000	(137,249)							
TOTAL	143,118	351,127	(208,009)							

## REGULATORY AFFAIRS BOARD REPORT

Susan Larson

April 20, 2023

### FERC Compliance

- Hells Half Acre Road. Following formal submittal, the USFS has indicated that engineering and design and cultural resources staff have no comments. Awaiting confirmation from SHPO that the final cultural mitigation is fully approved, following approval by the USFS. The goal will be to have the project fully approved so that the project can be circulated for bid in early 2023, for construction in the summer/early fall of 2023.
- The DSSMRs (Dam Safety Surveillance and Monitoring Reports) were filed with FERC on time, and a copy of all reports provided to DSOD as well.
- Tulloch 5 Year invasive species update. The aquatic invasive species mapping was updated, and will be compiled to go along with the report. As soon as the mapping is updated, the report and map will be circulated to agencies for a 30-day review as required by license requirements.
- Tulloch Day Use Site. Staff is working with Project Engineer Joe Murphy and KWE to finalize punch list items. Several are weather dependent; thus, it is projected that these will be done during the weeks of April 17<sup>th</sup> and April 24<sup>th</sup>, 2023, such that final inspections can be requested by County departments immediately thereafter.
- Tulloch Spillway Road. Following the Board meeting in March, Tri-Dam and Provost & Pritchard participated in a conference call with the Bureau of Reclamation, to discuss maximum flows scenarios for releases from New Melones so that design parameters can be finalized. The call was extremely helpful, and we obtained important data from the Director of Control Room Operations. Provost & Pritchard is working on the proposal for the next phases, and staff intends to bring those forward to the Board at the May 2023 meeting.
- Cybersecurity Audit. Initial research and support for identification of program updates/options to prepare for the FERC audit to be performed in August 2023. General Manager Nicotero is serving as agency lead.

### Permit and Other Assignments

Work on permits, site reviews and compliance questions for various properties at Tulloch. Respond to daily inquiries from the public. Permits, inspections and file documentation.

- Tulloch compliance matters, as required.
- Working on pending litigation matters, as required.
- Interviews for the Natural Resources intern are scheduled for April 18, 2023.



## Tri-Dam Project Generation & Revenue Report 2023

	<b>Donnells</b>			<b>Beardsley</b>			<b>Tulloch</b>			<b>Project Total</b>			
	Average Generation (1958-2018)	2023 Net Generation (kWh)	Avoided Generation (kWh)	2023 Energy Revenue	Average Generation (1958-2018)	2023 Net Generation (kWh)	2023 Energy Revenue	Average Generation (1958-2018)	2023 Net Generation (kWh)	2023 Energy Revenue	Average Generation (1958-2018)	2023 Net Generation (kWh)	2023 Energy Revenue
JAN	17,389,989	50,302,120	-	\$4,024,170	3,150,048	8,075,579	\$646,046	4,271,885	5,667,702	\$453,416	24,811,922	64,045,400	\$5,123,632
FEB	17,229,608	26,972,429	-	\$2,157,794	2,927,753	7,428,960	\$594,317	5,024,913	1,668,267	\$133,461	25,182,274	36,069,657	\$2,885,573
MAR	23,070,659	34,546,717	-	\$2,763,737	3,584,274	8,181,638	\$654,531	7,580,691	9,910,971	\$792,878	34,235,623	52,639,326	\$4,211,146
APR	31,686,865		-	\$0	4,717,464		\$0	10,811,027		\$0	47,215,356		\$0
MAY	41,216,149		-	\$0	5,799,593		\$0	12,131,040		\$0	59,146,782		\$0
JUN	42,555,036		-	\$0	6,336,073		\$0	12,084,818		\$0	60,975,928		\$0
JUL	36,444,466		-	\$0	6,629,514		\$0	12,609,174		\$0	55,683,154		\$0
AUG	27,568,740		-	\$0	6,269,748		\$0	11,868,293		\$0	45,706,781		\$0
SEP	20,111,167		-	\$0	5,223,523		\$0	8,577,620		\$0	33,912,310		\$0
OCT	12,743,535		-	\$0	3,752,220		\$0	4,664,124		\$0	21,159,879		\$0
NOV	12,042,987		-	\$0	2,794,775		\$0	2,487,256		\$0	17,325,019		\$0
DEC	14,354,891		-	\$0	3,713,920		\$0	3,288,702		\$0	21,357,513		\$0
<b>Total</b>	<b>296,414,092</b>	<b>111,821,266</b>	<b>-</b>	<b>\$8,945,701</b>	<b>54,898,907</b>	<b>23,686,176</b>	<b>\$1,894,894</b>	<b>95,399,542</b>	<b>17,246,940</b>	<b>\$1,379,755</b>	<b>446,712,540</b>	<b>152,754,382</b>	<b>\$12,220,351</b>

Note: Price per MWh is \$80.00

### Tri-Dam Power Authority - Sand Bar

	Average Generation (1958-2018)	2023 Net Generation (kWh)	2023 Energy Revenue	PG&E Coordination Payment	Total Revenue
JAN	4,663,654	11,625,894	\$930,072	\$0	\$930,072
FEB	3,946,606	10,595,708	\$847,657	\$0	\$847,657
MAR	5,290,014	11,889,429	\$951,154	\$0	\$951,154
APR	6,873,822		\$0	\$0	\$0
MAY	8,065,189		\$0	\$0	\$0
JUN	8,750,023		\$0	\$0	\$0
JUL	9,133,101		\$0	\$0	\$0
AUG	8,560,581		\$0	\$0	\$0
SEP	6,928,285		\$0	\$0	\$0
OCT	4,898,944		\$0	\$0	\$0
NOV	2,947,604		\$0	\$0	\$0
DEC	5,554,123		\$0	\$0	\$0
<b>Total</b>	<b>75,611,948</b>	<b>34,111,032</b>	<b>\$2,728,883</b>	<b>\$0</b>	<b>\$2,728,883</b>

## Tri-Dam Project Generation Revenue

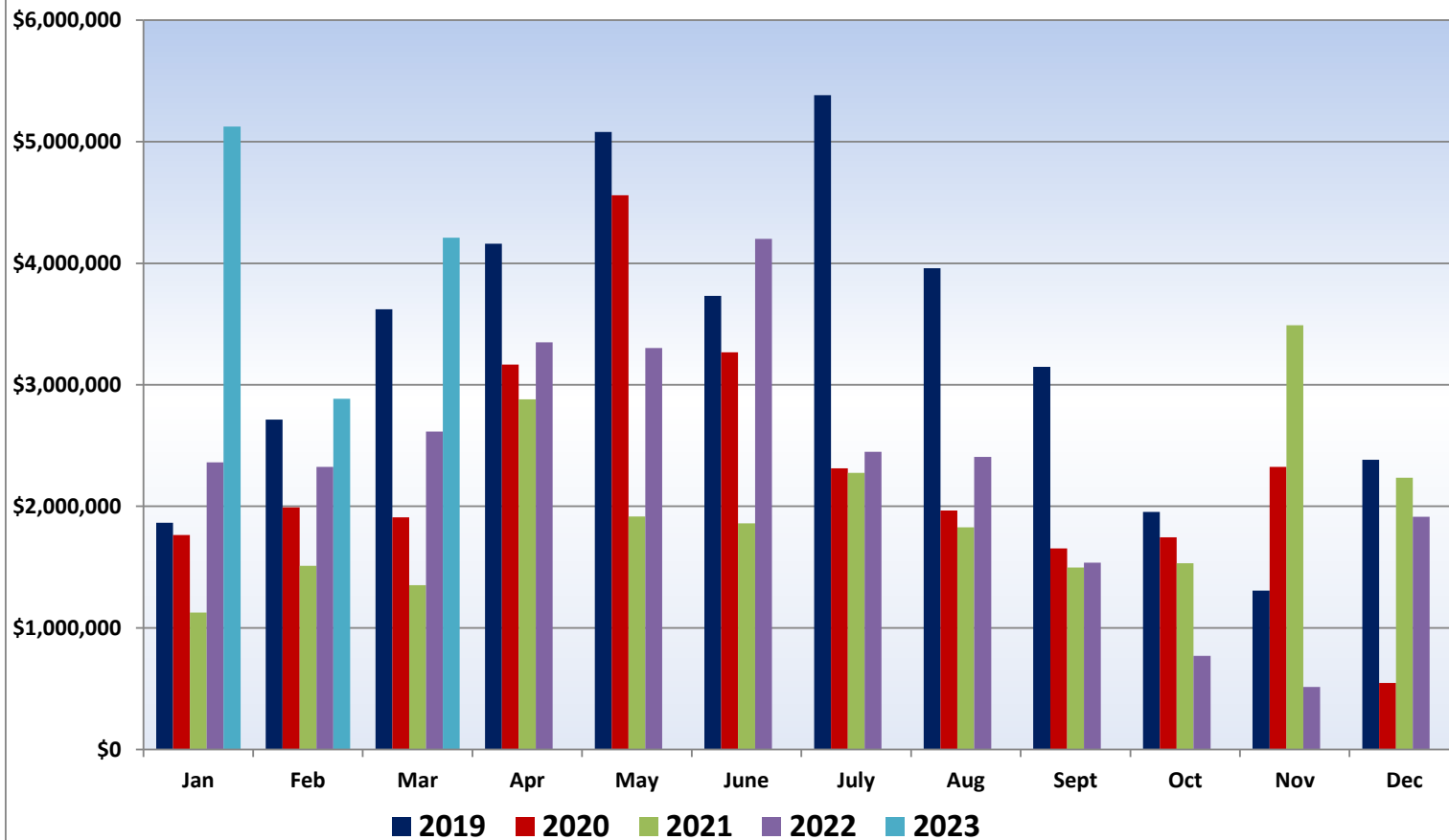

## Tri-Dam Project Storage AF - Donnells & Beardsley

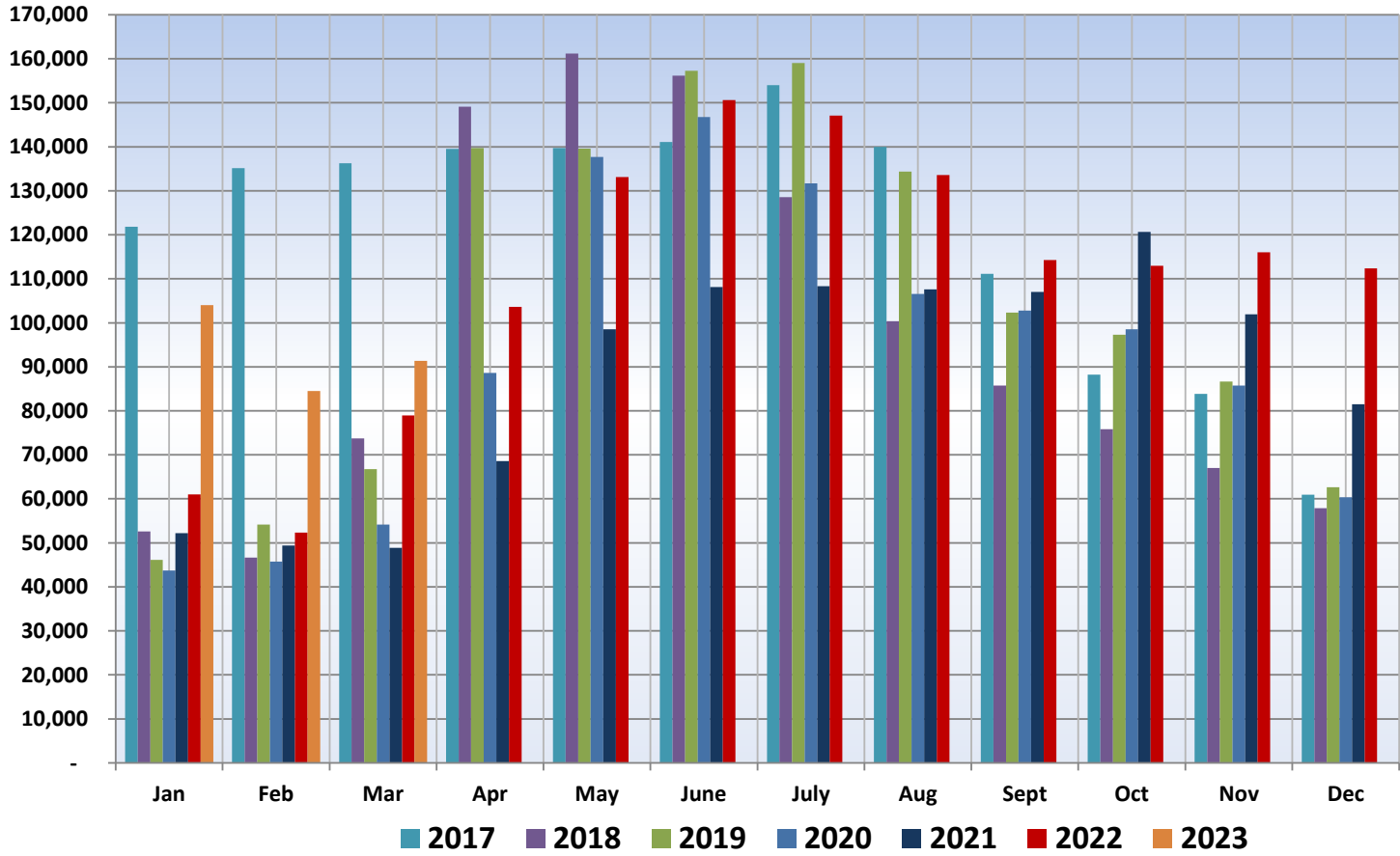

# Tri-Dam Project Total Generation - MWh

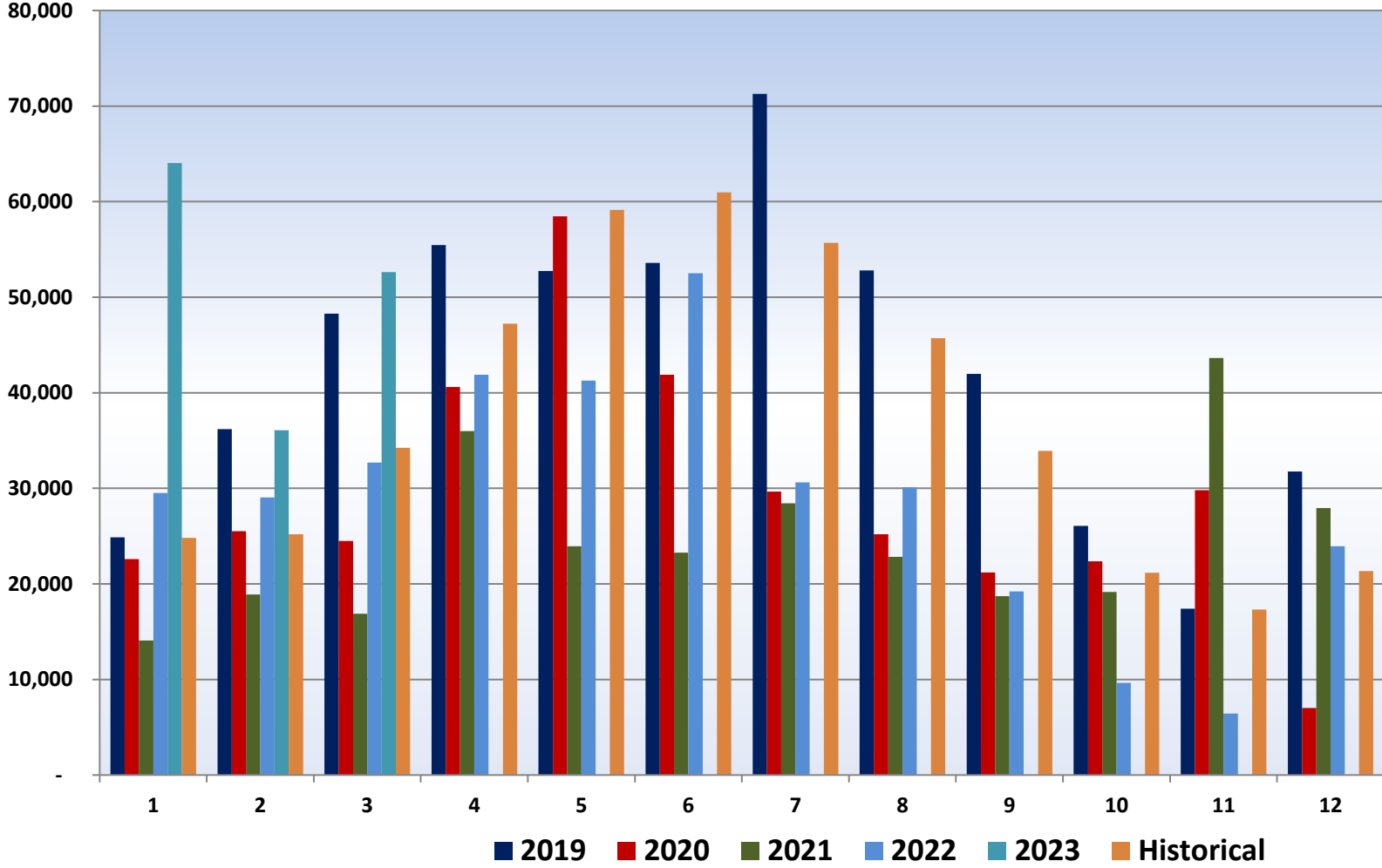



## WESTERN PRICE SURVEY

### [7] Western Energy Prices Move Higher

Western energy prices generally continued to rise despite moderate demand and below-normal temperatures across California.

Most Western natural gas hubs gained between 7 and 38 cents in the abbreviated March 30 to April 5 trading period. They were led by Sumas, which added 38 cents to reach \$6.16/MMBtu.

SoCal Border and El Paso-San Juan Basin natural gas moved lower by 33 cents and \$1.96, respectively, to \$5.40/MMBtu and \$2.90/MMBtu.

By the end of April 5 trading, SoCal CityGate gas posted the highest price at \$8.65/MMBtu. Western prices were generally above the \$5 mark (see table).

Markets were closed April 7 in observance of Good Friday.

Average temperatures throughout the western U.S. were 4 degrees to 8 degrees below normal during the U.S. Energy Information Administration Wednesday-to-Wednesday report week.

Total natural gas use across all sectors—in both the EIA West and Rocky Mountain regions—eroded by 0.7 Bcf per day, or 5 percent, between March 29 and April 5, the EIA said. The greatest drop was in the residential and commercial sector, which dipped by 0.6 Bcf, or 9 percent.

California Independent System Operator grid demand softened by roughly 420 MW week over week. Demand reached 27,443 MW April 3, which was the week's high. Western Power Pool demand peaked the following day at 68,515 MW.

No natural gas was withdrawn from Pacific region storage between March 24 and March 31, according to the EIA. Regional storage remains at 71 Bcf, which is 55.5 percent less than a year ago and 56.8 percent less than the five-year average.

A total of 896 MMcf was withdrawn from Aliso Canyon storage on the gas days between March 30 and April 5, according to ENVOY.

Power prices—both peak and off-peak—gained value in March 30 to April 6 trading. California-Oregon Border daytime power gained the most value, surging by \$68 to \$137.50/MWh.

Likewise, Western off-peak power prices added value across the board in trading. Mid-Columbia nighttime power gained the most value, up \$36.65 to \$100.85/MWh.

**In March, the average high peak price** at Henry Hub was \$2.68/MMBtu, \$2.81 less than in 2022 (see "Price Trends," next page).

Western natural gas hub prices jumped by as much as \$7.44 year over year, led by PG&E CityGate gas, which posted a high price of \$12.37/MMBtu.

Average Western peak power prices for March were generally higher compared with the year prior. COB gained the most value year over year, up \$109.25 to \$153.25/MWh. Mid-C daytime power moved down \$27.15 to \$35.85/MWh, which was the lowest regional price. —*Linda Dailey Paulson*

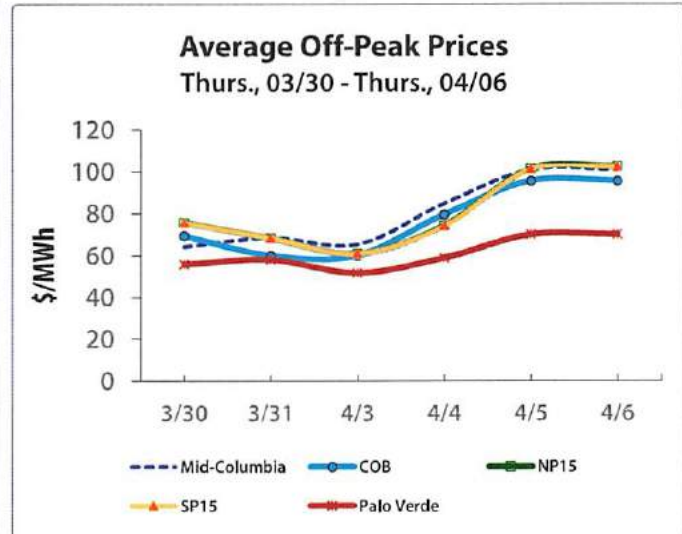
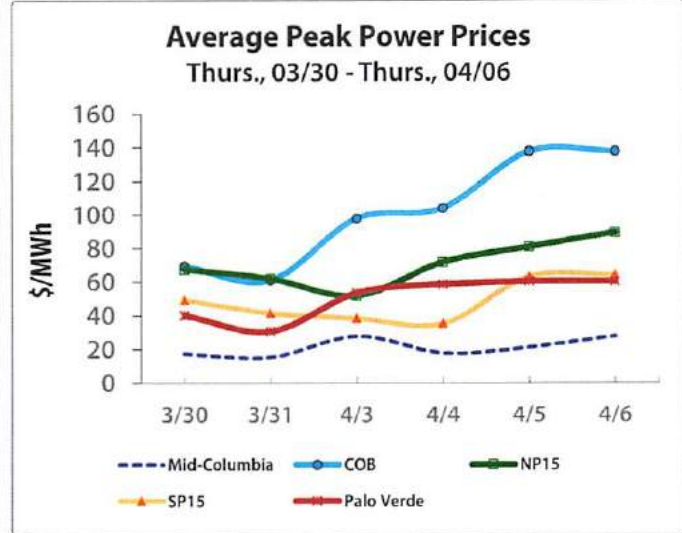

	Thurs. 03/30	Tues. 04/04	Wed. 04/05
Henry Hub	1.96	2.13	2.18
Sumas	5.78	6.07	6.16
Alberta	2.54	2.53	2.61
Malin	6.11	6.23	6.25
Opal/Kern	5.96	6.10	6.15
Stanfield	6.07	6.13	6.19
PG&E CityGate	7.09	7.32	7.31
SoCal Border	5.73	4.49	5.40
SoCal CityGate	8.37	8.84	8.65
EP-Permian	1.35	1.54	1.72
EP-San Juan	4.86	3.15	2.90

*Power/gas prices courtesy Enerfax*





# CURRENT RESERVOIR CONDITIONS

## CALIFORNIA MAJOR WATER SUPPLY RESERVOIRS

Midnight - April 12, 2023

### CURRENT CONDITIONS

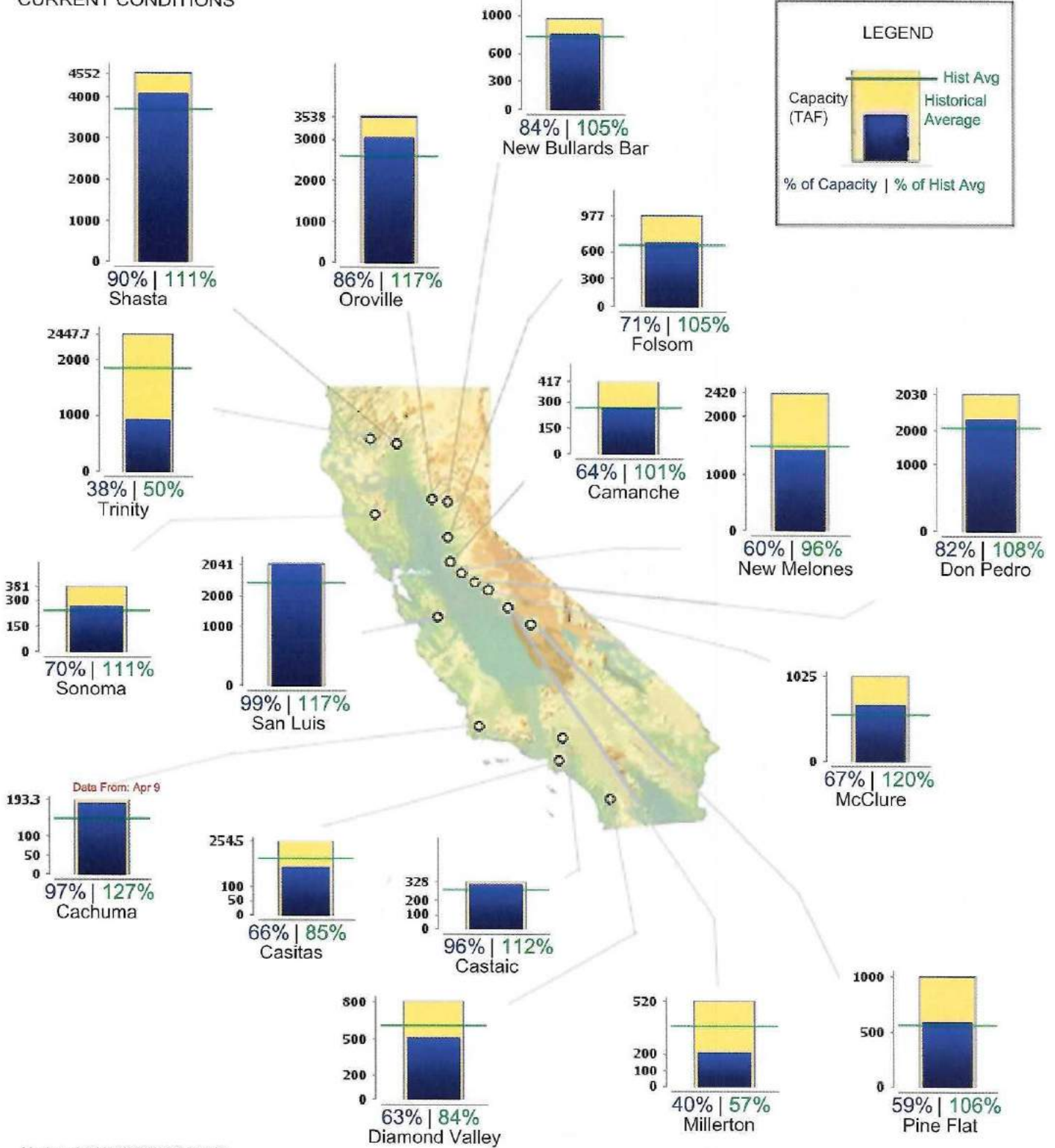



## Client Memo

### *Review of the 2022 Pacific Coast Salmon Fisheries*

April 7, 2023

The Pacific Fishery Management Council (PFMC) publishes a series of reports each spring detailing harvest and escapement results for the salmon fishery along the West Coast during the previous year. The reports provide data to assess the status of managed stocks in the ocean, accuracy of preseason predictions, impacts of prior management decisions, and economic benefits from the previous season. The estimates of salmon that returned to the Central Valley in 2022 and the forecasts for 2023 both paint a bleak picture for salmon populations in California. Returns to Central Valley Rivers in 2022 were among the lowest on record, and due to low forecasted abundance this year, the California commercial and recreational salmon fishery will be closed for the first time since 2008-2009. This memo describes important information from the PFMC reports, with key points summarized below.

#### **Key Findings from the 2022 Salmon Fishery**

- PFMC predicted that nearly 400,000 Sacramento River fall-run Chinook (SRFC) were available in the ocean, and that based on fishing regulations and quotas that nearly 200,000 would escape to the spawning grounds.
- Abundance was severely overestimated in 2022, with the actual abundance estimated at only about 250,000 salmon as compared to the 400,000 predicted.
- This inaccurate preseason forecast led to 75% of SRFC being harvested in 2022, the highest rate since 2004.
- Inaccurate forecasts continue to hamper effective management, and abundance has been overestimated in more than 75% of years since 2005.
- As a result of lower abundance and the high harvest rate, SRFC escapement was only 61,850, the third lowest over more than 50 years, and only about half of the annual target of 122,000 hatchery and natural area spawners.
- Escapement to the San Joaquin River (SJR) basin was 40% higher than it was the previous year, but still 25% less than the five-year average. Escapement to the SJR basin comprised exactly 14% of the Central Valley total (historically it was <10%).
- Over the last four years, between 79-85% of the Pacific Coast commercial Chinook landings by weight were landed in the three southern-most California port areas – Fort Bragg, San Francisco, and Monterey. Prior to 2019, the average annual share landed in the three southern-most California port areas was approximately 40%.
- Landings revenues totaled \$17.1 million, which was less than last year but 21% more than the previous five-year average. Overall, the value of the fishery is well below the 1979-1990 inflation-adjusted average of \$40.5 million.
- It is estimated that SRFC abundance in the ocean in 2023 only about 170,000. As a result, PFMC has decided to close the California commercial and recreational salmon fishery this year.

fishbio.com

**Oakdale Office**  
1617 S. Yosemite Ave.  
Oakdale, CA 95361  
PH: (209) 847-6300

**Chico Office**  
180 East 4th Street, Suite 160  
Chico, CA 95928  
PH: (530) 892-9686

**Santa Cruz Office**  
519 Seabright Avenue, Suite 208  
Santa Cruz, CA 95062  
PH: (831) 600-8762

**Laos Office**  
Ban Phonesavanh Nuea  
Unit 18, Dongpaina Road  
Vientiane Capital, Lao PDR  
PH: +(856) 20-2999-3276

## Accuracy of the 2022 Predictions

Sacramento River fall-run Chinook (SRFC) are the primary stock of interest in California, as this population contributes the majority of fish caught in the ocean fishery. The metric used to represent their abundance for management purposes is called the Sacramento Index (SI), which is the number of adult fish (ages 3–5) projected to be available in the ocean that will either be harvested or will escape to spawn in natural areas and hatcheries in the Sacramento River Basin. The SI is notoriously difficult to forecast as it depends on the escapement of jacks (early maturing males) the previous year, with the assumption that jacks make up a consistent percentage of the overall adult abundance each year. However, this has not always been the case in recent years and as a result, PFMC has overestimated the SI in 14 of the last 18 years despite changes to the forecasting methods that were intended to improve accuracy (Figure 1).

Inaccurate forecasts of SRFC abundance are a continuing concern for management of the Central Valley population. Overestimation of the population can lead to reduced escapement and low numbers of fish available for in-river recreational fishing, while underestimation can impose unnecessary restrictions on the commercial fishery. Improvements in tagging and escapement monitoring programs could eventually allow for more accurate preseason predictions, but no such improvements are currently planned.

The preseason forecast in 2022 continued the trend of overestimating the actual population. The preseason forecast for 2022 was an SI of 396,458 fish, with a total projected spawning escapement (hatchery and natural area) of 198,694 fish, based on fishing regulations and quotas. This would have exceeded the long-term management goal of 122,000 hatchery and natural area spawners in the Sacramento River basin. PFMC reported that the actual SI in 2022 was 251,191 fish, meaning that the estimated population was 37% lower than the preseason forecast, representing the largest overestimation since 2017. Given a lack of in-season management for salmon in California, this inaccurate preseason forecast led to an exploitation rate (i.e., the percentage of fish that were commercially harvested) of 75%, which was the highest exploitation rate since 2004. As a result, escapement to Central Valley rivers was severely depressed.

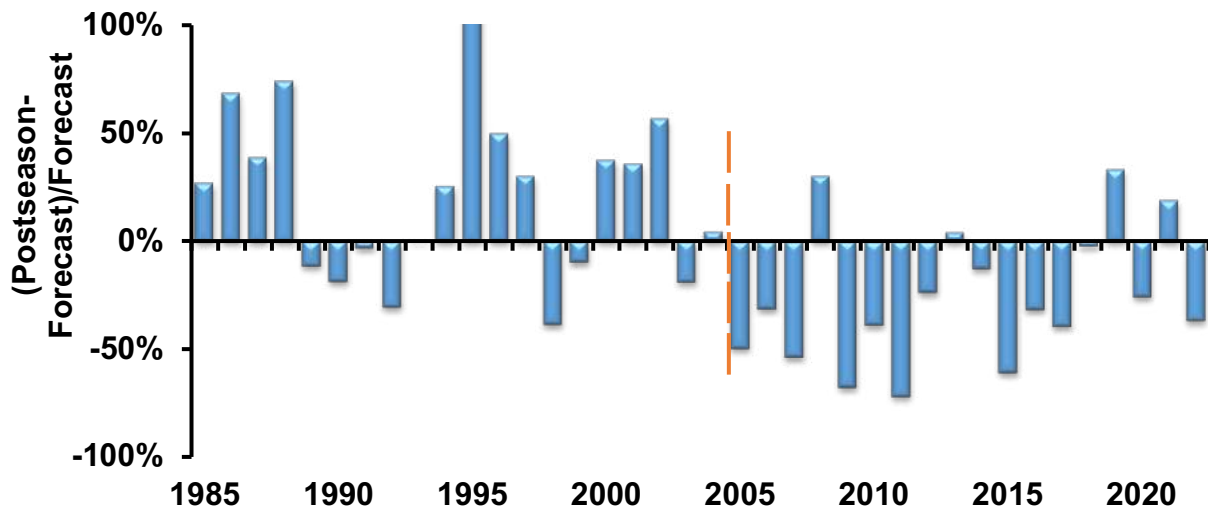

Figure 1. Percent difference from PFMC average annual preseason forecast relative to the actual SI observed, 1985-2022. Source: PFMC 2023b.

## Escapement Results of the 2022 Season

***Sacramento River Basin.*** An estimated 61,850 fall-run Chinook salmon “escaped” the harvest and spawned in hatcheries and natural areas of the Sacramento River Basin in 2022, which was far less than both the PFMFC management goal and the preseason estimate of 198,694 hatchery and natural area spawners. The 2022 escapement was 41% lower than the previous year’s total of 105,584, and 44% lower than the previous five year average the 2017 total (111,447; Figure 2). Based on the mean spawning escapement from the prior three years, the Sacramento River population met the criteria for “overfished” status each year from 2018 until 2021 (with a three-year mean population size falling below the minimum stock size threshold of 91,500 in each of the three years). Based on the current three-year mean spawning escapement (96,613), the stock is not considered overfished at this time, despite high exploitation rates during the prior year. The natural-area spawners (32,712) exceeded that of hatchery returns (29,138), which is common in most years, but is sometimes reversed in low-escapement years such as 2017. However, it is likely that hatchery-origin fish also comprise a large percentage of the natural area spawners.

***San Joaquin River Basin.*** The San Joaquin Basin has historically constituted less than 10% of the total Central Valley escapement. However, since 2015 the San Joaquin contribution has exceeded 10% every year, with an average contribution of 14%. In 2022, a total of 8,120 salmon returned to the SJR, representing exactly 14% of the total Central Valley escapement. This number of returning fish was a 40% increase over 2021 escapement, but still 25% less than the five-year average. A total of 4,538 fall-run Chinook salmon returned to natural areas of the SJR basin, and 3,582 salmon returned to Mokelumne and Merced River hatcheries combined. As in the Sacramento Basin, it is likely that hatchery-origin fish also comprise a large percentage of the natural area spawners. It is not clear why the proportion of escapement has been relatively high in the SJR basin over the past few years, but this may be due in part to decreased populations in the Sacramento Basin following the drought, as well as increased trucking and release of hatchery smolts at off-site locations resulting in increased straying of returning adults from other basins.

The Stanislaus River again received the majority of fish returning to natural areas in the San Joaquin River Basin (~70% of all natural area spawners), followed by the Mokelumne (20%), the Tuolumne (8%), the Merced (1%), and the Calaveras and Cosumnes rivers (combined total of 0%). These totals are similar to the previous few years and are reflective of historical conditions although in some years the majority of fish in the basin return to the Mokelumne River. One notable decrease in 2022 was escapement to the Merced, which decreased by 79% over the previous year, and was the lowest on record going back to the early 1980’s. Escapement to the Calaveras and Cosumnes rivers has ranged between zero and 833 over the last five years, but salmon often don’t return to those basins in drier years.



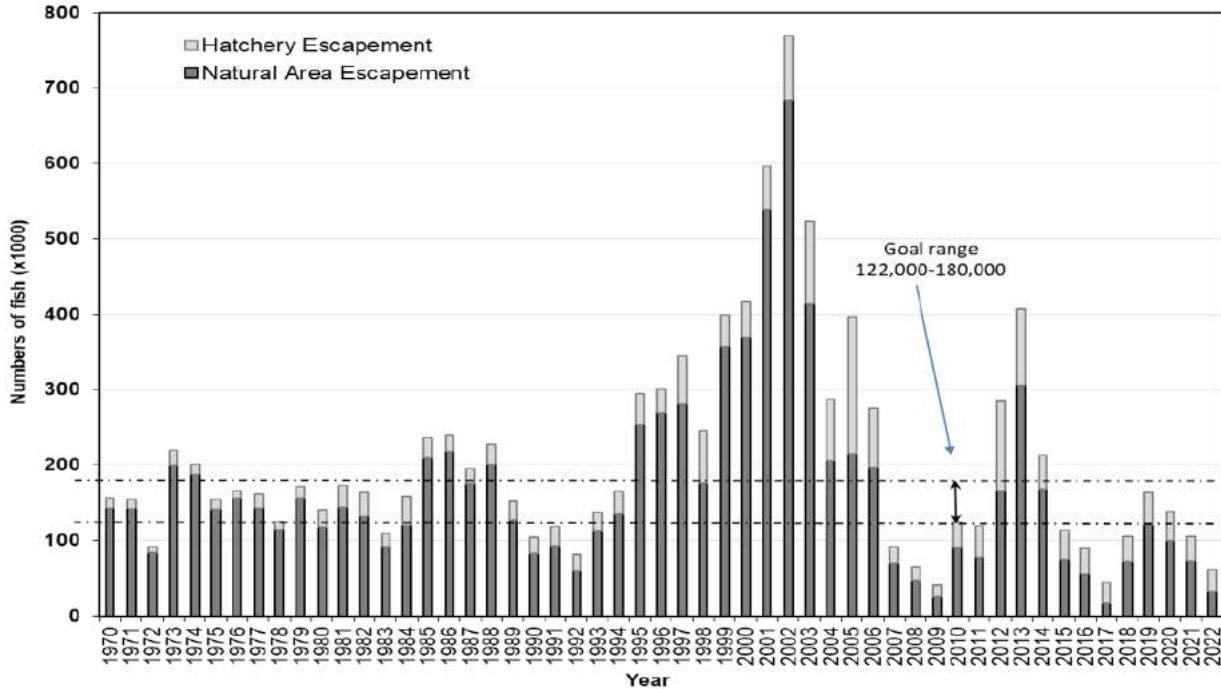

Figure 2. Sacramento River adult fall-run Chinook salmon escapement 1970-2022. Source: PFMC 2023a.

**Jack Escapement.** Accurate counts of both the number and proportion of jacks in the population (i.e., early maturing males) are important for management because they offer an indication of cohort abundance. This metric is assumed to be consistent from year to year when generating the forecasts, and changes in the proportion of jacks will alter the outputs of the forecasting models. In 2022, the proportion of the total spawning escapement in the Sacramento River and SJR basins that was made up of jacks was approximately 10% and 27%, respectively. In both basins, the proportion of jacks was less than the previous year (14% and 49%, respectively) and was much less than the previous five-year averages (21% and 40%, respectively; [Figure 3]). Despite a decrease in 2022, the proportion of jacks in the population appears to be increasing, particularly in the SJR basin (Figure 3). This increase is likely due to the cumulative impact of several factors, including reliance on hatcheries and the tendency of ocean fisheries to harvest large fish.

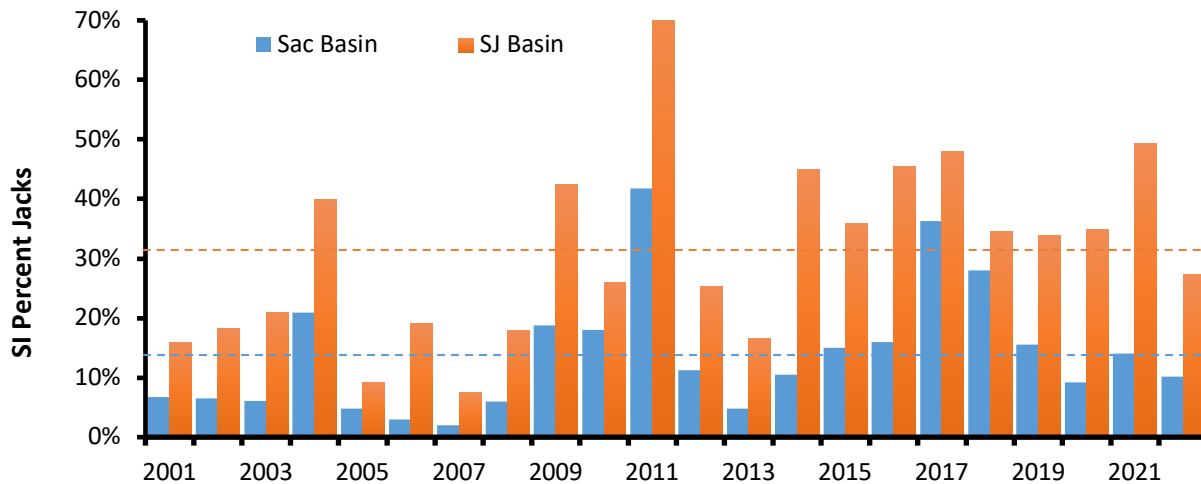
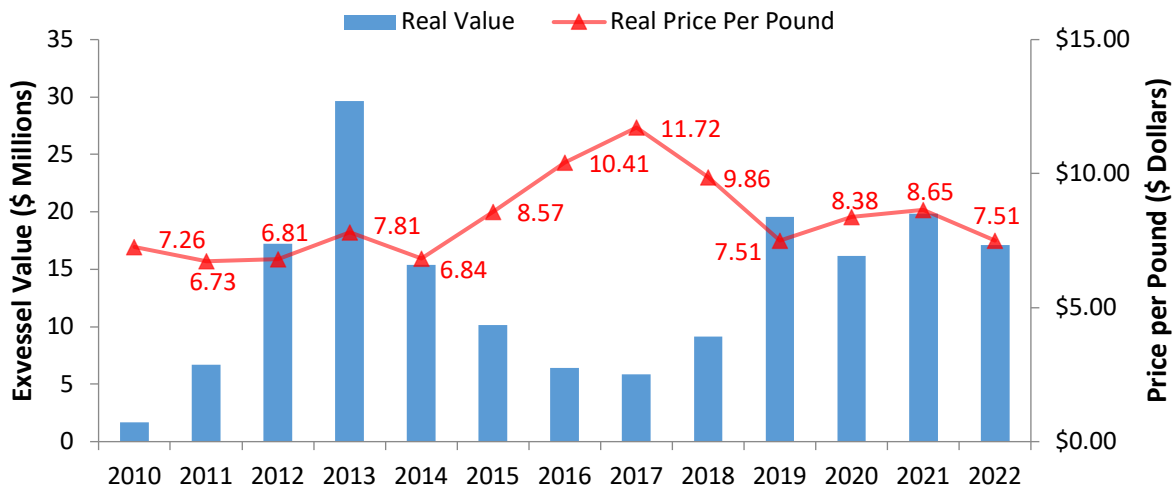

Figure 3. Fall-run Chinook jack spawning escapement as a percentage of total escapement by Basin, 2001-2022. Dotted lines represent 2001-2022 averages. Source: PFMC 2023a.

## Results of the 2022 Harvest

The commercial fishery harvest in 2022 continued to rebound from the historically low numbers of the previous few years, with landings revenues (coastwide exvessel value) of \$17.1 million. This total was 14% below the prior year’s revenue, but 21% above the 2017-2021 average of \$16.4 million (Figure 4). However, the value of the 2022 commercial salmon fishery was still 58% below the 1979-1990 inflation-adjusted average of \$40.5 million (which include coho salmon landings during that period). The total 2022 commercial catch of 211,186 fish represented a slight increase over the previous year but a 37% increase over the 2017-2021 average of 154,497 commercially caught salmon. The total catch of 2.3 million pounds was down by less than 1% from the prior year. Commercial fishing effort (boat days fished) more than doubled to 15,774 after remaining steady for three consecutive years. The average California exvessel price (i.e., price received at the dock) for troll caught Chinook salmon continued to decrease from recent highs to \$7.51 per pound, which was 13% below the prior year’s price (Figure 4).



**Figure 4. Commercial exvessel value and price per pound 2010-2022. Source: PFMC 2023a.**

On average over the last four years (2019-2022), between 79-85% of the Pacific Coast commercial Chinook landings by weight were landed in the three southern-most California port areas – Fort Bragg, San Francisco, and Monterey (Figure 5). In 2022, across the entire Pacific Coast (excluding Alaska), the highest landings shares by weight were recorded at San Francisco (53%), Monterey (18%), and Fort Bragg (8%), followed by several ports in Oregon and Washington. Prior to 2019, the average annual share landed in in the three southern-most California port areas was approximately 40%, with San Francisco producing approximately 25% of the total coastwide landings.

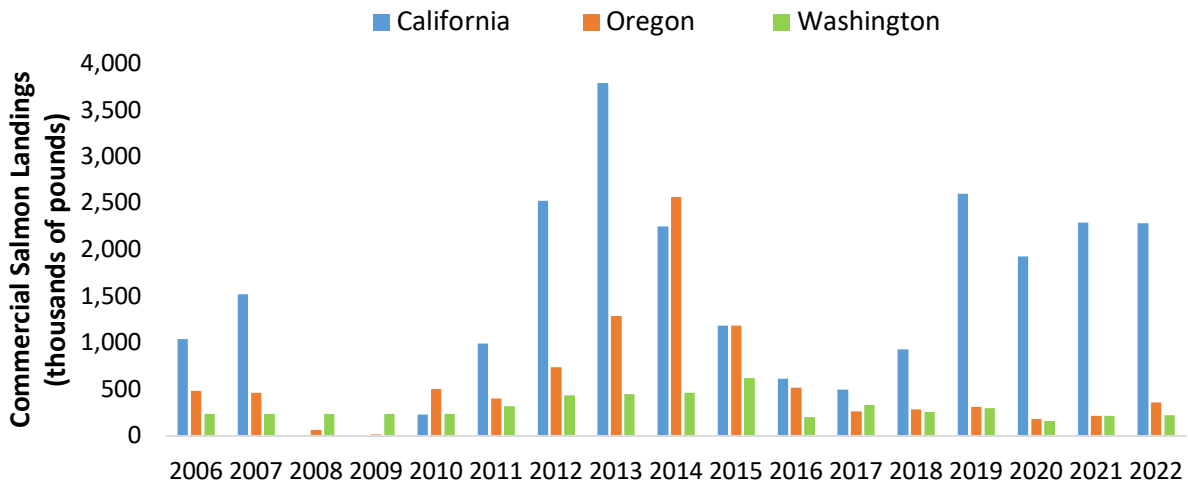

Figure 5. Pounds of salmon landed by the commercial troll ocean fishery 2006-2022. Source: PFMC 2023a.

The 2022 recreational ocean salmon catch continued the upward trend from prior years, with a total harvest of 88,961 Chinook salmon, which is the highest catch since 2013, and a 33% increase over the previous five-year average (66,732). The total of 98,504 ocean recreational salmon trips in 2022 was an 11% increase over the previous year, and a 17% increase over the average of the previous five years (84,539). This harvest continued the increasing trend of the previous couple years, perhaps due to a 50% increase in the average success rate from the previous year to 0.9 fish per angler-trip in 2022.

Recreational harvest of fall-run Chinook salmon in the Sacramento River and its tributaries totaled only 4,860 fish in 2022, after a forecasted harvest of 32,345. This inland harvest total was the lowest since 2010 and was a 55% decrease from the previous year and a 71% decrease from the average of the previous five years (16,880). In most years, the recreational catch is made up largely of hatchery fish, and it is expected that this trend continued in 2022.

### Predictions for 2023

Based on the forecast method described previously, there are an estimated 169,767 SRFC in the ocean this year. This forecast is a 57% decrease from last year’s projection (396,500) and 51% lower than the previous five-year average of 358,248. The projected SI for 2023 is also the lowest since 2009. PFMC is currently meeting to finalize harvest regulations for 2023, but as of now, all options being considered include a complete closure of the commercial and recreational fisheries. If preseason predictions are correct, California will be facing a dire situation in terms of economic and ecological impacts from a closed fishery and reduced returns to Central Valley rivers.

### References:

Pacific Fishery Management Council. 2023a. *Review of 2022 Ocean Salmon Fisheries: Stock Assessment and Fishery Evaluation Document for the Pacific Coast Salmon Fishery Management Plan*. Pacific Fishery Management Council, 7700 NE Ambassador Place, Suite 101, Portland, Oregon 97220-1384.

Pacific Fishery Management Council. 2023b. *Preseason Report I: Stock Abundance Analysis and Environmental Assessment Part 1 for 2023 Ocean Salmon Fishery Regulations*. Pacific Fishery Management Council, 7700 NE Ambassador Place, Suite 101, Portland, Oregon 97220-1384.

## SJB March Field Report

### Juvenile Migration Monitoring

The Calaveras River rotary screw trap (RST) sampled only nine days during March due to high-flow releases from New Hogan Dam. Water velocities at Shelton Road were too high to operate the 5-foot trap; however, as flows began to decrease towards the end of the month, a larger 8-foot RST was installed and began sampling approximately one mile upstream at Williams Crossing (RM 29). One Age 1+ (100-299 mm) *O. mykiss* was captured during this period, increasing the combined season total to 906 (Figure 1).

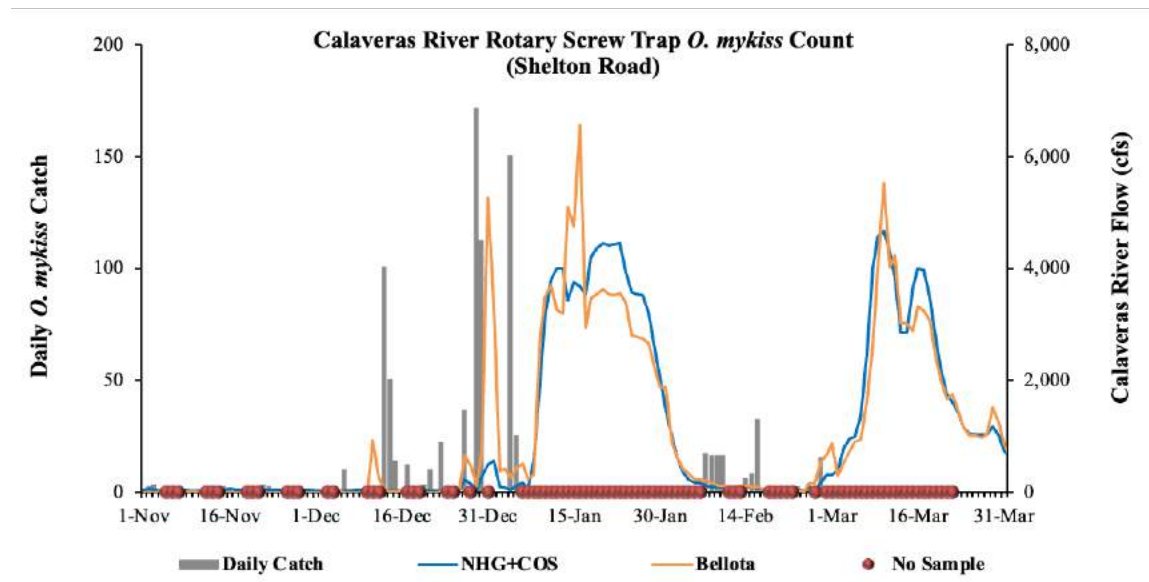

**Figure 1. Daily *O. mykiss* catch at the Calaveras River rotary screw trap at Shelton Road and Calaveras River flow at New Hogan Dam (NHG) and Bellota (MRS).**

The Stanislaus River RST at Oakdale (RM 40) sampled continuously during March, and a total of 27,774 juvenile Chinook salmon were captured increasing the season total to 53,562 (Figure 2). Daily catch ranged from 90 to 3,066 salmon during the month.

The Stanislaus River RSTs at Caswell (RM 8) operated 29 days during the month of March and captured a total of 1,716 juvenile Chinook salmon increasing the season total to 1,795 (Figure 3).



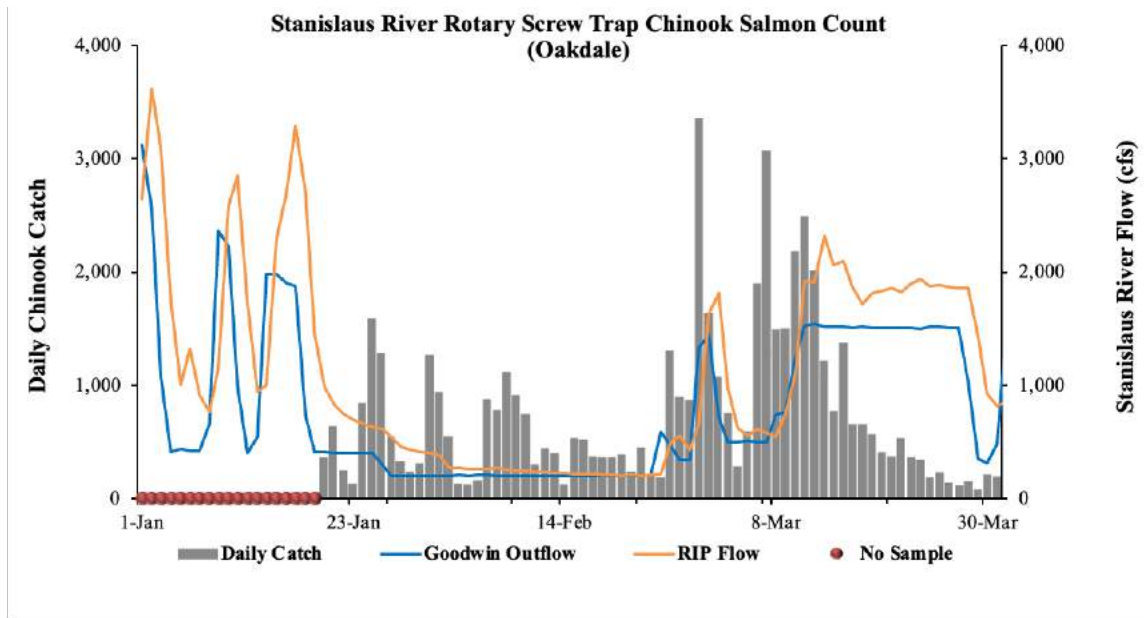

Figure 2. Daily Chinook salmon catch at the Stanislaus River rotary screw trap at Oakdale and Stanislaus River flow at Goodwin Dam (GDW) and Ripon (RIP).

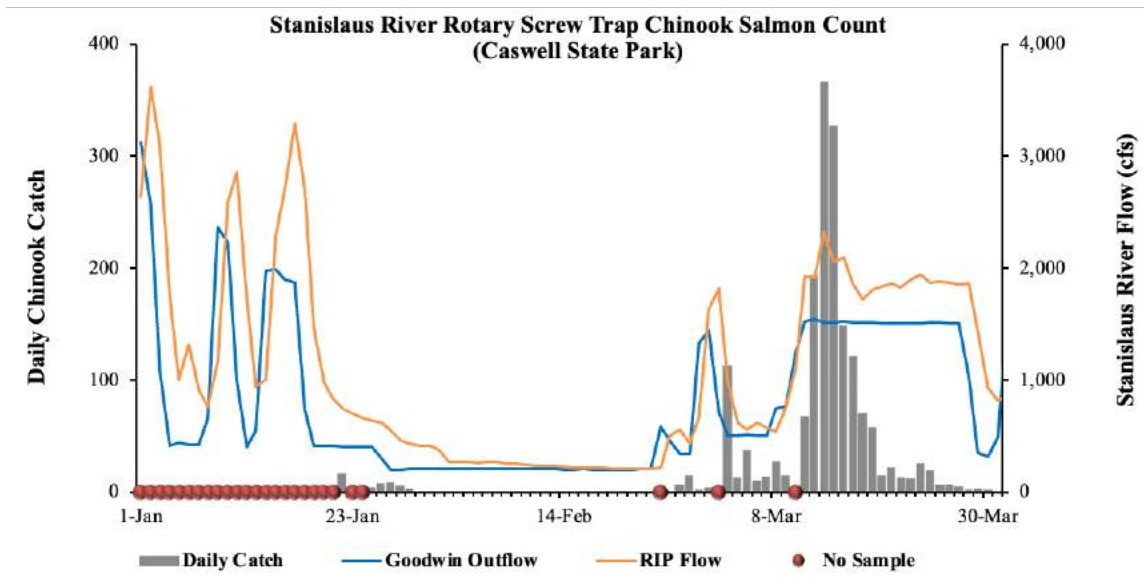

Figure 3. Daily Chinook salmon catch at the Stanislaus River rotary screw trap at Caswell and Stanislaus River flow at Goodwin Dam (GDW) and Ripon (RIP).

The Tuolumne River RST near Waterford (RM 30) operated 29 days during the month of March, and 83 Chinook salmon were captured, increasing the season total to 3,328 (Figure 4). The Tuolumne River RST near Grayson (RM 5) operated continuously through March, and 18 Chinook salmon were captured, increasing the season total to 230 (Figure 5). Releases for flood control were near 9,000 cfs at La Grange during the latter half of the month providing for challenging sampling conditions at both sites.

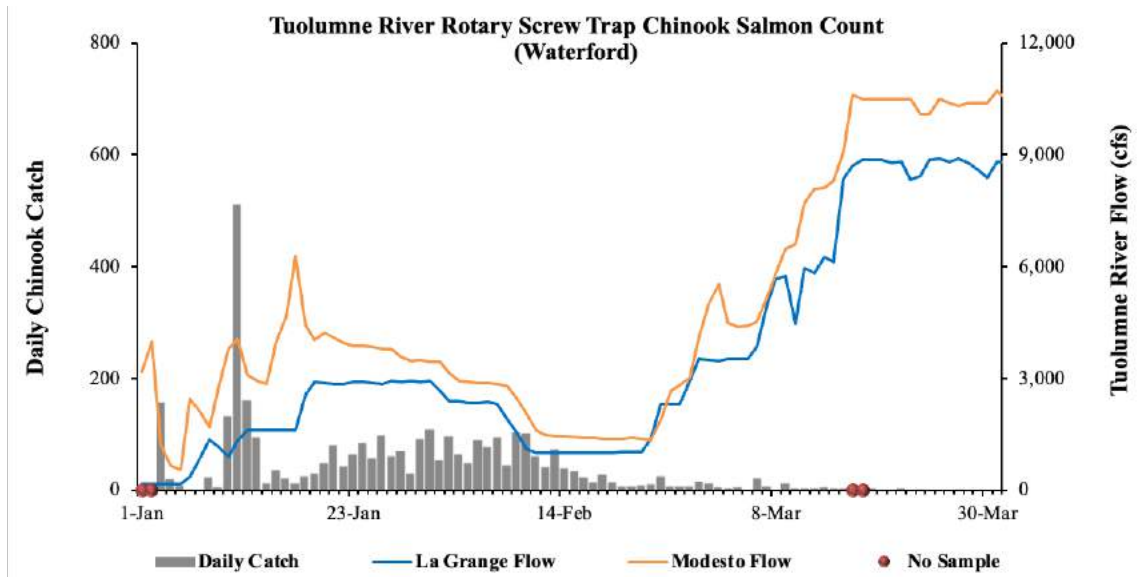

Figure 4. Daily Chinook salmon catch at the Tuolumne River rotary screw trap at Waterford and Tuolumne River flow at La Grange (LGN) and Modesto (MOD).

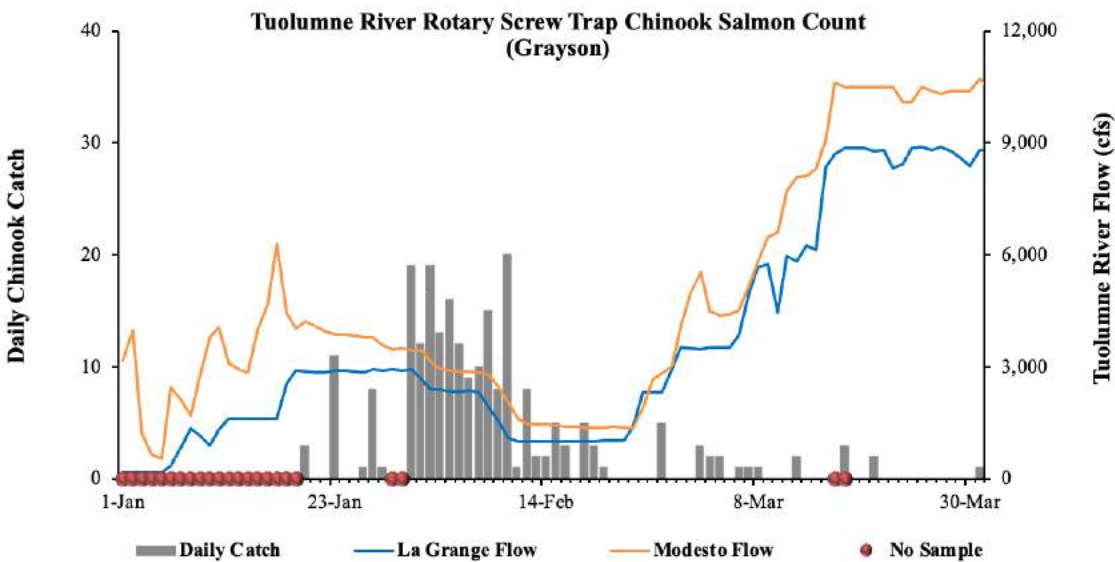

Figure 5. Daily Chinook salmon catch at the Tuolumne River rotary screw trap at Grayson and Tuolumne River flow at La Grange (LGN) and Modesto (MOD).

### Native Fish Plan

The second sampling event was conducted over eight days between March 1-9 using two catarafts. Only 31 units were sampled during the March sampling event (62 total site visits). The eight sites below Caswell to the mouth were not sampled due to weather and river flows. Average flow during the March sampling events was 688 cfs (range: 501 cfs to 1,444 cfs). A total of 355 target predatory fishes were captured. Of these, 156 were black bass (44%), 156 (44%) were native minnow

(Sacramento pikeminnow and hardhead), and six were striped bass (2%). A total of 244 predatory fish were marked with a PIT tag during March. Forty-three fish were recaptured during March sampling including 23 from tagging efforts between 2019-2022. Consistent with other sampling events and years, black bass made up the majority of the recaptures (n = 29). Diet samples were collected from 85 individual predators over the course of the sampling event. During the diet collections, we observed at least four juvenile Chinook in the samples. These are field observations alone and actual numbers detected may be slightly higher once diet samples are viewed in the lab.

The third sampling event occurred between April 3-6 using two jet boats. Data for this event is still being reviewed. The fourth 2022 sampling event will tentatively occur from May 1-4.

### **San Joaquin River Predator Study**

Twenty sites were sampled over two days using two electrofishing boats in March in the San Joaquin River, Grant Line Canal, and Old River regions of the South Delta. A total of 48 fish (5 different target species) were captured and all but two were implanted with PIT tag. Black bass (largemouth and spotted bass) ranged in size from 2.9 – 20.7 in. total length (TL), striped bass ranged in size from 11.7 – 21.0 in., and the catfish ranged in size from 10.9 – 12.4 in. Gastric lavage was performed on 38 individuals and 29 produced diet samples, which were preserved in ethanol and brought back to the laboratory for future content analysis. Only three native fishes were captured in March: three Chinook salmon and one Sacramento pikeminnow.

One largemouth bass that had been tagged during a previous survey was recaptured in March.

The San Joaquin River is currently closed from the mouth of the Stanislaus to the Stockton Deep Water Ship Channel due to extremely high flows. Electrofishing in the south Delta is temporarily on hold until water levels recede.

### **Fyke Trapping**

Between March 1 and March 7, a total of seven target fish were captured in the fyke traps (2 striped bass, 2 white catfish, 3 channel catfish). On March 8, the fykes were removed from the water due to high river flows in the San Joaquin River. The fyke traps are not permitted to be in the water when flows exceed 18,000 cfs. On March 12, flows exceeded 18,000 cfs and peaked at over 36,000 cfs on March 18. It is doubtful that the fykes will be re-installed for the remainder of the season since flows are expected to be high through summer.

**TRI-DAM**

**POWER**

**AUTHORITY**

---

**REGULAR BOARD MEETING**  
**AGENDA**  
**TRI-DAM POWER AUTHORITY**  
of THE OAKDALE IRRIGATION DISTRICT and  
THE SOUTH SAN JOAQUIN IRRIGATION DISTRICT  
**APRIL 20, 2023**  
Start time is immediately following the Tri-Dam Project meeting  
which begins at 9:00 AM

**South San Joaquin Irrigation District**  
**11011 Highway 120**  
**Manteca, CA 95336**

---

A COMPLETE COPY OF THE AGENDA PACKET WILL BE AVAILABLE ON THE OAKDALE IRRIGATION DISTRICT WEB SITE ([www.oakdaleirrigation.com](http://www.oakdaleirrigation.com)) ON MONDAY, APRIL 17, 2023 AT 9:00 A.M. ALL WRITINGS THAT ARE PUBLIC RECORDS AND RELATE TO AN AGENDA ITEM WHICH ARE DISTRIBUTED TO A MAJORITY OF THE BOARD OF DIRECTORS LESS THAN 72 HOURS PRIOR TO THE MEETING NOTICED ABOVE WILL BE MADE AVAILABLE ON THE OAKDALE IRRIGATION DISTRICT WEB SITE ([www.oakdaleirrigation.com](http://www.oakdaleirrigation.com)).

Members of the public who wish to attend and participate in the meeting remotely, as opposed to in-person, can do so via internet at <https://ssjid.zoom.us/j/98120276218> or by telephone, by calling 1 (669) 900-6833, Meeting ID: 981-2027-6218, Password: 700546. All speakers commenting on Agenda Items are limited to five (5) minutes.

Members of the public may also submit public comments in advance by e-mailing [dbarnev@ssjid.com](mailto:dbarnev@ssjid.com) by 4:30 p.m., Wednesday, April 19, 2023.

In compliance with the Americans with Disabilities Act, a person requiring an accommodation, auxiliary aid, or service to participate in this meeting should contact the Executive Assistant at (209) 249-4623, as far in advance as possible but no later than 24 hours before the scheduled event. Best efforts will be made to fulfill the request.

---

## **CALL TO ORDER**

**ROLL CALL:** John Holbrook, Dave Kamper, David Roos, Glenn Spyksma, Mike Weststeyn Brad DeBoer, Herman Doornenbal, Tom Orvis, Linda Santos, Ed Tobias

## **PUBLIC COMMENT**

---

## **CONSENT CALENDAR**

## **ITEMS 1 – 2**

Matters listed under the consent calendar are considered routine and will be acted upon under one motion. There will be no discussion of these items unless a request is made to the Board President by a Director or member of the public. Those items will be considered at the end of the consent items.

1. Approve the regular board meeting minutes of March 16, 2023.
2. Approve the March statement of obligations.

---

## **ACTION CALENDAR**

## **ITEMS 3 - 4**

3. Discussion and possible action to adopt Resolution TDPA 2023-05 Authorization for Maintenance of Deposit Accounts.
4. Discussion and possible action to move the May Board meeting date.

---

## **ADJOURNMENT**

## **ITEMS 5 - 6**

5. Commissioner Comments.
6. Adjourn to the next regularly scheduled meeting.

# BOARD AGENDA REPORT

Date: 4/20/2023  
Staff: Genna Modrell

---

**SUBJECT:** Tri-Dam Power Authority March 2023 Minutes

---

**RECOMMENDED ACTION:** Review and possible approval of March 16, 2023 Minutes

---

**BACKGROUND AND/OR HISTORY:**

Draft minutes attached.

**FISCAL IMPACT:** None

**ATTACHMENTS:** Draft minutes attached.

---

**Board Motion:**

**Motion by:** \_\_\_\_\_ **Second by:** \_\_\_\_\_

**VOTE:**

**OID:** DeBoer (Yes/No) Doornenbal (Yes/No) Orvis (Yes/No) Santos (Yes/No) Tobias (Yes/No)

**SSJID:** Holbrook (Yes/No) Kamper (Yes/No) Roos (Yes/No) Spyksma (Yes/No) Weststeyn (Yes/No)

**TRI-DAM POWER AUTHORITY  
MINUTES OF THE JOINT BOARD  
OF COMMISSIONERS REGULAR MEETING**

March 16, 2023  
Oakdale, California

The Commissioners of the Tri-Dam Power Authority met at the office of the South San Joaquin Irrigation District in Oakdale, California, on the above date for the purpose of conducting business of the Tri-Dam Power Authority, pursuant to the resolution adopted by each of the respective Districts on October 14, 1984.

President Spyksma called the meeting to order at 9:43 a.m.

**OID COMMISSIONERS**

**SSJID COMMISSIONERS**

**COMMISSIONERS PRESENT:**

ED TOBIAS  
HERMAN DOORNENBAL  
TOM ORVIS  
BRAD DeBOER  
LINDA SANTOS

JOHN HOLBROOK  
MIKE WESTSTEYN  
GLENN SPYKSMA  
DAVID ROOS

**Also Present:**

Summer Nicotero, General Manager, Tri-Dam Project; Scot A. Moody, General Manager, Oakdale Irrigation District; Peter Rietkerk, General Manager, South San Joaquin Irrigation District; Sharon Cisneros, Chief Financial Officer, Oakdale Irrigation District; Susan Larson, License Compliance Coordinator, Tri-Dam Project; Genna Modrell, Finance Asst., Tri-Dam Project; Chris Tuggle, Operations and Maintenance Manager, Tri-Dam Project; Mia Brown, Counsel, SSJID.

**PUBLIC COMMENT**

No public comment.

**CONSENT CALENDAR**

- ITEM #1** Approve the regular board meeting minutes of February 16, 2023.  
**ITEM #2** Approve the February statement of obligations.

Commissioner DeBoer moved to approve items one and two on the consent calendar. Commissioner Holbrook seconded the motion.

The motion passed by the following roll call vote:

AYES: DeBoer, Doornenbal, Orvis, Santos, Tobias, Holbrook, Roos, Spyksma, Weststeyn

NOES: None

ABSTAINING: None

ABSENT: Kamper

**ACTION ITEMS**

- ITEM #3** Review and authorize the General Manager to sign the Professional Services Agreement with Provost & Pritchard for contract administration support services for Sandbar power pole replacement and repair.



Summer Nicotero noted that this item, is similar to those for Provost & Pritchard, where contract and administrative support will be provided for the Sandbar Power Pole replacement project. Commissioner asked Chris Tuggle several questions about timing of work, number of poles to be replaced and implementation of safeguards for prevention of wildland fire. Director Spyksma recommended replacing questionable poles early.

Commissioner Santos moved to approve. Commissioner Holbrook seconded the motion.

The motion passed by the following roll call vote:

AYES: DeBoer, Doornenbal, Orvis, Santos, Tobias, Holbrook, Roos, Spyksma, Weststeyn

NOES: None

ABSTAINING: None

ABSENT: Kamper

**ITEM #4 Discussion and possible action to approve the purchase of (1) new Model 510+10ACR6 flowmeter console for Southern Powerhouse.**

Chris Tuggle advised this is the last flowmeter to upgrade completing this project.

Commissioner Santos moved to approve as presented. Commissioner Holbrook seconded the motion.

The motion passed by the following roll call vote:

AYES: DeBoer, Doornenbal, Orvis, Santos, Tobias, Holbrook, Roos, Spyksma, Weststeyn

NOES: None

ABSTAINING: None

ABSENT: Kamper

**ITEM #5 Review and possible action to approve the FERC annual land use fees for 2023.**

Summer Nicotero advised the Board this invoice is the annual fee for conducting business on government owned lands.

Commissioner Santos moved to approve as presented. Commissioner Holbrook seconded the motion.

The motion passed by the following roll call vote:

AYES: DeBoer, Doornenbal, Orvis, Santos, Tobias, Holbrook, Roos, Spyksma, Weststeyn

NOES: None

ABSTAINING: None

ABSENT: Kamper

**ITEM #6 Commissioner Comments**

None.

**ADJOURNMENT**

President Spyksma adjourned the meeting at 9:55 a.m.

The next Board of Commissioners meeting is scheduled for April 20, 2023, at the offices of San Joaquin Irrigation District immediately following the Tri-Dam Project meeting, which commences at 9:00 a.m.

ATTEST:

---

Summer Nicotero, Secretary  
Tri-Dam Project

# BOARD AGENDA REPORT

Date: 4/20/2023  
Staff: Genna Modrell

---

**SUBJECT:** Tri-Dam Power Authority March Statement of Obligations

---

**RECOMMENDED ACTION:** Recommend Approval of the March Statement of Obligations

---

**BACKGROUND AND/OR HISTORY:**

Submitted for approval is the March Statement of Obligations for Tri-Dam Power Authority.

**FISCAL IMPACT:** See Attachments

**ATTACHMENTS:** Tri-Dam Power Authority Statement of Obligations

---

**Board Motion:**

**Motion by:** \_\_\_\_\_ **Second by:** \_\_\_\_\_

**VOTE:**

**OID:** DeBoer (Yes/No) Doornenbal (Yes/No) Orvis (Yes/No) Santos (Yes/No) Tobias (Yes/No)

**SSJID:** Holbrook (Yes/No) Kamper (Yes/No) Roos (Yes/No) Spyksma (Yes/No) Weststeyn (Yes/No)

# Tri-Dam Power Authority

## Statement of Obligations

March 1, 2023 to March 31, 2023

**TRI-DAM POWER AUTHORITY  
STATEMENT OF OBLIGATIONS**

**Period Covered  
March 1, 2023 to March 31, 2023**

**Total Obligations:** **4** **checks** **in the amount of** **\$10,710.77**  
(See attached Vendor Check Register Report)

**CERTIFICATION**

**OAKDALE IRRIGATION DISTRICT**

**SOUTH SAN JOAQUIN IRRIGATION DISTRICT**

\_\_\_\_\_  
Thomas D. Orvis

\_\_\_\_\_  
John Holbrook

\_\_\_\_\_  
Ed Tobias

\_\_\_\_\_  
Dave Kamper

\_\_\_\_\_  
Linda Santos

\_\_\_\_\_  
David Roos

\_\_\_\_\_  
Herman Doornenbal

\_\_\_\_\_  
Glenn Spyksma

\_\_\_\_\_  
Brad DeBoer

\_\_\_\_\_  
Mike Weststeyn

To: Peter Rietkerk, SSJID General Manager:

THE UNDERSIGNED, EACH FOR HIMSELF, CERTIFIES THAT HE IS PRESIDENT OR SECRETARY OF THE TRI-DAM POWER AUTHORITY; THAT THE AMOUNTS DESIGNATED ABOVE HAVE BEEN ACTUALLY, AND NECESSARILY AND PROPERLY EXPENDED OR INCURRED AS AN OBLIGATION OF THE TRI-DAM POWER AUTHORITY FOR WORK PERFORMED OR MATERIALS FURNISHED FOR OPERATIONS AND MAINTENANCE OF THE SAND BAR PROJECT; THAT WARRANTS FOR PAYMENT OF SAID AMOUNTS HAVE BEEN DRAWN ON THE SAND BAR PROJECT O & M CHECKING ACCOUNT AT OAK VALLEY COMMUNITY BANK, SONORA, CALIFORNIA.

TRI-DAM POWER AUTHORITY  
PRESIDENT,

TRI-DAM POWER AUTHORITY  
SECRETARY,

\_\_\_\_\_  
Glenn Spyksma, President      Date

\_\_\_\_\_  
Summer Nicotero, Secretary      Date

# Authority

## March Checks



Check	Vendor No	Vendor	Date	Description	Amount
208334	10500	OID ~ Routine	03/06/2023		979.34
208335	11440	JLK Enterprises	03/14/2023		679.47
208336	11343	Tim O'Laughlin	03/14/2023	Legal Matters	9,015.00
208337	11435	VISA	03/27/2023		36.96
Report Total:					\$ 10,710.77

# BOARD AGENDA REPORT

Date: April 20, 2023  
Staff: Summer Nicotero

---

**SUBJECT: REVIEW AND TAKE POSSIBLE ACTION TO ADOPT A RESOLUTION FOR DESIGNATION OF BANK ACCOUNT SIGNATORIES FOR THE TRI-DAM POWER AUTHORITY**

---

**RECOMMENDED ACTION:** Approve Adoption of the Resolution for Designation of Bank Account Signatories for the Tri-Dam Power Authority on the Oak Valley Community Bank

---

**BACKGROUND AND/OR HISTORY:**

The attached resolution is submitted for authorization of a new signatories and reaffirming prior signatories for the Oak Valley Community Bank accounts held by the Tri-Dam Power Authority.

The attached adds Vera Whittenburg, Finance Manager, Tri-Dam Project.

**FISCAL IMPACT:** None

**ATTACHMENTS:** Resolution TDPA 2023-05, Designation of Bank Accounts and Signatories

---

**Board Motion:**

**Motion by:** \_\_\_\_\_ **Second by:** \_\_\_\_\_

**VOTE:**

**OID:** DeBoer (Yes/No) Doornenbal (Yes/No) Orvis (Yes/No) Santos (Yes/No) Tobias (Yes/No)

**SSJID:** Holbrook (Yes/No) Kamper (Yes/No) Roos (Yes/No) Spyksma (Yes/No) Weststeyn (Yes/No)

**TRI-DAM POWER AUTHORITY  
Oakdale Irrigation District  
South San Joaquin Irrigation District**

**RESOLUTION NO. TDPA 2023-05**

**DESIGNATION OF BANK ACCOUNTS AND SIGNATORIES**

**WHEREAS**, the Joint Board of Directors of said Tri-Dam Power Authority desires that specific persons be authorized to deposit funds in and withdraw funds from said accounts, with the full power to endorse and sign documents required to accomplish such purposes.

**NOW THEREFORE, BE IT RESOLVED**, that the specific accounts referred to and the persons designated to sign on each of said accounts together with their respective official titles, are as follows:

**BANK:**           Oak Valley Community Bank (All accounts)  
                          US Bank

**CHECK SIGNATORIES:**

Peter M. Rietkerk, General Manager, South San Joaquin Irrigation District  
Scot A. Moody, General Manager, Oakdale Irrigation District  
Sharon Cisneros, Chief Financial Officer, Oakdale Irrigation District  
Sonya Williams, Finance and Administration Manager, South San Joaquin Irrigation District  
Summer Nicotero, General Manager, Tri-Dam Project  
Vera Whittenburg, Finance Manager, Tri-Dam Project

**BE IT FURTHER RESOLVED**, that two signatures from the “**CHECK SIGNATORIES**” listed above are required on checks.

**PASSED AND ADOPTED**, this 20th day of April 2023 by the following vote.

**OAKDALE IRRIGATION DISTRICT**

**SOUTH SAN JOAQUIN IRRIGATION DISTRICT**

**AYES:  
NOES:  
ABSTAIN:  
ABSENT:**

**OAKDALE IRRIGATION DISTRICT**

**SOUTH SAN JOAQUIN IRRIGATION DISTRICT**

\_\_\_\_\_  
Tom D. Orvis, President

\_\_\_\_\_  
Mike Weststeyn, President

\_\_\_\_\_  
Scot A. Moody, Secretary

\_\_\_\_\_  
Peter M. Rietkerk, Secretary

# BOARD AGENDA REPORT

Date: 4/20/23  
Staff: Summer Nicotero

---

**SUBJECT:** May Board Meeting

---

**RECOMMENDED ACTION:** Cancel the Regular May Meeting and Schedule a Special Meeting for Wednesday, May 17

---

**BACKGROUND AND/OR HISTORY:**

Our regularly scheduled May board meeting is set for Thursday, May 18. Due to several staff conflicts, Tri-Dam staff request that the Board consider canceling this meeting and scheduling a Special Meeting. Staff have proposed Wednesday, May 17<sup>th</sup> at the regular meeting time as a Special Meeting recommendation.

**FISCAL IMPACT:** None

**ATTACHMENTS:** None

---

**Board Motion:**

**Motion by:** \_\_\_\_\_ **Second by:** \_\_\_\_\_

**VOTE:**

**OID:** DeBoer (Yes/No) Doornenbal (Yes/No) Orvis (Yes/No) Santos (Yes/No) Tobias (Yes/No)

**SSJID:** Holbrook (Yes/No) Kamper (Yes/No) Roos (Yes/No) Spyksma (Yes/No) Weststeyn (Yes/No)